

TEST EDITION

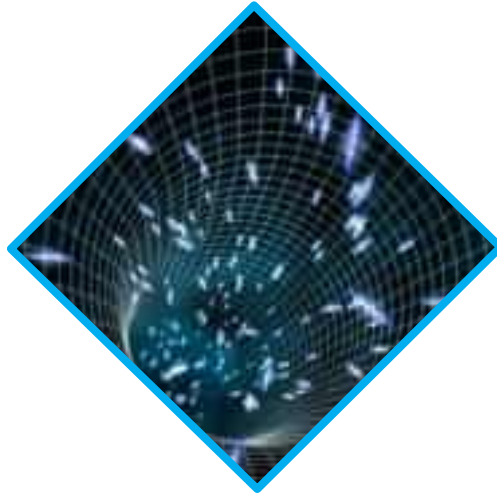

THE TEXTBOOK OF
PHYSICS

For Class - **XI**



Sindh Textbook Board

Published by:
Universal Book Depot, Hyderabad.

All rights are reserved with the **SINDH TEXTBOOK, BOARD, JAMSHORO.**
Prepared by **SINDH TEXTBOOK, BOARD, JAMSHORO.**
Reviewed by **Directorate of Curriculum Assessment and Research Sindh, Jamshoro**
Prescribed by the Board of Intermediate and Secondary Education Hyderabad, Sukkur,
Shaheed Benazirabad, Larkana, Mirpurkhas and Karachi for Secondary School Examination.
Approved by the **Education and Literacy Department, Government of Sindh.**
No. SELD/HCW/18/2018 Dated 10th, August 2023.

Patron in Chief
Pervaiz Ahmed Baloch
Chairman, Sindh Textbook Board.

Abdul Rehman Indher
(Asst: Subject Specialist)

AUTHORS

- ★ Dr. Mazhar Ali Abbasi
- ★ Dr. Syed Naseem Hussain Shah
- ★ Assoc Prof: Atta Hussain Lakho
- ★ Assoc Prof: Tariq Salahuddin
- ★ Assoc Prof: Syed Rehan Ali

INTERNAL REVIEWERS

- ★ Dr. Imran Ali Halepoto
- ★ Prof: Mian Saeed Ahmed Indher
- ★ Lecturer Mian Ayaz Ahmed Indher
- ★ Lecturer Khalid Ahmed Abbasi

CO-ORDINATOR

- ★ Muhammad Ayoub Junejo

REVIEWERS

- ★ Dr. Mazhar Ali Abbasi
- ★ Dr. Abdul Qadir Rahimoon
- ★ Dr. Barkat Ali Laghari
- ★ Mr. Noor Ahmed Khoso
- ★ Ms. Rozina Channar
- ★ Mr. Sarwaruddin Jamali
- ★ Mr. Zaheer Ahmed Abbasi
- ★ Mr. Kashif Mubeen

EDITORS

- ★ Dr. Abdul Qadir Rahimoon
- ★ Dr. Mazhar Ali Abbasi

Designing and Layout

- ★ Mr. Muhammad Arslan Shafaat Gaddi

Printed at: Paramount Printing Press, Karachi

CONTENTS

Unit No.	Unit Name	Weightage	Page No.
01	Measurements	11%	01 - 29
02	Kinematics	5%	30 - 56
03	Dynamics	6%	57 - 72
04	Rotational and Circular Motion	8%	73 - 97
05	Work, Energy and Power	10%	98 - 121
06	Fluid Statics	4%	122 - 140
07	Fluid Dynamics	6%	141 - 160
08	Electric Fields	11%	161 - 182
09	Capacitors	3%	183 - 196
10	D.C Circuits	10%	197 - 223
11	Oscillations	7%	224 - 247
12	Acoustics	8%	248 - 274
13	Physical Optics	8%	275 - 304
14	Communication	4%	305 - 321

PREFACE

The century we have stepped in, is the century of Science and technology. The modern disciplines of Physics are strongly influencing not only all the branches of science but each and every aspect of human life.

To keep the students abreast with the recent knowledge; it is must that the curricula at all the levels be updated. Moreover regularly by introducing the rapid and multidirectional development taking place in all the branches of Physics.

The recent book of Physics for Class -XI has been written in this preview and in accordance with the revised curriculum. Prepared by Ministry of Education, Govt of Sindh. Reviewed by independent team of Directorate of Curriculum Assessment and Research, Jamshoro Sindh. Keeping in view the importance of Physics, the topics have been revised and re-written according to the need of the time.

Among the new editions the introductory paragraphs, information boxes, summaries and a variety of extensive exercises have been included. Which I think will not only develop the interest but also add a lot to the utility of the book.

The Sind Textbook Board has taken great pains and incurred expenditure in publishing this book inspite to its limitations. A textbook is indeed not the last word and there is always room for improvement. While the authors have tried their level best to make the most suitable presentation, both in terms of concept and treatment. There may still have some deficiencies and omissions. Learned teachers and worthy students are therefore requested to be kind enough to point out the short comings of the text or diagrams and to communicate their suggestions and objections for the improvement of the next edition of this book.

In the end, I am thankful to our Authors, Editors and Subject specialist of Board for their relentless service rendered for the cause of education.

Chairman
Sindh Textbook Board

Unit

1

Physics and Measurements

Teaching Periods 17

Weightage % 11



Pride of Pakistan, World's second highest peak, K-2, summit of 8611 meters.

In this unit student should be able to:

- Describe Physics.
- Describe the scope of Physics in science, technology and society.
- State SI base units, derive units and supplementary units for various measurements.
- Express derived units as products or quotients of the base units.
- State the conventions for indicating units as set in the SI units.
- Measure, using appropriate techniques, the length, mass, time temperature and electrical quantities by making use of both analogue scales and digital displays particularly, short time interval by ticker timer and by C.R.O.
- Check the homogeneity of physical equations by using dimensionality and base units.
- Derive formulae in simple cases using dimensions.
- Why all measurements contain some uncertainty.
- Distinguish between systematic errors (including zero errors) and random errors.
- Measure the diameters of few ball bearings of different sizes and estimate their volumes mention the uncertainty in each result.
- Analyze and evaluate the above experiment and suggest improvements.
- Assess the uncertainty in a derived quantity by simple addition of actual, fractional or percentage uncertainties.
- Identify dependent and independent variables.
- Draw line of best fit and error bar
- Draw extrapolation.
- Write answers with correct scientific notation, number of significant figures and units in all numerical and practical work.
- Identify that least count or resolution of a measuring instrument is the smallest increment measurable by it.
- Differentiate between precision and accuracy.
- Explain why it is important to use and instrument of smallest resolution.
- Explain the importance of increasing the number of readings in an experiment.
- Interpret the information from linear or nonlinear graphs / curves by measuring slopes and intercepts.

Measurements in physics play a crucial role in understanding and quantifying physical phenomena. They involve the determination of various properties such as length, mass, time, temperature and energy. Precise and accurate measurements provide the foundation for scientific investigations and the development of theories and models.

**DO YOU
KNOW?**

Migrating birds use celestial cues and magnetic field generated by Earth's molten core to reach their destination



1.1 Scope of Physics:

What do fly birds, moving automobiles, looking blue sky and vibrating cellular phones have in common? They all follow physics or physical laws.

Birds use the difference in air pressures above and below their wings to keep them aloft. Automobiles follow the principles of mechanics and thermodynamics to transfer stored gasoline for moving tires. The sky seems blue when sunlight strikes and scatters off nitrogen and oxygen molecules in the atmosphere. Lastly, cellular phones use electronic components and the principles of electromagnetic waves to transfer energy and information from one to another phone.

1.1.1 Physics:

Physics is a branch of science that seeks to understand and describe the fundamental principles and laws governing the natural world. It encompasses the study of matter, energy, space, and time, and how they interact with each other.

The goal of physics is to develop a set of mathematical models and theories that can explain and predict the behavior of physical systems. These models are based on observations, experiments, and measurements, and are refined through a process of hypothesis testing and verification.

Physics is often divided into several sub-disciplines, each focusing on different aspects of the physical world:

Classical Mechanics: This branch deals with the motion of objects and the forces that act upon them. It includes concepts such as Newton's laws of motion, kinematics, momentum, and energy.

Electromagnetism: Electromagnetic theory explains the behavior of electric and magnetic fields, as well as their interaction with charged particles and currents. It encompasses topics like electric and magnetic forces, electromagnetic waves, and the principles underlying electricity and magnetism.

Unit 1: Physics and Measurements

Thermodynamics: Thermodynamics deals with the study of heat, energy, and their transformations. It explores concepts like temperature, entropy, energy conservation, and the behavior of gases and fluids.

Optics: Optics focuses on the properties and behavior of light. It covers topics such as reflection, refraction, diffraction, and the interaction of light with various materials and optical systems.

Quantum Mechanics: Quantum mechanics is the branch of physics that deals with the behavior of particles at the atomic and subatomic levels. It describes phenomena that classical mechanics cannot explain, such as wave-particle duality, quantum superposition, and quantum entanglement.

Relativity: Relativity theory, including both special relativity and general relativity, deals with the behavior of objects in extreme conditions, such as those involving high speed or strong gravitational field. It explores concepts like mass variation, time dilation, length contraction, and the curvature of space-time.

These are just a few examples of the many subfields within physics. Physics plays a crucial role in understanding the fundamental nature of the universe, from the microscopic world of particles to the vast scales of galaxies and the cosmos. It also underlies many technological advancements and has practical applications in various industries, including engineering, medicine, and telecommunications.

1.1.2 Scope of Physics Science, Technology and Society:

Physics plays a significant role in science, technology and society across various domains. Here are some key aspects highlighting the scope of physics in these areas:

Science:

Fundamental Laws: Physics provides fundamental laws and principles that form the basis of understanding the natural world. It explores the behavior of matter, energy, forces and their interactions, enabling scientists to develop theories and models to explain phenomena.

Advancing Knowledge: Physics drives scientific progress by pushing the boundaries of our understanding. It seeks to uncover new insights into the nature of the universe, from the microscopic realm of particles to the vast expanse of the cosmos.

Interdisciplinary Connections: Physics often intersects with other scientific disciplines, such as chemistry, biology, astronomy, and geology. It provides a framework for understanding complex systems and phenomena, facilitating interdisciplinary research and collaboration.

Technology:

Engineering Applications: Physics principles are employed in various engineering fields. For example, electrical engineers rely on electromagnetism, materials engineers utilize quantum mechanics, and mechanical engineers apply laws of motion to design and optimize technologies.

Energy and Power: Physics plays a crucial role in the generation, transmission, and utilization of energy. It underpins technologies such as renewable energy systems, nuclear power, electrical grids, and energy storage.

Electronics and Communications: Physics principles are fundamental to the development of electronic devices, telecommunications and information technology. The study of semiconductor physics, quantum mechanics and electromagnetism is essential for advancing these fields.

Society:

Medical Applications: Physics contributes to medical imaging technologies like X-rays, CT scans, MRI, and ultrasound. It also facilitates advancements in radiation therapy, laser surgery, and medical diagnostics.

Materials Science: Physics research aids in understanding the properties of materials and developing new materials for various applications, including electronics, transportation, construction, and energy technologies.

Environmental Studies: Physics plays a role in studying climate change, atmospheric and environmental monitoring. It helps in developing sustainable technologies and understanding the impact of human activities on the planet.

Education and Scientific Literacy: Physics education fosters critical thinking, problem-solving skills, and a scientific mindset. It promotes scientific literacy, enabling individuals to make informed decisions and engage with science-related topics and issues.

Overall, physics provides the foundation for scientific advancements, technological innovations, and a deeper understanding of the world. Its scope extends across diverse fields, contributing to the progress of science, technology, and society as a whole.

1.2 SI Base, Derived Units and Supplementary Units

Units are standards of measurement that are used to express physical quantities such as length, mass, time, temperature, electric current, and many others. Units provide a way to quantify and compare the magnitude of physical quantities and to communicate these measurements in a clear and concise manner.

Unit 1: Physics and Measurements

There are various systems of units, including the International System of Units (SI), which is the most widely used system in the world. Other systems of units, such as the British system or the U.S. customary system, are also used in certain regions or industries.

1.2.1 SI Base Units:

(SI units also known as the International System of Units, are a system of units used for measurement that has been officially adopted by the International System of Units (SI). This system is used for scientific, engineering, and technological applications, and it provides a consistent and standardized way of measuring physical quantities.)

Table 1.1 SI Base Quantities and Units

Quantity	Unit	Unit Abbreviation
Length	meter	m
Time	second	s
Mass	kilogram	kg
Electric Current	ampere	A
Thermodynamic Temperature	kelvin	K
Amount of Substance	mole	mol
Luminous Intensity	candela	cd

SI Derived Units:

(Derived units, in the context of measurement, are units of measure that are defined **based on combinations of base units**. In the International System of Units (SI), there are many derived units that are used to express different physical quantities.)

Derived units are those which are obtained by the multiplication or division of base units. For example, the SI unit of force is the derived unit newton (N): One newton is equal to 1 kg m/s^2 .

Table 1.2: Units derived through base quantities and formula are derived units.

Physical Quantity	Derived Unit	Symbol
Volume	liter/cubic meter	l/m^3
Area	square meter	m^2
Force	newton	N
Speed / Velocity	meter per second	m/s

Supplementary Units:

Supplementary units, in the context of measurement, are units of measure that are not part of the base units in the International System of Units (SI) but are used to express certain physical quantities that are not directly covered by the base units.

Supplementary units are the dimensionless units that are used along with the base units in the SI units. Supplementary quantities are geometrical quantities of circle and sphere.

Table 1.3: Supplementary Units

Physical Quantities	Supplementary unit	Symbol	Definition
Plane Angle	Radian	rad	A unit of measurement of angles equal to 57.3° , equivalent to the angle subtended at the center of a circle by an arc equal in length to the radius as shown in figure 1.1 (a).
Solid Angle	Steradian	Sr	The solid angle subtended at the center of a sphere by an area of its surface equal to the square of the radius of that sphere as shown in figure 1.1 (b).

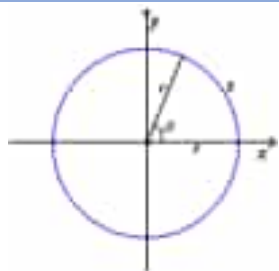

Radian

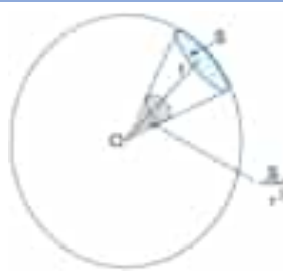

Steradian

Fig. 1.1 (a) and (b)

1.2.2 Derived Units as Products or Derived units as quotients of the base units.

A derived quantity is defined based on a combination of base quantities and has a derived unit that is the exponent, product or quotient of these base units. Some examples are given in table 1.4

Table 1.4: Derived units

Derived Quantity	Unit	Symbol	Product / Quotient	SI Base Units
Pressure	Pascal	Pa	N / m^2	$\text{kg m}^{-1} \text{s}^{-2}$
Energy / Work	Joule	J	$\text{N} \cdot \text{m}$	$\text{kg m}^2 \text{s}^{-2}$
Power	Watt	W	J / s	$\text{kg m}^2 \text{s}^{-3}$
Electric Resistance	Ohm	Ω	V / A	$\text{kg m}^2 \text{s}^{-3} \text{A}^{-2}$
Capacitance	Farad	F	C / V	$\text{kg}^{-1} \text{m}^{-2} \text{s}^4 \text{A}^2$

1.2.3 Conventions for Units:

Conventions for units in physics follow established standards to ensure consistent and standardized communication of measurements. Here are some key conventions for units in physics:

International System of Units (SI): The SI system is the globally accepted standard for units of measurement in physics. It provides a coherent set of base units and derived units that cover various physical quantities. The SI units are used to express measurements consistently and facilitate scientific communication.

Base Units: The SI system defines seven base units, which are used to express fundamental physical quantities.

Prefixes: The SI system incorporates a range of prefixes that can be used with base units to represent multiples or fractions of those units. These prefixes make it easier to express measurements across a wide range of magnitudes. Some common SI prefixes include kilo (k), mega (M), milli (m), micro (μ), and nano (n).

Consistent Formatting: When writing units, it is important to adhere to consistent formatting conventions. Units should be written in lowercase letters, except for symbols derived from names of scientists, such as the Kelvin unit (K). It is also standard practice to write units in singular form, except when quantities are greater than one (e.g., 10 meters).

Appropriate choice of units: It is important to use units that are appropriate for the quantity being measured. Using the correct units helps to avoid confusion and ensures accurate representation of physical quantities. For example, using meters per second (m/s) for speed and meters per second squared (m/s^2) for acceleration.

1.2.4 Measurement Techniques:

To measure different physical quantities, various techniques and instruments are used. Here are some common measurement techniques for length, mass, time, temperature, and electrical quantities:

Length:

The length of an object can be measured using a ruler, caliper, or tape measure.

Moreover, there are certain digital methods to measure the length such as laser rangefinders, digital sliding clipper, odometer, etc

Mass:

Physical Balance: A balance or weighing scale can be used to directly measure the mass of an object. In some cases, mass can be inferred from measurements such as weight (force due to gravity) using the appropriate conversion factors.

Time:

Mechanical clocks: This is a traditional method that uses a mechanism, such as a swinging pendulum or a rotating escapement, to keep time. Examples include grandfather clocks, cuckoo clocks, and wristwatches.

Atomic Clock: For highly accurate and precise time measurements, atomic clocks, such as cesium or rubidium atomic clocks, are used.

Measurement of Speed by the ticker timer:

The ticker timer is simply a piece of apparatus that we use to measure time. When you work out the speed of an object you need to know how far it goes in a certain time.

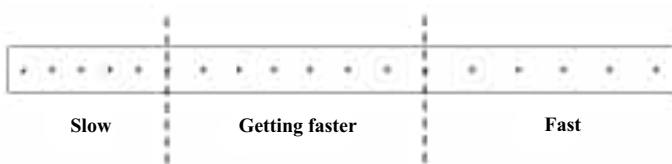

Fig: 1.2 Measurement of speed

DO YOU KNOW?

Solar daytime, or simply "daytime," refers to the period of the day when the Sun is visible in the sky. It is the time between sunrise and sunset.

DO YOU KNOW?

Foot, pace, and yard are some other units of lengths based on body parts. However, these units are not reliable as the length of body parts varies from person to person. Therefore, people realized the need for Standard Units of Measurement

DO YOU KNOW?

Ancient Time Measurement Devices

In ancient times sundials, sandglass and pendulum were used to measure time each of them is shown in figure below.



Sundial



Sandglass



Pendulum

Activity: Make a water clock by using two water bottles with some color liquid. You are going to create ancient time piece.

Temperature:

Thermometer: A thermometer can be used to measure temperature. Various types of thermometers, such as liquid-in-glass thermometers, digital thermometers, or infrared thermometers, are available for different temperature ranges and applications (Fig: 1.3 A)

Thermocouple: Thermocouples are temperature sensors that utilize the temperature-dependent voltage across the junction of two dissimilar metals. (Fig: 1.3 B)

Measuring Instruments for electrical quantities:

Voltmeter: Voltage can be measured using a voltmeter, which is connected in parallel to the circuit or component being measured.

Ammeter: Current can be measured using an ammeter, which is connected in series with the circuit or component being measured.

Ohm meter: Resistance can be measured using an ohmmeter or a multimeter, which measures the electrical resistance of a component or circuit (Fig: 1.3 B)

Cathode Ray Oscilloscope (C.R.O):

A cathode ray oscilloscope (CRO) is a type of electronic instrument that can be used for a variety of measurement techniques as shown in figure 1.4. Some common techniques that can be performed with a CRO include:

Voltage measurement: A CRO can be used to measure the voltage of a signal by displaying its waveform on the screen. The vertical axis of the display represents the voltage and the horizontal axis represents time. The peak-to-peak voltage of the signal can be measured by using the CRO's vertical and horizontal cursors.

1.3 Dimensionality:

The nature of a physical quantity is known as dimension.

The dimensions of length, mass and time is denoted by [L], [M] and [T] respectively. Also, for electric current [A] and thermodynamic temperature is [K]. As derived quantities are products or quotients which means formula may differ but their dimensionality is equalized.

The dimensions of a physical quantity are the power to which the units of the base quantity are raised to represent a derived unit of that quantity.

$$Velocity = \frac{Displacement}{time} = \frac{[L]}{[T]} = [M^0 L T^{-1}]$$

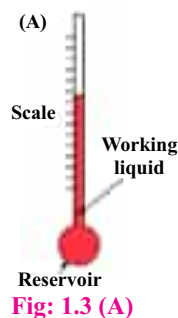

Fig: 1.3 (A)

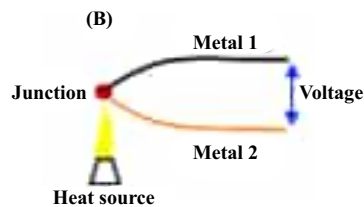

Fig: 1.3 (B)

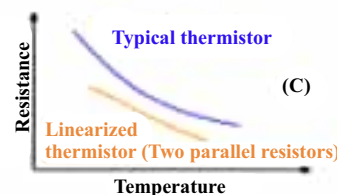

Fig: 1.3 (C)



Fig: 1.4 (CRO)

Here the dimension of velocity is zero in mass, one in length and negative one in time. Some dimensions of physical quantities are given as under in table 1.5.

Table 1.5: Dimensional formula for various physical quantities

Physical Quantities	Expression	Dimensional Formula
Area	Length \times Breadth	$[L^2]$
Density	Mass/ volume	$[ML^{-3}]$
Momentum	Mass \times velocity	$[MLT^{-1}]$
Work / Energy	Force \times displacement	$[ML^2T^{-2}]$
Electric Charge	Current \times time	$[AT]$
Gravitational Constant	$[\text{Force} \times (\text{distance})^2] / \text{mass}^2$	$[M^{-1}L^3T^{-2}]$
Moment of Inertia	Mass \times (distance) ²	$[ML^2]$
Moment of force	Force \times distance	$[ML^2T^{-2}]$
Angular Momentum	Linear Momentum \times distance	$[ML^2T^{-1}]$

DO YOU KNOW?

Applications of Dimensionality:

Dimensionality is a fundamental aspect of measurement and is applied in real-life physics. We make use of dimensional analysis for three prominent reasons:

- To check the consistency of a dimensional equation
- To derive the relation between physical quantities in physical phenomena
- To change units from one system to another

Limitations of Dimensionality:

Some limitations of dimensionality are:

- It doesn't give information about the dimensional constant.
- The formula containing trigonometric function, exponential functions, logarithmic function, etc. cannot be derived.
- It gives no information about whether a physical quantity is a scalar or vector.

1.3.1 Homogeneity of Physical Equation by Dimensionality:

Dimensionality or dimensional analysis is a technique used in physics to check the consistency of equations and measurements. It involves analyzing the dimensions of each term in an equation to ensure that the units on both sides of the equation are equivalent. If the units on both sides do not match, then the equation is either incorrect or incomplete. Dimensional analysis can also be used to derive equations for physical quantities by analyzing the dimensions of the various terms involved.

For example, $S = V_i t + \frac{1}{2} a t^2$ expresses a relation between distance, speed, acceleration and time. The dimensions of each quantity are added on both sides and then found equal i.e., [L]. So, equation is homogenous equation or dimensionally correct.

Worked Example 1.1

Show that the equation for impulse $Ft = m V_f - m V_i = m (V_f - V_i) = m \Delta V$ is dimensionally correct.

Solution:

Step 1: write above equation in dimensional form we have.

$$[M][L][T^{-2}][T] = [M][L][T]^{-1} + [M][L][T]^{-1}$$

Step 2:

Therefore $[M][L][T]^{-1} = [M][L][T]^{-1}$ and the equation is correct, both sides having the dimensions of momentum.

1.3.2 Using dimension to derive equation:

Consider the oscillations of a simple pendulum. We assume that the period of the pendulum [T] depends on following quantities:

- (i) the mass of the pendulum bob [M]
- (ii) the length of string of the pendulum [L],
- (iii) the gravitational acceleration (g) [LT⁻²]

Therefore, the equation can be written as:

$$T = k m^x l^y g^z \quad g^z = \left(\frac{L}{T^2}\right)^z = \frac{L^z}{T^{2z}}$$

Where x, y and z are unknown powers and k is a dimensionless constant.

The dimensional form above equation is

$$[T] = [M]^x [L]^y [L]^z [T]^{-2z}$$

Equating the indices for M, L and T on both left and right sides of the equation, we get:

$$M: 0 = x$$

$$L: 0 = y + z$$

$$T: 1 = -2z$$

Therefore

$$x = 0, y = \frac{1}{2} \text{ and } z = -\frac{1}{2}$$

The original equation therefore becomes

$$T = k (L/g)^{1/2}$$

Which is what we would expect for a simple pendulum. Dimensionality does not give us the value of the dimensionless constant k which can be shown by other methods to be 2π , so it becomes

$$T = 2\pi \sqrt{\frac{L}{g}} \quad \dots\dots (1.1)$$

1.3 Errors and Uncertainty:

Error and uncertainty are two related but distinct concepts in various fields, including statistics, science and engineering. Here's a distinction between these two:

Error: Error refers to the discrepancy between a measured or observed value and the true or expected value.

Uncertainty: It relates to the lack of precise knowledge or the degree of doubt associated with a measurement, prediction, or estimation. It arises due to limitations in available information or inherent variability in the system being studied.

The main difference between errors and uncertainties is that an **error is the difference between the actual value and the measured value**, while an **uncertainty is an estimate of the range between them, representing the reliability of the measurement**.

1.4.1 Uncertainty in measurements:

Any experiment will have a number of measurements and which will be made to a certain degree of accuracy. There is always a degree of uncertainty when measurements are taken; the uncertainty can be thought of as the difference between the **actual** reading taken (caused by the equipment or techniques used) and the **standard value**. Uncertainties are not the same as errors

- Errors can be because of issues with equipment or methodology that cause a reading to be different from the standard value.
- The uncertainty is a range of values around a measurement within which the true value is expected to lie, and is an **estimate**.

For example: The calculations of velocity require the movement of a time and distance. Using a stop watch to measure time nearest tenth of a second, and using a meter scale to find distance to the nearest of millimeter (for small distances in a laboratory). It is very useful to have a rough idea of the kind of result that you might expect before starting an experiment.

1.4.2 Systematic error and Random Error:

Errors are common occurrences in Physics and there are two specific types of errors that may occur during experiments.

Systematic Errors:

Systematic errors are errors that have a clear cause and can be eliminated for future experiments as shown in fig: 1.5.

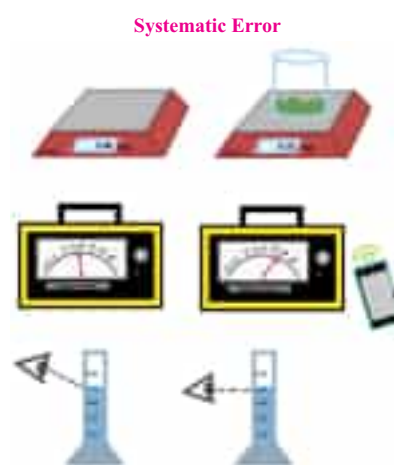

Figure 1.5

There are four different types of systematic errors:

Instrumental: When the instrument being used does not function properly causing error in the experiment (such as a scale that reads 2g more than the actual weight of the object, causing the measured values to read too high **consistently**)

Environmental: When the surrounding environment (such as a lab) causes errors in the experiment (the scientist cell phone's RF waves cause the geiger counters to incorrectly display the radiation)

Observational: When the scientist inaccurately reads a measurement wrong (such as when not standing straight-on when reading the volume of a flask causing the volume to be incorrectly measured)

Theoretical: When the model system being used causes the results to be inaccurate (such as being told that humidity does not affect the results of an experiment when it actually does)

Random Errors:

Random errors occur randomly, and sometimes have no source/cause as shown in fig:1.6.

There are two types of random errors:

Observational: When the observer makes consistent observational mistakes (such as not reading the scale correctly and writing down values that are constantly too low or too high)

Environmental: When unpredictable changes occur in the environment of the experiment (such as students repeatedly opening and closing the door when the pressure is being measured, causing fluctuations in the reading)



Figure 1.6

Systematic vs. Random Errors:

Systematic errors and random errors are sometimes similar, so here is a way to distinguish between them:

Systematic Errors are errors that occur in the same direction consistently, meaning that if the scale was off by an extra 3lbs, then every measurement for that experiment would contain an extra 3 lbs. This error is identifiable and, once identified, they can be eliminated for future experiments

Random Errors are errors that can occur in any direction and are not consistent, thus they are hard to identify and thus the error is harder to fix for future experiments. An observer might make a

mistake when measuring and record a value that's too low, but because no one else was there when it was measured, the mistake went on unnoticed.

1.4.3 Measure the diameters of a few ball bearings of different sizes and estimate their volumes. Mention uncertainty in each result. analyze and evaluate the above experiment and suggest improvements.

To measure the diameters of different-sized ball bearings and estimate their volumes, assume we have a caliper with a measurement uncertainty of ± 0.01 mm. Here's an example of measuring three ball bearings and estimating their volumes:

Ball Bearing 1:

Diameter measurement: 5.12 mm \pm 0.01 mm (using the caliper)

$$\text{Radius} = \frac{\text{diameter}}{2} = 2.56 \text{ mm} \pm 0.005 \text{ mm} = r + \Delta r$$

$$\text{Volume} = \frac{4}{3}\pi r^3 = \frac{4}{3}\pi(r + \Delta r)^3$$

$\therefore \Delta r$ is very small as compared to r so therefore square and higher power will be neglected

$$\text{Volume} = \frac{4}{3}\pi r^3 \pm 4\pi r^2 \Delta r$$

$$\begin{aligned} V \pm \Delta V &= \frac{4}{3}(3.14)(2.56)^3 \pm 4(3.14)(2.56)^2(0.005) \\ &= (70.24 \pm 0.41) \text{ mm}^3 \end{aligned}$$

Volume of ball bearing 1 is found to be 70.24 mm^3 with uncertainty of 0.41 mm^3

Ball Bearing 2:

Diameter measurement: 3.78 mm \pm 0.01 mm

$$\text{Radius} = \text{diameter}/2 = 1.89 \text{ mm} \pm 0.005 \text{ mm}$$

$$V \pm \Delta V = \frac{4}{3}\pi r^3 \pm 4\pi r^2 \Delta r$$

$$V \pm \Delta V = (28.26 \pm 0.22) \text{ mm}^3$$

Volume of ball bearing 2 is found to be 28.26 mm^3 with uncertainty of 0.22 mm^3

Ball Bearing 3:

Diameter measurement: 7.25 mm \pm 0.01 mm

$$\text{Radius} = \text{diameter}/2 = 3.62 \text{ mm} \pm 0.005 \text{ mm}$$

$$V \pm \Delta V = \frac{4}{3}\pi r^3 \pm 4\pi r^2 \Delta r$$

$$V \pm \Delta V = (198.60 \pm 0.82) \text{ mm}^3$$

Volume of ball bearing 3 is found to be 198.60 mm^3 with uncertainty of 0.82 mm^3

Analyze and evaluate the above experiment and suggest improvements.

Let's evaluate the experiment and discuss potential improvements:

Measurement Technique: The use of a caliper is a common and practical approach for measuring ball bearing diameters. However, to improve accuracy, consider using a digital caliper with higher precision and readability. This can help reduce measurement errors and enhance the quality of the results.

Replicability: To ensure the reliability of the measurements, it is advisable to take multiple readings for each ball bearing and calculate the average. This helps minimize random errors and provides a more accurate representation of the true diameter.

Calibration: Regular calibration of the measuring instrument, such as the caliper, is crucial to ensure accurate measurements. Ensure the caliper is properly calibrated before each measurement session to minimize systematic errors.

Uncertainty Analysis: While we estimated the uncertainty in the volume calculations based on the uncertainty in the radius measurement, it is important to consider other potential sources of uncertainty, such as the accuracy of the volume formula and the assumption of perfect spherical shape. A more comprehensive analysis of uncertainty should involve considering all potential sources of error.

Quality Control: Implement quality control measures to ensure the ball bearings used in the experiment have consistent shape, surface quality and are free from defects that could affect the measurements.

By addressing these points and incorporating the improvements mentioned, the experiment can yield more accurate and reliable results.

Worked Example 1.2

If the radius of sphere is measured a 9 cm with an error of 0.02 cm. Find the approximate error in calculating its volume.

Solution:

Step 1:

$R = 9 \text{ cm}$ and $\Delta R = 0.02 \text{ cm}$

Volume of sphere = $\frac{4}{3}\pi r^3$ By differentiating both sides, we get

$$\therefore \frac{\Delta V}{V} = 3 \frac{\Delta R}{R}$$

$$\frac{\Delta V}{V} = 3 \times \frac{\Delta R}{R} = 3 \times \left(\frac{0.02}{9}\right) = 0.0067$$

So, the error in volume calculation is approximately 0.67%.

Step 2:

$$V = \frac{4}{3} \pi R^3$$

$$V = \frac{4}{3} \times \pi \times (9^3) = 904 \text{ cm}^3$$

The absolute error in volume is approximately $904 \times 0.0067 = 6.1 \text{ cm}^3$

Therefore, the approximate error in calculating the volume of the sphere is 6.1 cm^3 .

Worked Example 1.3

If radius of a sphere is measured as 7.5 cm with error of 0.03 cm, find the approximate error in calculating its volume.

Solution:

Step 1:

Let R be the radius and V be the volume of the sphere, then

$$V = \frac{4}{3} \pi R^3 \quad \text{Differentiating both sides, we get}$$

Let ΔR be the error in R and the corresponding error in V is ΔV , then

$$\frac{\Delta V}{V} = 3 \times \frac{\Delta R}{R} = 3 \times \left(\frac{0.03}{7.5}\right) = 0.004$$

Step 2:

If R is given 7.5 cm and ΔR is 0.03 cm

$$V = \frac{4}{3} \pi 7.5^3 = 1767.15 \text{ cm}^3$$

The absolute error in volume is approximately $1767.15 \times 0.004 = 7.1 \text{ cm}^3$

Therefore, the approximate error in calculating the volume of a sphere is 7.1 cm^3 .

1.4.5 Uncertainty Calculation of Derived Quantities:

Uncertainty in a single measurement:

A man weighs himself on his bathroom scale. The smallest divisions on the scale are 1 Newton marks, so the least count of the instrument is 1 Newton.

He reads his weight as closest to the 142 Newton mark. He knows his weight must be larger than 141.5 Newton (or else it would be closer to the 141-newton mark), but smaller than 142.5 Newtons (or else it would be closer to the 143-newton mark). So, his weight must be

Weight = 142 ± 0.5 newtons.

In general, the uncertainty in a single measurement from a single instrument is half the least count of the instrument.

Fractional and Percentage Uncertainty

What is the fractional uncertainty in man's weight?

$$\text{Fractional Uncertainty} = \frac{\text{Uncertainty in weight}}{\text{Value for weight}}$$

Unit 1: Physics and Measurements

$$= \frac{0.5 \text{ newtons}}{142 \text{ newtons}} = 0.0035$$

What is the uncertainty in man's weight, expressed as percentage of his weight?

$$\text{Percentage Uncertainty} = \frac{0.5}{142} \times 100\% = 0.35\%$$

Combining Uncertainties: Adding or Subtracting:

The length of a copper wire at 30°C is 18.2±0.04 cm and at 60°C is 19.7±0.02 cm. Find the absolute uncertainty and the extension of the wire.

$$\text{Absolute uncertainty} = 0.04 + 0.02 = 0.06$$

$$\text{Extension of the wire} = (19.7 - 18.2) \pm 0.06$$

$$\text{Extension of the wire} = 1.5 \text{ mm} \pm 0.06$$

Multiplication or Division in an equation, percentage uncertainty of each value is added together.

The weight of an iron block is 8.0±0.3 N and is placed on a wooden base of area, 3.5±0.2 m². Find the percentage uncertainties of the values and then calculate the pressure exerted by the block.

$$\text{Percentage uncertainty in the weight} = \left(\frac{0.3}{8}\right) \times 100 = 3.75\%$$

$$\text{Percentage uncertainty in the area} = \left(\frac{0.2}{3.5}\right) \times 100 = 5.71\%$$

$$\% \text{ uncertainty} = 3.75\% + 5.71\% = 9.46\%$$

$$\text{Pressure} = \frac{8}{3.5} = 2.3 \text{ Pa}$$

$$\text{Absolute Uncertainty in the pressure} = \left(\frac{9.46}{100}\right) \times 2.3 = 0.22 - \text{absolute uncertainty} = \text{Percentage uncertainty} \times \text{mean measurement.}$$

Since both the weight and the area have been approximated to two significant figures, so the same final answer becomes same form.

$$\text{Pressure} = 2.3 \pm 0.22 \text{ Pa}$$

Worked Example 1.4

Consider the length of cube is given as 5.75±0.3 cm and you want to find absolute uncertainty in volume.

Solution:

Step 1:

$$\text{VOLUME} = L^3 = (5.75)^3 = 190 \text{ cm}^3$$

Step 2:

$$\text{Percentage uncertainty} = 3 \times \left(\frac{0.3}{5.75}\right) \times 100 = 15.65\%$$

$$\text{Absolute uncertainty in volume} = 190 \pm 15.65 \text{ cm}^3$$

Self-Assessment Questions:

A girl needs to calculate the volume of her pool, so that she knows how much water she will need to fill it. She measures the length, width and height as under:

Length = 5.56 ± 0.14 m

Width = 3.12 ± 0.08 m

height = 2.94 ± 0.11 m

What will be the pool's volume with uncertainty?

($51.0 \pm 8.8\%$)

1.5 Graph:

Graphs are visuals that show relationships between; intended to display the data in a way that is easy to understand and remember. Graphs are used to demonstrate trends, patterns and relationships between sets of data. Graphs may be preferable to display certain types of data. The graph you choose will often depend on the key points you want others to learn from the data you've collected.

1.5.1 Dependent and Independent Variables:

In statistics and mathematical modeling, dependent and independent variables are terms used to describe the relationship between two variables.

An **independent variable** is a variable that **is manipulated in an experiment or study to observe the effect it has on a dependent variable.** The independent variable is also sometimes called the predictor variable, explanatory variable, or input variable.

A **dependent variable** is a variable that is being **measured or observed in an experiment or study, and is expected to change as a result of the manipulation of the independent variable.** The dependent variable is also sometimes called the response variable, outcome variable, or output variable.

There are different types of graphs that can be used to represent the relationship between dependent and independent variables, including scatter plots, line graphs, and bar graphs. The choice of graph depends on the type of data and the nature of the relationship between the variables.

1.5.2 Best fit line graph:

A best fit line graph is a type of graph used to visualize the relationship between two variables and is used to show the general trend in the data. The line of best fit is a straight line that is drawn in a way that it best represents the underlying pattern in the data.

The line of best fit is shown in figure 1.7 and it is drawn in a way that best represents the underlying pattern in the data.

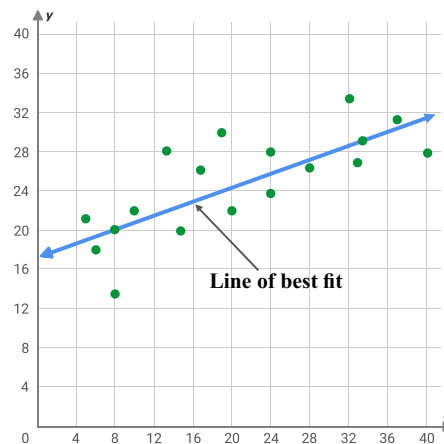

Figure 1.7

Error Bar:

Error bars are graphical representations of the uncertainty or variability in a set of data points. They are often used in scientific plots to indicate the precision of the data being plotted as shown in figure 1.8.

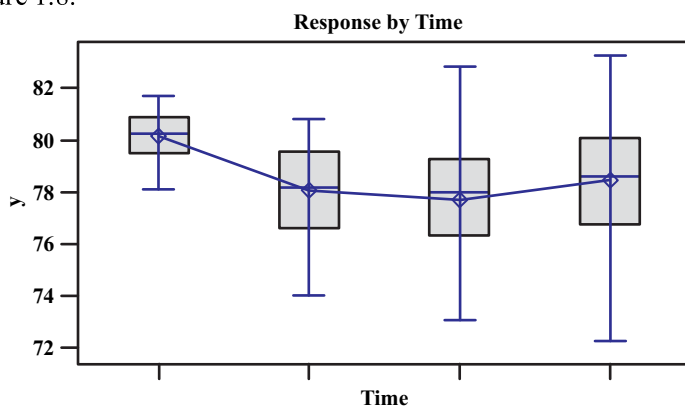

Figure 1.8

Error bars are usually plotted as vertical or horizontal lines extending from the data points on a graph. The length of the error bars indicates the degree of uncertainty or variability in the data. Shorter error bars indicate greater precision, while longer error bars indicate less precision.

Error bars are useful in indicating the reliability and accuracy of the data, and they allow the reader to assess the significance of the results. In scientific research, error bars are often used to determine the statistical significance of differences between groups or to compare the results of different experiments.

A simpler display is a plot of the mean for each time point and error bars that indicate the variation in the data.

1.5.3 Extrapolation:

Extrapolation is a statistical technique that involves using observed data to estimate values beyond the range of the data that was collected. In other words, it is the process of making predictions or estimates about future or unseen data based on the trends or patterns in the existing data.

For example, in case volume temperature graph as shown in figure 1.9, If we extrapolate the line till it intercepts the temperature axis, in result we reach zero kelvin temperature.

In summary, extrapolation is a technique used to make predictions or estimates about future or unseen data based on the trends or patterns in the existing data.

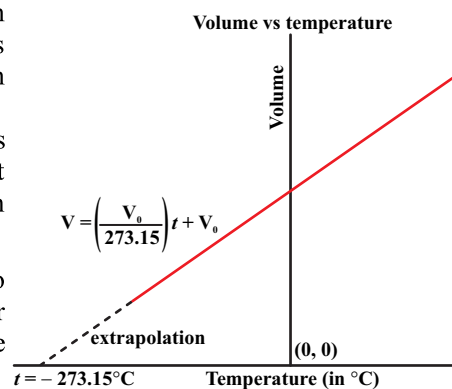

Figure 1.9

1.6 Significant Figures:

Significant figures are the digits in a number that are meaningful in terms of the precision of the measurement. They provide information about the degree of accuracy of a measurement and are used to report the results of experiments and calculations.

1.6.1: Rules of Significant Figures:

The rules for determining significant figures are as follows:

1. All non-zero digits are significant. For example, the number 12.3 has three significant figures.
2. Zeros between two non-zero digits are significant. For example, the number 102 has three significant figures.
3. Zeros to the right of the decimal point and to the right of a non-zero digit are significant. For example, the number 0.0056 has three significant figures.
4. Zeros to the left of the first non-zero digit in a number are not significant. For example, the number 0.0056 has two significant figures.
5. Zeros at the end of a number after the decimal point, but before the last non-zero digit, are significant. For example, the number 12.300 has four significant figures.

It is important to be consistent in reporting the significant figures in a calculation, as this provides information about the accuracy of the results. When performing calculations with numbers of different precision, it is necessary to round the result to the appropriate number of significant figures based on the rules above.

When performing calculations, we must consider the significant figures. When adding, subtracting, multiplying or dividing numbers, the answer should contain only as many significant figures as the number involved in the operation that has the least number of significant figures.

Example:

1. A student measures the length of a metallic rod and it was found to be 264.68 cm. While in next trial the length was measured as 247.1 cm. The error in measurement will be

$$264.68 \text{ cm} - 247.1 \text{ cm} = 17.68 \text{ cm}$$
 In this operation, the least number of significant figures in the operation is four so the final answer must have five significant figures.
2. An engineer measure the length of wall as 2.345m and width 8.3482m the area of the wall will be

$$2.345 \text{ m} \times 3.56 \text{ m} = 8.3482 \text{ m}^2 = 8.35 \text{ m}^2$$
 The final answer has three significant figures because the least number of significant figures in the operation is three that is 3.56.
3. The following values are part of a set of experimental data: 618.5 cm and 1450.6mm. Write the sum of these values correct to the right number of significant figures.

Or $1450.6/10 = 145.06\text{cm}$.

or

$618.5\text{ cm} + 145.06\text{ cm} = 763.56\text{ cm}$

The least number of significant figures in the original values is 4, so write the answer to this significance. The sum is written as 763.6cm.

Scientific Notations:

In scientific notation, a number is expressed as a power of 10 multiplied by a coefficient.

For example, the speed of light in vacuum is 299 792 458 m/s. In scientific notation, this number can be expressed as 2.99792458×10^8 m/s conveniently it can be written as 3×10^8 .

It is important to note that scientific notation does not change the value of the number, but it provides a convenient way of expressing and manipulating very large or very small numbers.

1.7.1 Least Count or Resolution:

The least count or resolution of a measuring instrument is the smallest increment that can be measured by that instrument. It is the smallest division on the scale of the instrument and represents the smallest change that can be detected in a measurement. For example, if the least count of a ruler is 0.1 cm, then it can only measure lengths to the nearest 0.1 cm. The least count or resolution of a measuring instrument determines the precision of the instrument and thus the level of detail that can be obtained from a measurement.



Figure 1.10 ruler

Least count is inversely proportional to the precision of measurement equipment. The smaller the minimum value of an instrument can measure, the lower will be L.C., and the higher will be the precision.

For better understanding, let's consider an example of digital and mechanical Vernier calipers. Since digital Vernier L.C. (0.01 mm) is smaller than mechanical Vernier L.C. (0.02 mm).

Mechanical Vernier will measure a 6 ± 0.21 mm dimension as 6 ± 0.20 mm or 6 ± 0.22 mm. Whereas digital Vernier will measure it 6 ± 0.21 . Therefore, Digital Vernier is more precise compared to mechanical Vernier because it has a smaller Least-Count.

Accuracy is also inversely proportional to the Least-Count. Accuracy of an instrument is always less than its L.C. because it cannot measure better than the minimum value it can measure.

1.7.2 Difference Between Accuracy and Precision.

Accuracy	Precision
Accuracy is referred to the level of agreement between the actual measurement and the absolute measurement.	Precision suggests the level of variation that happens in the values of several measurements of the same factor.
It represents how closely the results agree with the standard value.	Represents how closely results agree with one another.
Single-factor or measurement is required.	Multiple measurements are needed to comment about precision.
Occasionally, a measurement may happen to be accurate by chance, while consistent accuracy and precision are required for a measurement to be reliable.	Results can be precise without being accurate.

1.7.3 Significance of Resolution:

Using an instrument of smallest resolution is important for several reasons:

1. Precision: The smallest resolution of a measuring instrument determines its precision, which is the degree of reproducibility of a measurement. Using an instrument of smallest resolution ensures that the measurements are made with maximum precision and consistency.
2. Accuracy: The smallest resolution of a measuring instrument also affects its accuracy, which is the degree of closeness of a measurement to its true value. Using an instrument of smallest resolution helps to ensure that the measurement is as close as possible to the actual value of the quantity being measured.
3. Detail: The smallest resolution of a measuring instrument determines the level of detail that can be obtained from a measurement. Using an instrument of smallest resolution allows for the measurement of finer details and features, which can be important in various applications, such as scientific experiments or engineering design.
4. Reduced uncertainty: The smallest resolution of a measuring instrument is directly proportional to the reduced uncertainty in a measurement. The smaller the resolution, the smaller the uncertainty, and the more accurate the measurement.

1.7.4 Importance of Repeating Experiment:

Increasing the number of readings in an experiment is important for several reasons:

1. Improved precision: The more readings taken in an experiment, the more accurate and precise the data becomes. This is because additional readings can help to account for any random errors that may have occurred in the first few readings.
2. Reduced uncertainty: Taking more readings in an experiment reduces the uncertainty in the data, which is the degree of random error associated with a measurement. The

larger the number of readings, the smaller the uncertainty, and the more accurate the data becomes.

3. Better representation of the underlying trend: Taking multiple readings in an experiment can help to reveal underlying trends in the data. This can be especially useful in cases where the data may be affected by external known factors, or where the data may be influenced by unknown factors.
4. Increased confidence: Taking multiple readings in an experiment increases the confidence in the results of the experiment. The larger the number of readings, the more robust and reliable the data becomes, and the more likely it is to represent the true underlying relationship between variables.

In summary, increasing the number of readings in an experiment is important to improve the precision, reduce the uncertainty, better represent the underlying trend, and increase the confidence in the results of the experiment.

1.7.5 Interpreting Data from Graphs:

Linear and nonlinear graphs are graphical representations of mathematical relationships between variables. By measuring slopes and intercepts, you can interpret important information about the nature of the relationship between the variables represented on the graph.

1. **Slope** It is calculated as the change in the vertical (y) coordinate divided by the change in the horizontal (x) coordinate between two points on the line. If the slope is positive, the line or curve rises from left to right. If the slope is negative, the line or curve falls from right to left.
2. **Intercept**: The intercept of a line or curve is the point at which the line or curve crosses the vertical (y) axis. It is the value of the dependent variable (y) when the independent variable (x) is equal to zero. The intercept represents the initial value of the dependent variable.

Linear graph:

Observe on the graph as shown in figure 1.11, x - axis is showing time and Y axis is showing position. It is observed that position is linearly increasing in positive direction with the time. So, the graph is

linear.

To determine the slope and intercept of the graph in figure 1.11,

compare it with the equation of straight line

$$y = mx + c \dots\dots (1.3)$$

where m is the slope, c is the point of intercept. Now slope can be determined as

$$\text{Slope} = m = \frac{\Delta y}{\Delta x} \dots\dots (1.4)$$

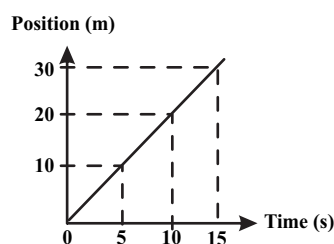

Fig. 1.11 linear graph

$$= \frac{30}{15} = 2 \text{ms}^{-1}$$

As the intercept of the line is at origin so the intercept will be zero ($c = 0$). Note that slope of a straight line always constant

Non-linear graph

In contrast to the previous example, let's graph the position of an object with a constant, non-zero acceleration starting from rest at the origin as shown in figure 1.12. The primary difference between this curve and those on the previous graph is that this line actually curves. The relation between position and time is quadratic when the acceleration is constant and therefore this curve exhibits a non-linear relationship.

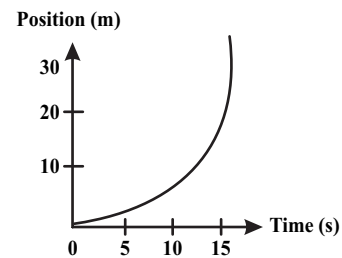
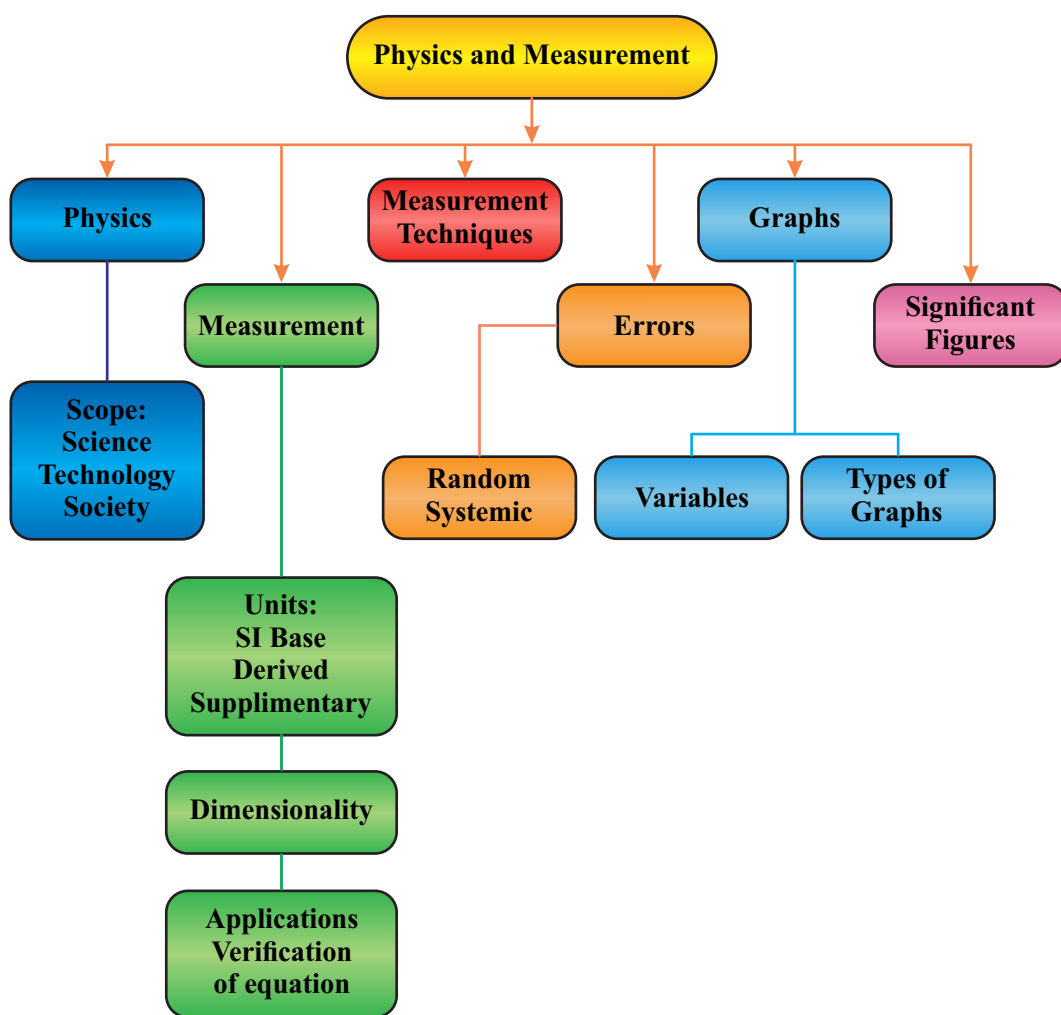

Figure 1.12 Non linear graph

Slope is a characteristic exclusive to straight lines. This emphasizes that there is no single, constant velocity in such cases. The velocity of an object under these circumstances must be undergoing change, indicating acceleration. In the case of a curved position-time graph, since the slope varies at each point along the curve, it is not possible to determine a uniform velocity by calculating the slope alone.





SUMMARY

- Physics: is a branch of science which studies the nature and behavior of matter, energy, and the interaction between them.
- Derived Unit: A derived quantity is defined based on a combination of base quantities and has a derived unit that is the exponent, product or quotient of these base units.
- Ticker Timer: The ticker timer is simply a piece of apparatus that we use to measure time.
- Electrical Quantities: The standard units of electrical measurement used for the expression of voltage, current and resistance are the Volt [V], Ampere [A] and Ohm [Ω] respectively.
- Dimensionality: The way in which the derived quantity is related to the basic quantity can be shown by the dimensions of the quantity.
- Uncertainty in measurements: Any experiment will have a number of measurements, and which will be made to a certain degree of accuracy.
- Systematic Error: These errors happen because of faulty apparatus like an incorrectly labelled scale, an incorrect zero mark on a meter or a stop watch running slowly.
- Random Error: The size of these errors depends upon how well the experimenter can use the apparatus.
- Graphs: are visuals that show relationships between; intended to display the data in a way that is easy to understand and remember. Graphs are used to demonstrate trends, patterns and relationships between sets of data.
- Independent Variable is the cause. Its value is independent of other variables in your study.
- Dependent Variable is the effect. Its value depends on changes in the independent variable.
- Significant Figures: The significant figures refer to the number of important single digit (0 through 9 inclusive) in the coefficient of an expression in scientific notation.
- Accuracy: The degree to which the result of a measurement conforms to the correct value or a standard' and essentially refers to how close a measurement is to its agreed value.
- Precision: The quality of being exact' and refers to how close two or more measurements are to each other, regardless of whether those measurements are accurate or not.
- Resolution is the ability of the measurement system to detect and faithfully indicate small changes in the characteristic of the measurement result.



EXERCISE

Section (A): Multiple Choice Questions (MCQs)

- The respective number of significant figures for the numbers 23.023, 0.0003 and 2.1×10^{-3} are:
 - 5, 1, 2
 - 5, 1, 5
 - 5, 5, 2
 - 4, 4, 2
- Which among the following is the supplementary Quantity:
 - Mass
 - Time
 - Solid angle
 - Luminosity
- The unit of solid angle is
 - Second
 - Steradian
 - Kilogram
 - Candela
- The quantity having the same unit in all system of unit is:
 - mass
 - time
 - length
 - temperature
- Random errors can be eliminated by:
 - taking number of observations and their mean.
 - measuring the quantity with more than one instrument
 - eliminating the cause
 - careful observations
- Systemic error can be:
 - either positive or negative
 - negative only
 - positive only
 - zero error
- $[MLT^{-2}]$ is dimensional formula of:
 - strain
 - force
 - displacement
 - pressure
- Which of the following pair has the same dimension?
 - moment of inertia and torque
 - impulse and momentum
 - surface tension and force
 - specific heat and latent heat
- Dependent variable is:
 - cause
 - effect
 - cause and effect
 - reason
- Dimensions of kinetic energy is the same as that of :
 - Acceleration
 - Work
 - Velocity
 - Force

Section (B): Structured Questions

CRQ's:

1. Give an example of (I) a physical quantity which has a unit but no dimensions. (II) a physical quantity which has neither unit nor dimensions. (III) a constant which has a unit. (IV) a constant which has no unit.
2. When rounding the product or quotient of two measurements, is it necessary to consider significant digit?
3. Derive the equation for period of oscillations of a mass suspended on a vertical spring by dimensional analysis. i.e., $T = 2\pi \sqrt{\frac{m}{k}}$
4. Find the dimensions of the following.
 - (a) work
 - (b) energy
 - (c) power
 - (d) momentum
5. You measure the radius of a wheel to be 4.16 cm. If you multiply by 2 to get diameter, should you write the result as 8 cm or as 8.32 cm? Justify your answer.
6. If $y = a+bt+ct^2$ where y is in meters and t in seconds, what is the unit of c ?
7. Differentiate between accuracy and precision.
8. Define dependent and independent variables.
9. Differentiate systematic error and random error.
10. Enlist the limitations of dimensional analysis?
11. Describe least count of Vernier and screw gauge micrometer.
12. Describe extrapolation methods.

ERQ's:

1. Discuss graphs and its various types by supported an example?
2. Elaborate rules of significant figures. State the rules for determining the number of significant figures in a given measurement.
3. What are the uses of dimensional analysis? Explain each of them.
4. A vernier and micrometer are shown as under. Observe their readings and write correctly.

Vernier



Micrometer



Numerical:

1. What is the percent uncertainty in the measurement 3.67 ± 0.25 m? **(6.8%)**
2. What is the area, and its approximate uncertainty, of a circle with radius 3.7×10^4 cm
 $(4.3 \pm 0.11) \times 10^9 \text{ cm}^2$
3. An aero plane travels at 850 km/h. How long does it take to travel 1.00 km? **(4.23 s)**

Unit 1: Physics and Measurements

4. A rectangular holding tank 25.0 m in length and 15.0 m in width is used to store water for short period of time in an industrial plant. If 2980 m³ water is pumped into the tank. What is the depth of the water? **(7.95 m)**
5. Find the volume of rectangular underground water tank has storage facility of 1.9 m by 1.2 m by 0.8 m. **(1.824 m³)**
6. Two students derive following equations in which x refers to distance traveled, v the speed, the acceleration, and t the time and the subscript (o) means a quantity at time t=0:
(a) $x = vt^2 + 2at$ and
(b) $x = v_o t + 2at^2$, which of these could possibly be correct according to dimensional check? **(a) Incorrect (b) Correct**
7. One hectare is defined as 10⁴ m². One acre is 4 × 10⁴ ft². How many acres are in one hectare? (Hint: 1 m = 3.28 ft.) **(2.69 acres)**
8. A watch factory claims that its watches gain or lose not more than 10 seconds in a year. How accurate is this watch, express as percentage? **(3.16×10⁻⁵ %)**
9. The diameter of Moon is 3480 km. What is the volume of the Moon? How many Moons would be needed to create a volume equal to that of Earth?
(Hint: Radius of Earth = 6380 km) **(2.2×10¹⁹ m³, 49.3)**

Unit

2

Kinematics

Teaching Periods 8

Weightage % 5



Pride of Pakistan, Muhammad Asif is a Pakistani Professional snooker player. He is two times winner of the amateur IBSF World Snooker Championship.

In this unit student should be able to:

- Describe a vector and its representation.
- Describe the Cartesian coordinate system.
- Resolve a vector into two perpendicular components.
- Describe vector nature of displacement.
- Analyze and interpret patterns of motion of objects using displacement-time graph, velocity-time graph acceleration-time graph.
- Determine the instantaneous velocity of an object moving along the same straight line by measuring the slope of displacement-time graph.
- Derive equation of uniformly accelerated motion.
- Solve the problems.
- Understand projectile motion.
- Calculate height, range and time of flight using equations of projectile motion.

Even a person without a background in physics has a collection of words that can be used to describe moving objects. Words and phrases such as going fast, stopped, slowing down, speeding up, and turning provide a sufficient vocabulary for describing the motion of objects. In physics, we use these words and many more. We will be expanding upon this vocabulary list with words such as **distance, displacement, speed, velocity, and acceleration**. As we will soon see, these words are associated with physical quantities that have different definitions. The physical quantities that are used to describe the motion of objects can be divided into two categories. The quantity is either a **vector** or a **scalar**.

Scalar Quantities:

All those physical quantities which can be specified by a magnitude and a proper unit are known as "Scalar Quantities".

Scalar quantities do not need direction for their description. Scalar quantities are added, subtracted, multiplied or divided by the simple rules of algebra.

Examples:

Work, electric flux, volume, viscosity, density, power, temperature and electric charge etc.

Vectors Quantities:

All those physical quantities having both magnitude and direction with proper unit and also obeys the Vector Algebra are known as "Vector Quantities".

We can not specify a vector quantity without mention its direction.

Examples:

Displacement, Velocity, acceleration, force, momentum, etc.

Representation of Vectors:

Vector quantities can be represented in two ways

- Analytical Or Symbolic representation
- Graphical representation

Analytical Or Symbolic representation:

In analytical method vectors are denoted by a letter with arrow or bold letters such as:

\vec{A}, \vec{B} , or $\mathbf{a}, \mathbf{b}, \mathbf{A}, \mathbf{C}$

Graphical representation:

In graphical method vectors are denoted by a line segment with arrow, the starting point of line is called tail and the ending point of line having arrow is known as head of vector. The length of line showing the magnitude of given vector as shown in figure2.1

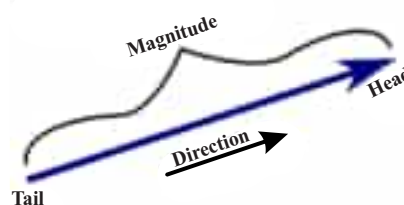

Fig: 2.1 Representation of vector

Addition of vectors by Head to Tail method (Graphical Method):

Head to Tail method or graphical method is one of the easiest methods used to find the resultant vector of two or more than two vectors.

Consider two vectors \vec{A} and \vec{B} acting in the directions as shown in figure 2.2:

Head to tail rule is a method of vector addition in which tail of second vector is connected by head of first vector. All vectors are connected in this way.

Finally, from tail of first vector to the head of last vector we will draw a vector called resultant vector.

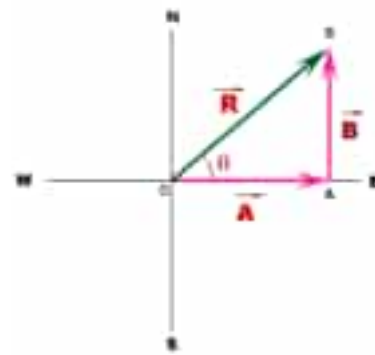

Fig: 2.2
Addition of vectors A and B

Mathematically for resultant vector 'R'

$$\vec{OB} = \vec{OA} + \vec{AB}$$

$$\vec{R} = \vec{A} + \vec{B} \dots\dots(2.1)$$

Addition of Vectors:

Properties of vector addition:

Commutative law of vector addition:

Consider two vectors \vec{A} and \vec{B} . Let these two vectors represent two adjacent sides of a parallelogram. We construct a parallelogram OACB as shown in the diagram. The diagonal OC represents the resultant vector \vec{R} .

$$\vec{R} = \vec{A} + \vec{B}$$

$$\vec{R} = \vec{B} + \vec{A}$$

Therefore

$$\vec{A} + \vec{B} = \vec{B} + \vec{A} \dots\dots(2.2)$$

This fact is referred to as the commutative law of vector addition. It shows that the order in which vectors are added has no physical significance as shown in figure 2.3.

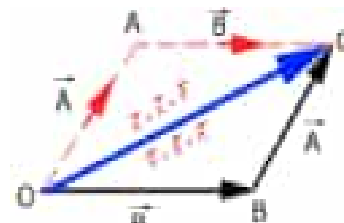

Fig: 2.3

Associative law of vector addition:

The law states that the sum of vectors remains the same irrespective of their order or grouping in which they are arranged.

Consider three vectors \vec{A} , \vec{B} and \vec{C}

Applying "head to tail rule" to obtain the resultant of $(\vec{A} + \vec{B})$ and $(\vec{B} + \vec{C})$. Then finally again find the resultant of these three vectors:

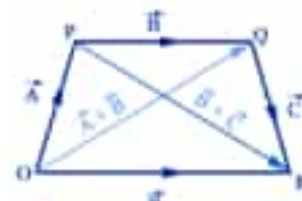

Fig: 2.4

$$\vec{OR} = \vec{OP} + \vec{PR} \text{ Or}$$

$$\vec{R} = \vec{A} + (\vec{B} + \vec{C}) \longrightarrow (i)$$

and

$$\vec{OR} = \vec{OQ} + \vec{QR}$$

$$\vec{R} = (\vec{A} + \vec{B}) + \vec{C} \longrightarrow (ii)$$

Thus from eq. (i) and (ii)
 $\vec{A} + (\vec{B} + \vec{C}) = (\vec{A} + \vec{B}) + \vec{C} \dots\dots (2.3)$

This fact is known as the Associative Law of Vector Addition as shown in figure 2.4.

Magnitude of resultant vector:

Magnitude of resultant vector can be determined by using either Cosine law or Sine law.

Resultant by cosine law $R = \sqrt{A^2 + B^2 - 2AB\cos < OAB} \dots\dots (2.4)$

Resultant by sine law $\frac{A}{\sin\alpha} = \frac{B}{\sin\beta} = \frac{R}{\sin\theta} \dots\dots (2.5)$

Multiplication and division of vector by number:

A vector can be multiplied and divided by a number using simple algebraic rules. In case of multiplication/division by positive number (non zero) only changes the magnitude of given vector. If number is negative then the change comes in the direction of vector also as shown in figure 2.5 (a) and (b).

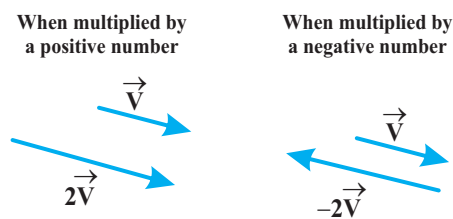

Figure 2.5 (a) and (b): multiplication of vector by positive and negative number

DO YOU KNOW?

The product of a vector \vec{V} by a scalar quantity (m) follows the following rules:

- $(m) \vec{V} = \vec{V} (m)$... commutative law of multiplication.
- $m(n\vec{V}) = (mn) \vec{V}$... associative law of multiplication.
- $(m + n) \vec{V} = m \vec{V} + n \vec{V}$... distributive law of multiplication.

Self-Assessment Questions:

1. What happens to the direction of a vector when it undergoes scalar multiplication?
2. If vector A has components (3, -2) and vector B has components (-1, 5), what are the components of A + B?

Cartesian coordinate system:

Cartesian coordinate system is a set of three mutually perpendicular lines (X-axis, Y-axis and Z-axis) with common initial point called origin used to find out location of any point as shown in figure 2.6.

Such as you are presenting data on a line graph, or simply finding the location of a car park on a map of a National Park, you will need to have an understanding of coordinates.

There are many coordinate systems among them Cartesian or Rectangular coordinate system is one of most used and easy to understand.

In a rectangular coordinate system, vectors can be classified into different types based on their characteristics and properties. Here are some commonly defined types of vectors in relation to a rectangular coordinate system:

Unit vector:

"A unit vector is defined as a vector in any specified direction whose magnitude is unity i.e. 1. A unit vector only specifies the direction of a given vector."

A unit vector can be determined by dividing the vector by its magnitude.

For example, unit vector of a vector A is given by:

$$\hat{a} = \frac{\vec{A}}{A} \dots\dots (2.6)$$

The symbol is usually a lowercase letter with a "hat / cap / circumflex", such as:

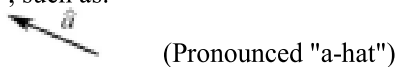

In three dimensional coordinate system unit vectors ($\hat{i}, \hat{j}, \hat{k}$) having the direction of the positive X-axis, Y-axis and Z-axis are used as unit vectors. These unit vectors are mutually perpendicular to each other as shown in fig: 2.7.

Free vector:

A free vector can be moved or translated without changing its essential characteristics, such as magnitude and direction.

It is represented by an arrow and is not attached to any specific point in space. Consider a free vector \vec{A} changing its position in XYZ plane without changing its direction and magnitude is an example of free vector as shown in fig: 2.8

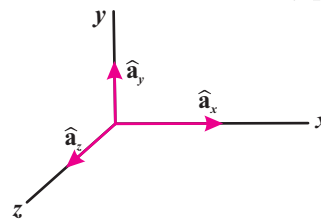

Fig: 2.6 Cartesian coordinates

DO YOU KNOW?

Equal Vectors
Two vectors are considered equal if they have the same magnitude and direction

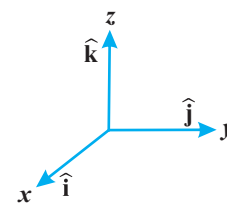

Fig: 2.7 Unit vectors i, j, k

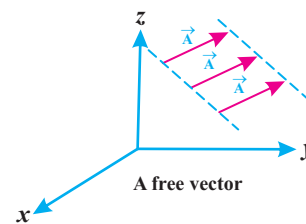

Fig: 2.8 free vector

Position vector:

A Vector that indicates the position of a point in a coordinate system is referred to as **position vector**.

Suppose we have a fixed reference point O, then we can specify the position of a given point P with respect to point O by means of a vector having magnitude and direction represented by a directed line segment OP, this vector is called position vector and represented by \vec{r} as shown in figure 2.9.

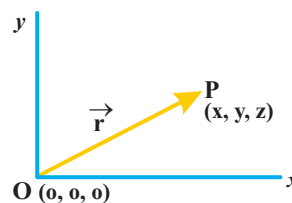

Fig: 2.9 position vector

These are some of the types of vectors commonly encountered in a rectangular coordinate system. Understanding these types and their properties can be helpful in various mathematical and physical applications involving vectors.

Resolution of vector:

The process of splitting a vector into rectangular components is called "RESOLUTION OF VECTOR". We can resolve a vector into three components. Such as **x-component, y-component, z-component along the three axis of coordinates system respectively.**

These components are called rectangular components of vector.

Method of resolving a vector into rectangular components:

Consider a vector \vec{V} acting at a point making an angle θ with positive X axis. Vector \vec{V} is represented by a line OA as shown in fig: 2.10. From point A draw a perpendicular AB on X-axis. Suppose OB and BA represents two vectors. Vector OB is parallel to X-axis and vector BA is parallel to Y-axis. Magnitude of these vectors are V_x and V_y respectively. By the method of head to tail we notice that the sum of these vectors is equal to vector \vec{V} .

Thus V_x and V_y are the rectangular components of vector \vec{V}

V_x = Horizontal component of \vec{V} along x-axis

V_y = Vertical component of \vec{V} along y-axis

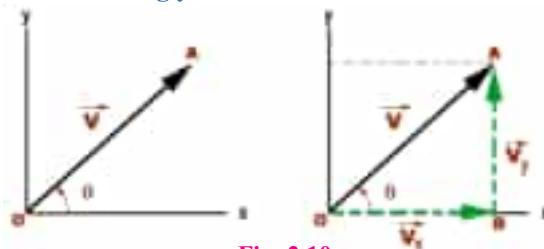

Fig: 2.10

DO YOU KNOW?

two vector equal in magnitude but opposite in direction are known as **negative vector** of each other.

a null vector is a resultant vector of two equal vectors acting in opposite directions.

$$\vec{0} = \vec{A} + (-\vec{A}) = |0|$$

Magnitude of horizontal component

Consider right angled triangle

$$\cos \theta = \frac{\overline{OB}}{\overline{OA}}$$

$$\overline{OB} = \overline{OA} \cos \theta$$

$$\boxed{V_x = V \cos \theta}$$

Magnitude of vertical component

Consider right angled triangle

$$\sin \theta = \frac{\overline{BA}}{\overline{OA}}$$

$$\overline{BA} = \overline{OA} \sin \theta$$

$$\boxed{V_y = V \sin \theta}$$

Direction of the Vector

$$\tan \theta = \frac{\overline{BA}}{\overline{OB}}$$

$$\tan \theta = \frac{V_y}{V_x}$$

Addition of vectors by rectangular components method:

Consider two vectors \vec{V}_1 and \vec{V}_2 making angles θ_1 and θ_2 with +ve x-axis respectively.

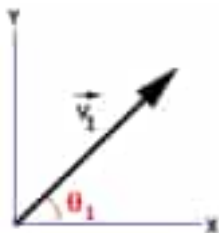

Fig: 2.11 (a)



Fig: 2.11 (b)



Fig: 2.11 (c)

Resolve vector \vec{V}_1 into two rectangular components \vec{V}_{1x} and \vec{V}_{1y} as shown in fig: 2.11 (c).

Magnitude of these components are:

$$V_{1x} = V_1 \cos \theta_1$$

and

$$V_{1y} = V_1 \sin \theta_1$$

Resolve vector \vec{V}_2 into two rectangular components V_{2x} and V_{2y} as shown in figure 2.11(c)
 Magnitude of these components are:

$$V_{2x} = V_2 \cos \theta_2$$

and

$$V_{2y} = V_2 \sin \theta_2$$

Now move vector \vec{V}_2 parallel to itself so that its initial point (tail) lies on the terminal point (head) of vector \vec{V}_1 as shown in the Fig: 2.11 (c).

Representative lines of \vec{V}_1 and \vec{V}_2 are OA and OB respectively. Join O and B which is equal to resultant vector of \vec{V}_1 and \vec{V}_2

Resultant vector along X-axis can be determined as:

$$\overline{OD} = \overline{OC} + \overline{CD}$$

$$\overline{OD} = \overline{OC} + \overline{AE} \quad \therefore \overline{CD} = \overline{AE}$$

$$\vec{R}_x = \vec{V}_{1x} + \vec{V}_{2x}$$

$$\vec{R}_x = V_1 \cos \theta_1 + V_2 \cos \theta_2 \dots\dots(2.7)$$

Resultant vector along Y-axis can be determined as:

$$\overline{DB} = \overline{CA} + \overline{EB}$$

$$\overline{OD} = \overline{DE} + \overline{EB} \quad \therefore \overline{CA} = \overline{DE}$$

$$\vec{R}_y = \vec{V}_{1y} + \vec{V}_{2y}$$

$$\vec{R}_y = V_1 \sin \theta_1 + V_2 \sin \theta_2 \dots\dots(2.8)$$

Now we will determine the magnitude of resultant vector by using the Pythagoras' theorem.

$$\text{Hypotenous}^2 = \text{Base}^2 + \text{Perpendicular}^2$$

$$|\overline{OB}|^2 = |\overline{OD}|^2 + |\overline{DB}|^2$$

$$R^2 = R_x^2 + R_y^2$$

$$R = \sqrt{R_x^2 + R_y^2}$$

$$R = \sqrt{(V_1 \cos \theta_1 + V_2 \cos \theta_2)^2 + (V_1 \sin \theta_1 + V_2 \sin \theta_2)^2} \dots\dots(2.9)$$

Finally the direction of resultant vector will be determined.

Again in the right angled triangle $\triangle DOB$:

$$\tan \angle DOB = \frac{\overline{DB}}{\overline{OD}}$$

$$\tan \angle DOB = \tan \theta = \frac{R_y}{R_x}$$

$$\theta = \tan^{-1} \left(\frac{R_y}{R_x} \right) \dots\dots(2.10)$$

Where θ is the angle that the resultant vector makes with the positive X-axis. In this way we can add a number of vectors in a very easy manner. This method is known as *addition of vectors by rectangular components method*.

Self-Assessment Questions:

1. Define a unit vector and its significance in vector representation.
2. What is a position vector, and how is it used in Cartesian coordinates?

Product of two vectors:

There are two types of vector product which can be classified as

- Scalar product (Dot product)
- Vector product (Cross product).

Scalar or dot product:

The scalar product of two vectors \vec{A} and \vec{B} is written as $\vec{A} \cdot \vec{B}$ and is defined as,

“When two parallel vectors are multiplied, their resultant quantity will be a scalar, this is called scalar or dot product.”

$$\vec{A} \cdot \vec{B} = AB \cos \theta \dots\dots(2.11)$$

Where A and B are the magnitudes of vectors A and B and θ is the angle between them.

For physical interpretation of dot product of two vectors A and B, these are first brought to a common origin.

Then, $\vec{A} \cdot \vec{B} = (A) (\text{projection of } B \text{ on } A)$

As shown in fig: 2.12.

$$\vec{A} \cdot \vec{B} = A (\text{magnitude of component of } B \text{ in the direction of } A)$$

$$\vec{A} \cdot \vec{B} = A (B \cos \theta) = AB \cos \theta$$

Similarly

$$\vec{B} \cdot \vec{A} = B (A \cos \theta) = BA \cos \theta$$

We come across this type of product when we consider the work done by a force F whose point of application moves a distance d in a direction making an angle θ with the line of action of F, as shown in fig: 2.13.

$$\text{Work done} = \text{Force} \times \text{Displacement}$$

$$\text{Work done} = Fd \cos \theta$$

$$F \cdot d = Fd \cos \theta = \text{work done}$$

Where θ is the angle between \vec{F} and \vec{d}

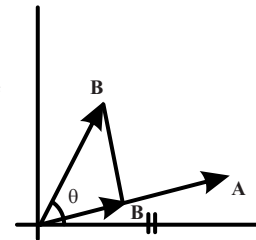

Fig: 2.12

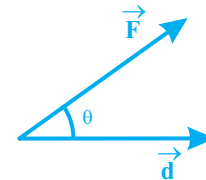

Figure 2.13

Worked Example 2.1

Find $\vec{a} \cdot \vec{b}$ when $\vec{a} = \hat{i} - 2\hat{j} + \hat{k}$ and $\vec{b} = 3\hat{i} - 4\hat{j} - 2\hat{k}$

Step 1:

$$\vec{a} = \hat{i} - 2\hat{j} + \hat{k}$$

$$\vec{b} = 3\hat{i} - 4\hat{j} - 2\hat{k}$$

$$\vec{a} \cdot \vec{b} = (\hat{i} - 2\hat{j} + \hat{k}) \cdot (3\hat{i} - 4\hat{j} - 2\hat{k}) = 3 + 8 - 2$$

Step 2: $\vec{a} \cdot \vec{b} = 9$

$$\therefore \hat{i} \cdot \hat{j} = \hat{k} \cdot \hat{j} = \hat{i} \cdot \hat{k} = 0$$

$$\therefore \hat{i} \cdot \hat{i} = \hat{j} \cdot \hat{j} = \hat{k} \cdot \hat{k} = 1$$

Characteristics of scalar product:

$$\vec{A} \cdot \vec{B} = AB \cos \theta$$

$$\vec{B} \cdot \vec{A} = BA \cos \theta$$

It can be used to find the angle between two vectors.

$$\vec{A} \cdot \vec{B} = \vec{B} \cdot \vec{A}$$

- The order of multiplication is irrelevant. In other words scalar product is commutative.
- The scalar product of two mutually perpendicular vectors is zero, hence these vectors are also called as Orthogonal vectors.

$$\vec{A} \cdot \vec{B} = AB \cos 90^\circ = 0 \quad \text{since } \cos 90^\circ = 0 \text{ as shown in fig:2.14}$$

- In case of unit vectors \hat{i} , \hat{j} and \hat{k} , since they are mutually perpendicular, therefore,

$$\hat{i} \cdot \hat{j} = \hat{j} \cdot \hat{k} = \hat{k} \cdot \hat{i} = 0$$

- The scalar product of two parallel vectors is equal to the product of their magnitudes. Thus, for parallel vectors ($\theta = 0^\circ$)

$$\vec{A} \cdot \vec{B} = AB \cos 0^\circ = AB \quad \text{since } \cos 0^\circ = 1$$

- In case of unit vectors

$$\hat{i} \cdot \hat{i} = \hat{j} \cdot \hat{j} = \hat{k} \cdot \hat{k} = 1$$

- And for antiparallel vectors ($\theta = 180^\circ$)

$$\vec{A} \cdot \vec{B} = AB \cos 180^\circ = -AB \quad \text{since } \cos 180^\circ = -1$$

- The self-product of a vector A is equal to square of its magnitude.

$$\vec{A} \cdot \vec{A} = AA \cos 0^\circ = A^2$$

- Scalar product of two vectors A and B in terms of their rectangular components

$$\vec{A} \cdot \vec{B} = (A_x \hat{i} + A_y \hat{j} + A_z \hat{k}) \cdot (B_x \hat{i} + B_y \hat{j} + B_z \hat{k})$$

$$A \cdot B = A_x B_x + A_y B_y + A_z B_z$$

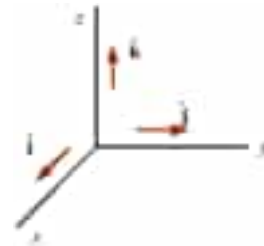

Vector or cross product:

The vector product of two vectors A and B, is a vector which is defined as

“When two perpendicular vectors are multiplied, their resultant quantity will be a vector, this is called vector or cross product.”

$$\vec{A} \times \vec{B} = AB \sin \theta \hat{n} \dots\dots(2.12)$$

Where \hat{n} is a unit vector perpendicular to the plane containing A and B as shown in fig: 2.15. its direction can be determined by right hand rule. For that purpose, place together, the tails of vectors A and B to define the plane of vectors A and B. the direction of the product vector is perpendicular to this plane. Rotate the first vector A into B through the smaller of the two possible angles and curl the fingers of the right hand in the

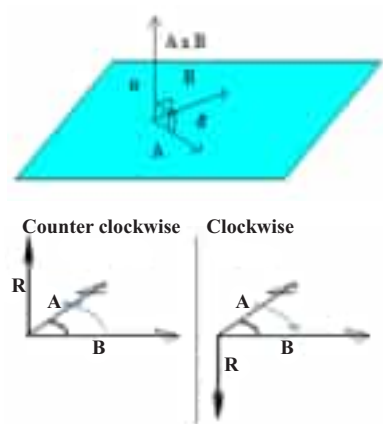

Fig: 2.15

direction of rotation, keeping the thumb upright. The direction of the product vector will be along the upright thumb, as shown in the fig: 2.15. because of this direction rule, $B \times A$ is a vector opposite in sign to $A \times B$ as shown in fig: 2.16. Hence,

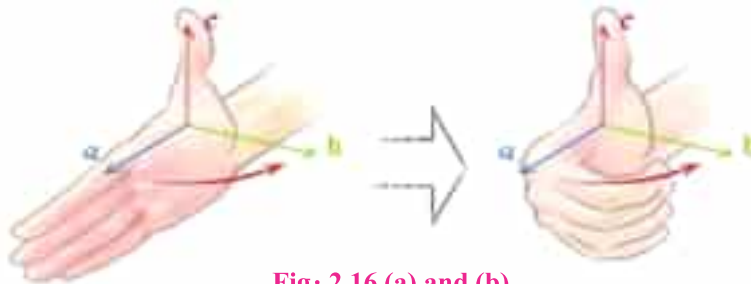

Fig: 2.16 (a) and (b)

Characteristics of cross product:

- Since $A \times B$ is not the same as $B \times A$, the cross product is non-commutative.

$$A \times B = -B \times A$$

- The vector product is associative i.e. if m is a scalar, then

$$(m A) \times B = A \times (m B) = m (A \times B)$$

- Vector product is distributive over the addition i.e.

$$A \times (B + C) = A \times B + B \times C$$

$$(A \times B) + C = A \times C + B \times C$$

- The cross product of two perpendicular vectors has maximum magnitude

$$A \times B = AB \sin 90^\circ \hat{n} \quad \text{since } \sin 90^\circ = 1$$

$$= AB \hat{n}$$

- The cross product of two parallel vectors is null vector, because for such vectors $\theta = 0^\circ$ or 180° . Hence

$$A \times B = AB \sin 0^\circ \hat{n} \quad \sin 0^\circ = 0, \sin 180^\circ = 0$$

$$A \times B = AB \sin 180^\circ \hat{n}$$

$$A \times B = 0$$

As a consequence

$$A \times A = 0$$

Also

$$\hat{i} \times \hat{i} = \hat{j} \times \hat{j} = \hat{k} \times \hat{k} = 0$$

- In case of unit vectors, since they form a right handed system and are mutually perpendicular.

$$\hat{i} \times \hat{j} = \hat{k},$$

$$\hat{j} \times \hat{k} = \hat{i},$$

$$\hat{k} \times \hat{i} = \hat{j}$$

Cross product of two vectors A and B in terms of their rectangular components is:

$$A \times B = (A_x \hat{i} + A_y \hat{j} + A_z \hat{k}) \times (B_x \hat{i} + B_y \hat{j} + B_z \hat{k})$$

$$A \times B = (A_y B_z - A_z B_y) \hat{i} + (A_z B_x - A_x B_z) \hat{j} + (A_x B_y - A_y B_x) \hat{k}$$

Cross product or vector product can be written as,

$$A \times B = \begin{vmatrix} i & j & k \\ A_x & A_y & A_z \\ B_x & B_y & B_z \end{vmatrix}$$

The magnitude of $A \times B$ is equal to the area of the parallelogram formed with A and B as two adjacent sides as shown in fig: 2.17.

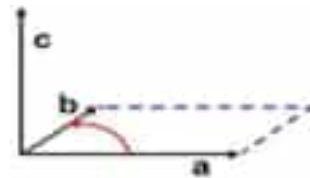

Fig:2.17 cross product of $A \times B$

Examples of vector product:

When a force F is applied on a rigid body at a point whose position vector is r from any point of the axis about which the body rotates, then the turning effect of the force, called the torque

$$\vec{\tau} = \vec{r} \times \vec{F}$$

Lets consider the Force of 5N is acts perpendicularly on edge of door to open it, the distance from the axis is 2m. calculate the torque produced.

$$\vec{\tau} = 2m \times 5N$$

$$\vec{\tau} = 10Nm$$

The force on a particle of charge q and velocity v in a magnetic field of strength B is given by vector product.

$$\vec{F} = q(\vec{v} \times \vec{B})$$

Position Vector Or Displacement vector:

A vector \vec{r} which is directed towards the point P in rectangular coordinate system is known as position or displacement vector. The position vector can be written in terms of its components as shown in fig:2.18.

$$\vec{r} = r_x\hat{i} + r_y\hat{j} + r_z\hat{k}$$

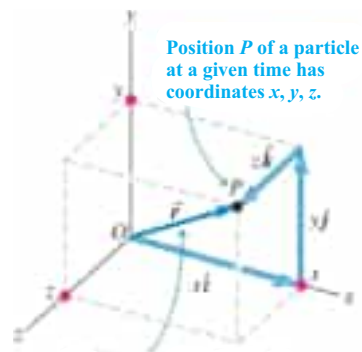

Position vector of point P has components x, y, z.

Fig: 2.18

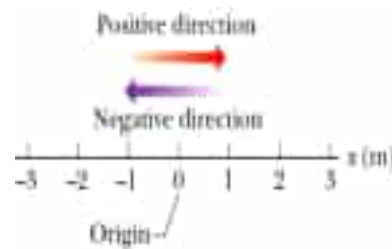

Self-Assessment Questions:

1. If two vectors A and B are parallel to each other, what is the value of their cross product?
2. If vector A has components (2, -3, 5) and vector B has components (-1, 4, 2), what is their dot product $A \cdot B$?

Speed and velocity:

Speed is a measurement of how fast an object moves relative to a reference point. It does not have a direction and is considered a magnitude or scalar quantity. So we can also consider the speed as the magnitude of velocity. Speed can be figured by the formula:

Speed = Distance/Time

or
 $s = d/t$

- The direction of \vec{V}_{av} is the same as the displacement $\Delta\vec{r}$.
- The standard unit for speed is m/s.
- Dimensional formula of speed is $[LT^{-1}]$.
 There are different types of speed Such as:

Average speed:

The average speed of an object is greater than or equal to the magnitude of the average velocity over a given interval of time. The two are equal only if the path length is equal to the magnitude of the displacement.

Uniform Speed:

If an object covers equal distances in equal intervals of time than the speed of the moving object is called uniform speed. In this type of motion, position – time graph is always a straight line.

Instantaneous speed:

Instantaneous speed is the speed of an object at any particular moment in time. It is different from average speed because average speed is the total distance divided by total time.

In this measurement, the time $\Delta t \rightarrow 0$.

$$v = \lim_{\Delta t \rightarrow 0} \frac{\Delta s}{\Delta t} \dots\dots(2.13)$$

Instantaneous speed

Velocity:

When an object is in motion, its position changes with time. But how fast is the position changing with time and in what direction? To describe this, we define the quantity average velocity. Average velocity is defined as the change in position or displacement (Δx) divided by the time intervals (Δt), in which the displacement occurs:

The rate of change of displacement of an object in a particular direction with respect to time is called velocity.

$$\text{Velocity} = \text{Displacement} / \text{Time}$$

Velocity is a vector quantity its SI unit is meter per second (m/s). Its dimensional formula is $[L T^{-1}]$.

Displacement-time graphs:

In physics graph is very powerful tool to find out the visually relation between two quantities.

DO YOU KNOW?

Two dimensions

the position of an object is described by its position vector $\vec{r}(t)$ always points to particle from origin. Displacement can be measured as

$$\begin{aligned} \Delta\vec{r} &= \vec{r}_2 - \vec{r}_1 \\ \Delta\vec{r} &= \Delta x\hat{i} - \Delta y\hat{j} \end{aligned}$$

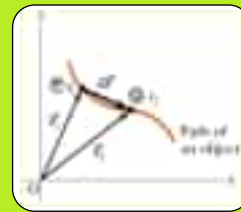

Displacement-time graphs show how the displacement of a moving object changes with time as shown in Fig: 2.19.

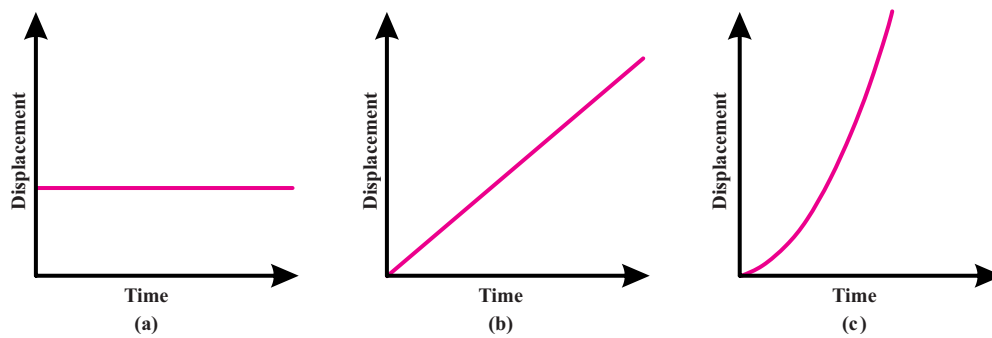

Figure 2.19 (a) Zero velocity (b) Uniform velocity (c) Variable velocity

Average velocity:

It is the total displacement covered by a body divided by total time taken as the graph of average velocity given in the fig:2.20 (a) and (b).

- If the instantaneous velocity of a body becomes equal to the average velocity, then body is said to be moving with uniform velocity.
- Mathematically average velocity of a body can be written as:

$$\text{Average velocity } \vec{v}_{avg} \equiv \frac{\Delta \vec{r}}{\Delta t}$$

$$\vec{v}_{avg} = \frac{\Delta x}{\Delta t} \hat{i} + \frac{\Delta y}{\Delta t} \hat{j} = v_{avg,x} \hat{i} + v_{avg,y} \hat{j}$$

Instantaneous velocity is the speed of an object at any particular moment in time. In this measurement, the time $\Delta t \rightarrow 0$. \vec{v} is tangent to the path in x-y graph;

$$\vec{v} \equiv \lim_{t \rightarrow 0} \vec{v}_{avg} = \lim_{t \rightarrow 0} \frac{\Delta \vec{r}}{\Delta t} = \frac{d\vec{r}}{dt} \dots\dots(2.14)$$

$$\vec{v} = \frac{d\vec{r}}{dt} = \frac{dx}{dt} \hat{i} + \frac{dy}{dt} \hat{j} = v_x \hat{i} + v_y \hat{j}$$

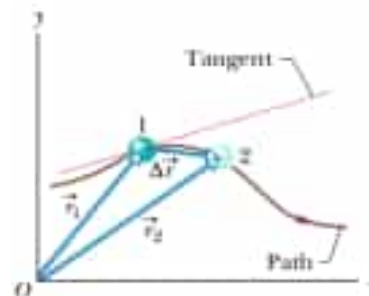

Fig: 2.20 (a)

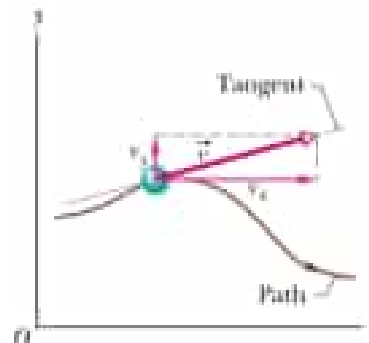
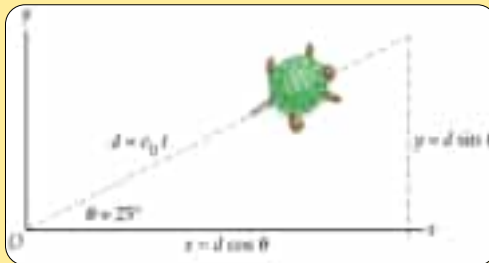

Fig: 2.20 (b)

Worked Example 2.2

A turtle starts at the origin and moves with the speed of $v_0=10$ cm/s in the direction of 25° to the horizontal.

- (a) Find the coordinates of a turtle 10 seconds later.
 (b) How far did the turtle walk in 10 seconds?



(a)

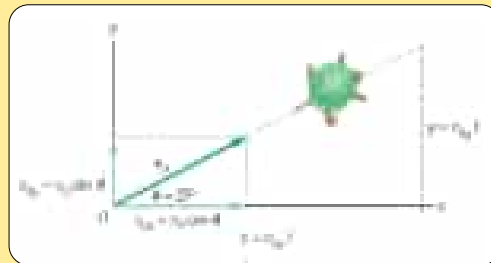

(a)

Step 1: you can solve the equations independently for the horizontal (x) and vertical (y) components of motion and then combine them!

$$\vec{v}_0 = \vec{v}_x + \vec{v}_y$$

- X components:

$$v_{0x} = v_0 \cos 25^\circ = 9.06 \text{ cm/s}$$

$$\Delta x = v_{0x} t = 90.6 \text{ cm}$$

- Y components:

$$v_{0y} = v_0 \sin 25^\circ = 4.23 \text{ cm/s}$$

$$\Delta y = v_{0y} t = 42.3 \text{ cm}$$

Step 2:

- Distance from the origin:

$$d = \sqrt{\Delta x^2 + \Delta y^2} = 100.0 \text{ cm}$$

Acceleration:

Acceleration can be defined as the change in velocity with respect to time.

Acceleration = Change in velocity / time taken

- It is a vector quantity, Its SI unit is (m/s^2) .
- Its dimension is $[\text{L T}^{-2}]$.
- It may be positive, negative or zero.

Positive Acceleration:

If the velocity of an object increases with time, its acceleration is positive.

Negative Acceleration:

If the velocity of an object decreases with time, its acceleration is negative. The negative acceleration is also called retardation or deceleration graph of retardation is given in the fig: 2.21.

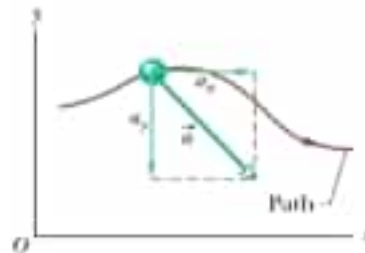

Fig: 2.21

(i) Uniform acceleration: A body is said to have uniform acceleration if magnitude and direction of the acceleration remains constant during motion.

Note: If a particle is moving with uniform acceleration, this does not necessarily imply that particle is moving in straight line. e.g. Projectile motion.

(ii) Non-uniform acceleration: A body is said to have non-uniform acceleration, if magnitude or direction or both, change during motion.

Average & Instantaneous Acceleration:

Average acceleration:

The direction of average acceleration vector is the direction of the change in velocity vector as

$$\vec{a}_{avg} \equiv \frac{\Delta \vec{v}}{\Delta t}$$

$$\vec{a}_{avg} = \frac{\Delta v_x}{\Delta t} \hat{i} + \frac{\Delta v_y}{\Delta t} \hat{j} = a_{avg,x} \hat{i} + a_{avg,y} \hat{j}$$

Instantaneous acceleration:

$$\vec{a} \equiv \lim_{t \rightarrow 0} \vec{a}_{avg} = \lim_{t \rightarrow 0} \frac{\Delta \vec{v}}{\Delta t} = \frac{d\vec{v}}{dt} \quad \vec{a} = \frac{d\vec{v}}{dt} = \frac{dv_x}{dt} \hat{i} + \frac{dv_y}{dt} \hat{j} = a_x \hat{i} + a_y \hat{j} \quad \dots\dots(2.15)$$

Instantaneous acceleration is defined as. The ratio of change in velocity during a given time interval such that the time interval approaches to zero.

- The magnitude of the velocity (the speed) can change
- The direction of the velocity can change, even though the magnitude is constant
- Both the magnitude and the direction can change

On $V_x - t$ graph the slope of the tangent is the instantaneous acceleration for a particle.

Equations of Motion For Uniform Acceleration:

Every motion can be described in terms of displacement, distance, velocity, acceleration, time. The relations between these quantities are known as the equations of motion. In case of uniform acceleration, there are three equations of motion. Hence, these equations are used to derive the components like displacement(s), velocity (initial and final), time(t) and acceleration(a). Therefore they can only be applied when acceleration is constant and motion is in a straight line. The three equations are,

$$V_f = V_i + at$$

$$V_f^2 = V_i^2 + 2as$$

$$S = V_i t + \frac{1}{2}at^2$$

Where displacement (s), initial velocity (V_i), final velocity (V_f), acceleration (a) and time (t).

- Equations of kinematics are valid for uniform acceleration.

Derivation of Equation of Motion:

The equations of motion can be derived using the following methods:

- Derivation of equations of motion by Simple Algebraic Method
- Derivation of equations of Motion by Graphical Method

In the previous classes you have learn to derive these equation by algebraic methods, In this sections, the equations of motion are derived by graphical method

Derivation of First Equation of Motion by Graphical Method:

The first equation of motion can be derived using a velocity-time graph for a moving object with an initial velocity of u , final velocity v , and acceleration a .

In the figure 2.22,

The velocity of the body changes from A to B in time t at a uniform rate.

BC is the final velocity and OC is the total time t .

A perpendicular is drawn from B to OC , a parallel line is drawn from A to D , and another perpendicular is drawn from B to OE (represented by dotted lines).

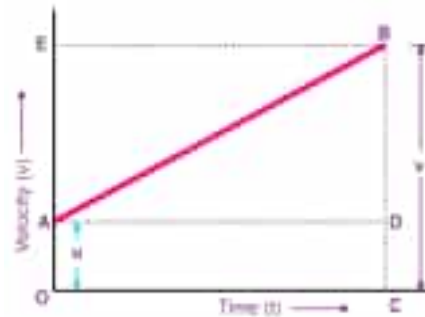

Fig: 2.22

Following details are obtained from the graph above:

The initial velocity of the body, $u = OA$

The final velocity of the body, $v = BC$

From the graph, we know that

$$BC = BD + DC$$

$$\text{Therefore, } v = BD + DC$$

$$v = BD + OA \text{ (since } DC = OA)$$

Finally,

$$v = BD + u \text{ (since } OA = u) \dots \dots \dots (i)$$

Now, since the slope of a velocity – time graph is equal to acceleration a ,

So,

$$a = \text{slope of line } AB$$

$$a = BD/AD$$

Since $AD = AC = t$, the above equation becomes:

$$BD = at \dots \dots \dots (ii)$$

Now, combining Equation (i) & (ii), the following is obtained:

$$v = u + at$$

Unit 2: Kinematics

Derivation of Second Equation of Motion by Graphical Method

From the fig: 2.23, we can say that

Distance travelled (s) = Area of figure OABC

$$= \text{Area of triangle ABD} + \text{Area of rectangle OADC}$$

$$s = \left(\frac{1}{2} \times BD \times AD\right) + (OA \times OC)$$

Since $OA = u$, $OC = AD = t$ the above equation becomes

$$s = \left(\frac{1}{2} \times BD \times t\right) + (u \times t)$$

As: $BD = AE = at$, the above equation becomes

$$s = \frac{1}{2} \times at \times t + ut$$

by rearranging, the above equation, we get

$$s = ut + \frac{1}{2}at^2$$

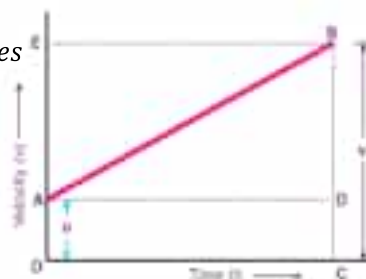

Fig: 2.23

Derivation of Third Equation of Motion by Graphical Method

From the fig: 2.24, we can say that The total distance travelled, s is given by the Area of trapezium OABC.

Hence,

$$S = \frac{1}{2} (\text{Sum of Parallel Sides}) \times \text{Height}$$

$$S = \frac{1}{2} (OA + CB) \times OC$$

Since, $OA = u$, $CB = v$, and $OC = t$

The above equation becomes

$$S = \frac{1}{2} (u + v) \times t$$

Now, since $t = (v - u) / a$

The above equation can be written as:

$$S = \frac{1}{2} ((u + v) \times (v - u)) / a$$

Rearranging the equation, we get

$$S = \frac{1}{2} (v + u) \times (v - u) / a$$

$$S = (v^2 - u^2) / 2a$$

Third equation of motion is obtained by solving the above equation:

$$v^2 = u^2 + 2aS$$

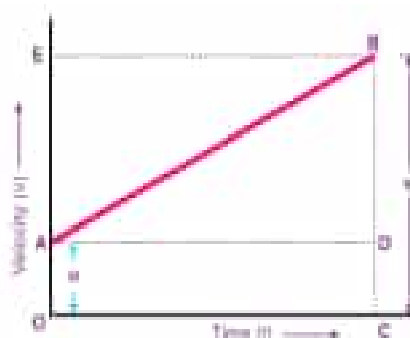

Fig: 2.24

Self-Assessment Questions:

1. If the displacement-time graph is a straight line, what does it indicate about the object's motion?
2. What does the area under a velocity-time graph represent?

Worked Example 2.3

A Car with an initial velocity of 1 m/sec was in motion for 10 minutes, and then it came to a rest, the velocity right before it stopped was 5 m/sec. What was the constant acceleration of the car?

Solution:

Step 1: Write the known quantities and point out quantities to be found.

Initial Velocity = 1 m/sec

Final Velocity = 5 m/sec

Time for which the car was in motion = 10 mint

Acceleration = ?

Step 2: Write the formula and rearrange if necessary

Using First equation of motion,

$$v = u + at$$

Step 3: Put the value in formula and calculate

$$5 = 1 + a \times (10 \times 60)$$

$$a \times 600 = 4$$

$$a = 4/600$$

$$a = 0.0066 \text{ m/sec}^2$$

Worked Example 2.4

A cycle covered 2 km in 8 minutes and the initial velocity of the cycle was 1 m/sec. Find the acceleration that the cycle had in its motion.

Solution:

Step 1: Write the known quantities and point out quantities to be found.

Displacement covered = 2km

Total Time Taken = 8minutes = $8 \times 60 = 480$ seconds.

Initial Velocity = 1 m/sec

Using Second equation of motion to find the acceleration of the cycle,

Step 2: Write the formula and rearrange if necessary

Second Equation of motion, $S = ut + \frac{1}{2}(at^2)$

Step 3: Put the value in formula and calculate

$$2000 = 1 \times 480 + \frac{1}{2}(a \times 480^2)$$

$$2000 = 480 + 115200a$$

$$1520 = 115200a$$

$$a = 0.0139 \text{ m/sec}^2$$

Projectile Motion:

In this universe we see different objects motion in different dimensions, some are moving along a linear path, like a car travelling along a rectilinear path and some are moving along a circular path/track. If a cricketer hits a ball, this ball will follow a curved path and will hit the ground, also if a missile is fired then it follows a curved path which are the examples of two dimensional motion. In this section we will be able to know the answers of these questions that what affects the motion of bodies which is responsible for the curved Path motion of bodies.

Projectile motion:

- The motion of an object in a plane under the influence of force of gravity of earth.
- Gravitational force of earth is responsible for the Projectile motion and the curved path followed by a projectile is called its trajectory.

Assumptions for projectile motion:

It is easy to analyze the projectile motion if following assumptions are in consider:

- 1. The value of acceleration due to gravity is considered as constant throughout the projectile motion and it is always directed downwards.
- 2. The effect of air resistance is negligible.
- 3. Projectile motion is not affected due to rotation of an earth.

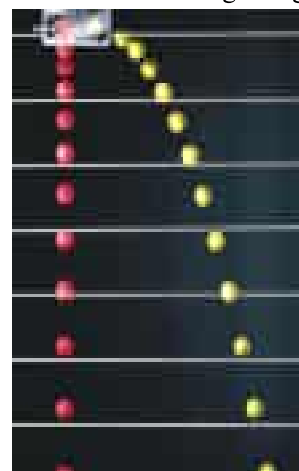

Projectile Motion Fig: 2.25

Average velocity vector:

The red ball is dropped at the same time that the yellow ball is fired horizontally as shown in fig: 2.25. Photos are separated by equal time intervals, Δt . At any time the two balls have the same: y . The yellow ball has equal Δx , and v_x during each time Δt . Projectile motion is analyzed to two motions: horizontal motion with constant velocity and vertical motion with constant acceleration

The x and y motion in projectile motion:

The motion of body in x, y plane is shown in fig: 2.26

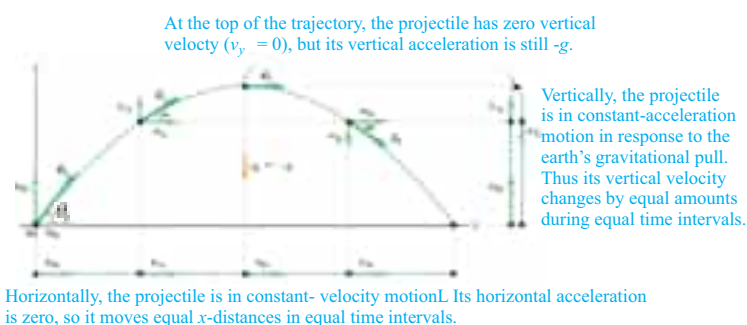

Fig: 2.26

$ax = 0$	$ay = -g$
Horizontal	Vertical
$v_x = v_{0x} + a_x t$	$v_y = v_{0y} + a_y t$
$x - x_0 = v_{0x} t + \frac{1}{2} a_x t^2$	$y - y_0 = v_{0y} t + \frac{1}{2} a_y t^2$
$v_x^2 = v_{0x}^2 + 2a_x(x - x_0)$	$v_y^2 = v_{0y}^2 + 2a_y(y - y_0)$

v_{0x} is constant. $v_{0x} = v_0 \cos \theta_0 \dots\dots(2.16)$

v_{0y} changes continuously. $v_{0y} = v_0 \sin \theta_0 \dots\dots(2.17)$

After considering all the conditions the Equations will be

$$v_x = v_{0x} \qquad v_y = v_{0y} - gt$$

$$x = x_0 + v_{0x} t \qquad y = y_0 + v_{0y} t - \frac{1}{2} gt^2$$

Time taken by projectile to reach the maximum height:

If we consider t is the time required to achieve the maximum height by a projectile then it can be found by using 1st equation of motion.

$$V_{fy} = V_{iy} + a_y t$$

$$0 = V_0 \sin \theta - gt$$

$$V_0 \sin \theta = gt$$

$$t = \frac{V_0 \sin \theta}{g}$$

Total time of flight of projectile:

The time during which projectile remains in air is called its “Total time of flight” (T). from the definition we know that total time of flight should be the sum of time requires to reach maximum height t_h and time required to hit back the ground t_g . So therefor

$$T = t_h + t_g$$

$$T = 2t$$

Thus $T = \frac{2V_0 \sin \theta}{g} \dots\dots\dots(2.18)$

$\therefore t_h = t_g = t$ $\therefore t = \frac{V_0 \sin \theta}{g}$

Unit 2: Kinematics

Maximum height reached by the projectile:

The maximum vertical distance covered by the projectile is called maximum height. It is denoted by 'H' the maximum height reached by the projectile can be found by using formula:

$$Y = V_{iy} t + \frac{1}{2} a_y t^2$$

$$H = V_o \sin \theta \left(\frac{V_o \sin \theta}{g} \right) + \frac{1}{2} (-g) \left(\frac{V_o \sin \theta}{g} \right)^2$$

$$H = \frac{v_o^2 \sin^2 \theta}{g} - \frac{v_o^2 \sin^2 \theta}{2g}$$

$$H = \frac{v_o^2 \sin^2 \theta}{2g} \dots\dots(2.19)$$

$$\therefore V_{iy} = V_{oy} = V_o \sin \theta$$

$$\therefore t = \frac{V_o \sin \theta}{g}$$

$$\therefore a_y = -g$$

Range of the projectile:

The horizontal distance covered by the projectile between point of projection and point of return to level of projection is called Range of the projectile and is represented by 'R' and can be found by formula.

$$X = V_{ox} T$$

Let's consider $X = R$; $V_{ox} = V_o \cos \theta$

$$\text{and } T = \frac{2V_o \sin \theta}{g}$$

After putting all these values Now

$$R = V_o \cos \theta \left(\frac{2V_o \sin \theta}{g} \right)$$

$$R = v_o^2 \left(\frac{2 \sin \theta \cos \theta}{g} \right) \quad \therefore 2 \sin \theta \cos \theta = \sin 2\theta$$

$$R = \frac{v_o^2 \sin 2\theta}{g} \dots\dots(2.20)$$

Projectile Motion at Various Initial Angles:

From the mathematical relation of range we observe that V_o and g are constants, so maximum range of the projectile can be achieved only when $\sin 2\theta$ becomes maximum ($\sin 2\theta = 1$). as we know that $\sin 90^\circ = 1$; this relation shows that the maximum range can be achieved only projectile will be launched at angle of 45° .

Taking $R = R_{max}$ and $\theta = 45^\circ$

$$R_{max} = \frac{v_0^2 \sin 2(45^\circ)}{g}$$

$$R_{max} = \frac{v_0^2 \sin 90^\circ}{g}$$

$$R_{max} = \frac{V_0^2}{g} \dots\dots(2.21)$$

Thus for the maximum horizontal range, the angle of projectile should be 45°. Complementary values of the initial angle result in the same range

- The heights will be different. The maximum range occurs at a projection angle of 45°

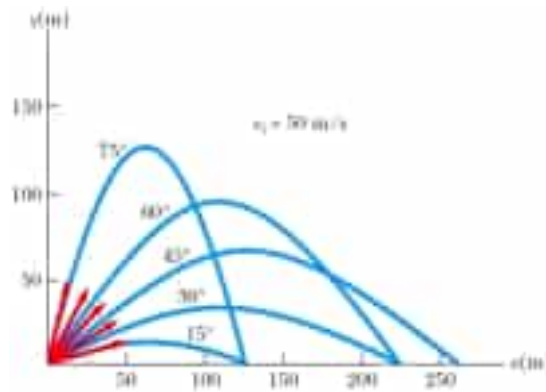

Fig: 2.27 range covered at different angles

The range of different projected bodies at different angle is shown in fig:2.27.

Self-Assessment Questions

1. When an object is projected horizontally, how does its vertical velocity change over time?
2. Can the range of a projectile be increased by increasing its initial velocity? Explain your answer.

Worked Example 2.5

A body is projected with a velocity of 20ms⁻¹ at the angle of 50 degree to the horizontal plane. Find the time of flight of the projectile.

Solution:

Step 1: Write the known quantities and point out quantities to be found.

Initial Velocity $V_0 = 20\text{ms}^{-1}$

angle $\theta = 50^\circ$

$g = 9.8\text{ms}^{-2}$

Step 2: Write the formula and rearrange if necessary

Formula for time of flight is,

$$T = \frac{2V_0 \sin \theta}{g}$$

Step 3: Put the value in formula and calculate

$$T = 2 \times 20 \times \sin 50^\circ / 9.8$$

$$T = 2 \times 20 \times 0.766 / 9.8$$

$$T = 30.64 / 9.8$$

$$T = 3.126 \text{ sec}$$

Therefore time of flight is 3.126 second.

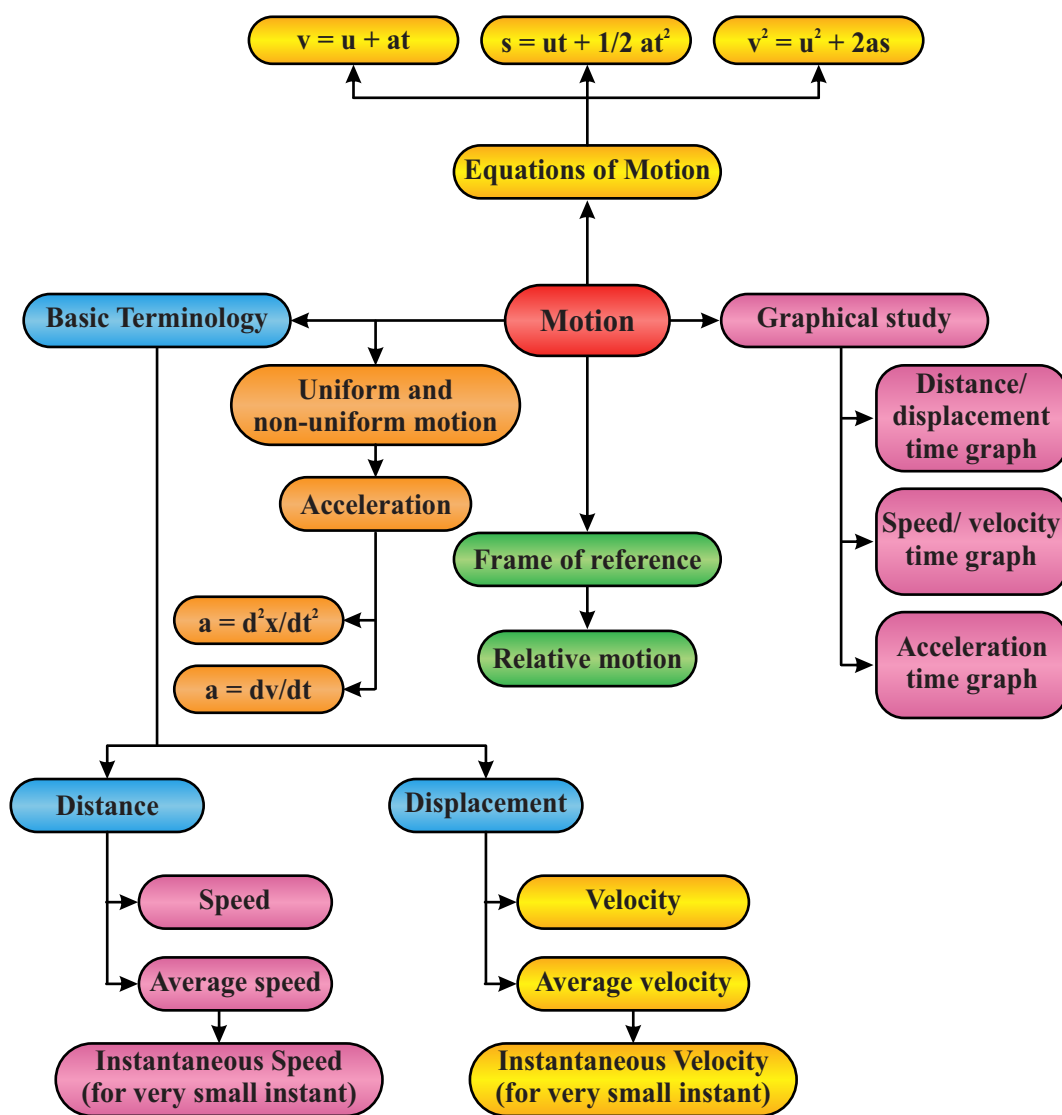



SUMMARY

- Study of motion without considering the forces involved is called Kinematics.
- Location of an object in space or co-ordinates system is known as Position.
- Change in position of an object in particular direction is called Displacement.
- Total path traveled by an object is called Distance.
- Magnitude of the velocity vector; how fast an object moves is known as Speed.
- Velocity is the Rate of change of displacement.
- Rate of change of velocity; can be positive or negative is called Acceleration.
- Uniform Motion is the Constant speed and direction.
- Changing speed or direction is known as Non-Uniform Motion.
- Velocity of an object at a specific moment in time is known as Instantaneous Velocity.
- Average Velocity is the total displacement divided by the total time.
- Equations of Motion are the Mathematical expressions linking displacement, velocity, acceleration, and time for uniform and constant acceleration motion.

$$V_f = V_i + at$$

$$V_f^2 = V_i^2 + 2as$$

$$S = V_i t + \frac{1}{2}at^2$$

- Deceleration is the negative acceleration; the object slows down.
- Retardation is also known as deceleration.
- Motion under the influence of gravity alone, with no other forces acting on the object is known as Free Fall.
- Projectile Motion is the motion of an object under the influence of gravity, moving horizontally and vertically.
- Time of flight is the total time taken by a projectile to reach the ground.
- Horizontal distance covered by a projectile is known as Range.
- The maximum range of projectile can be obtained at the angle of 45°.



EXERCISE

Section (A): Multiple Choice Questions (MCQs)

- To get a resultant displacement of 10m, two displacement vectors of magnitude 6m and 8m should be combined:
(a) Parallel (b) Antiparallel
(c) At an angle of 45° (d) Perpendicular to each other
- The velocity of a particle at an instant is 10 m/s and after 5sec the velocity of particle is 20m/s. The velocity at 3 sec before in before 10m/s is:
(a) 8 (b) 4
(c) 6 (d) 7
- A ball is thrown upwards with a velocity of 100 m/s. It will reach the ground after:
(a) 10 sec (b) 20 sec
(c) 5 sec (d) 40 sec
- Two projectiles are fired from the same point with the same speed at angles of projection 60° and 30° respectively. Which one of the following is true?
(a) The range will be same (b) Their maximum height will be same
(c) Their landing velocity will be same (d) their time of flight will be same
- The ratio of numerical values of average velocity and average speed of a body is always:
(a) Unity (b) Unity or less
(c) Unity or more (d) Less than unity
- If the average velocities of a body become equal to the instantaneous velocity, body is said to be moving with:
(a) Uniform acceleration (b) Uniform velocity
(c) Variable velocity (d) Variable acceleration
- At the top of a trajectory of a projectile, the acceleration is:
(a) maximum (b) minimum
(c) zero (d) g
- At what angle the range of projectile becomes equal to the height of projectile?
(a) 65° (b) 45
(c) 76° (d) 30°
- The angle at which dot product becomes equal to the cross product is:
(a) 65° (b) 45°
(c) 76° (d) 30°
- If the dot product of two non-zero vectors vanishes; the vectors will be:
(a) in the same direction (b) opposite direction to each other
(c) perpendicular to each other (d) zero

CRQs:

1. Is the range equivalent to the horizontal distance in the projectile motion, or do they have distinct meaning? Explain
2. If air resistance is taken into account in case of projectile motion, then what parameters of projectile are influenced?
3. What are some real-life examples of projectile motion? Can motion of an aero plane be considered as projectile motion? Explain
4. Where do we use the concept of speed and velocity in our daily life? Can you give some examples?
5. Can an object have an initial velocity of zero and still experience uniformly accelerated motion

ERQs:

1. What are three equations of uniformly accelerated motion and how they are derived?
2. How does the horizontal component of velocity in projectile motion behaves?
3. What is the significance of the area under a velocity-time graph in the context of accelerated motion?
4. How do the initial launch angle and velocity affect projectile motion?
5. Explain the concept of independence between horizontal and vertical motion in projectile motion

Numericals:

1. A helicopter is ascending at the rate of 12 m/s. At a height of 80 m above the ground, a package is dropped. How long does the package take to reach the ground?
(Ans: 5.4 sec)
2. Two tug boats are towing a ship each exerts a force of 6000 N, and the angle between two ropes is 60° . Calculate the resultant force on the ship? (Ans: 10392 N)
3. A car starts from rest and moves with a constant acceleration. During the 5th second of its motion, it covers a distance of 36 meters. Calculate:
(a) acceleration of the car
(b) the total distance covered by the car during this time. (Ans: 8m/s^2 , 100 m)
4. Show that the range of projectile at complementary angles are same with examples?
5. At what angle the range of projectile becomes equal to the height of projectile?
(Ans: 76°)
6. A marter shell is fired at a ground level target 500 m distance with an initial velocity of 90 m/s. What is the launch angle?
(Ans: 71.4°)

Unit

3

Dynamics

Teaching Periods 9

Weightage % 6



Pride of Pakistan, Arshad Nadeem, the first South Asian to cross the 90 meter barrier in Birmingham as he clinched the gold medal, breaking the commonwealth games record in Javelin throw

In this unit student should be able to:

- Apply Newton's laws to explain motion of objects
- Define inertia (as the property of a body which resists change in motion).
- Describe and use of the concept of weight as the effect of a gravitational field on a mass.
- Apply Newton's laws of motion
- Describe the Collision, Momentum and Impulse
- Relation between Newton's 2nd law and Linear Momentum
- Explain law of conservation of Momentum
- Describe elastic and inelastic collision with examples
- Solve different problems of elastic and inelastic collisions between two bodies in one dimension by using law of conservation of momentum.
- Describe that momentum is conserved in all situations. (Rocket Situation)

Dynamics is also the branch of mechanics in which we study about the motion with reference of force. In this chapter students will be able to learn the behavior of force, how it plays its role to change the state (rest or motion) of body.

Newton's Laws of Motion

Sir Isaac Newton's laws of motion explain the relationship between a physical object and the forces acting upon it. Understanding this information provides us with the basis of modern physics.

Newton's first law: Inertia

Newton's first law states that every object will remain at rest or in uniform motion in a straight line unless compelled to change its state by the action of an external force. This tendency to resist changes in a state of motion is inertia. There is no net force acting on an object (if all the external forces cancel each other out). Then the object will maintain a constant velocity. If that velocity is zero, then the object remains at rest. If an external force acts on an object, the velocity will change because of the force.

The first law of motion is also known as the law of inertia.

Inertia

The property by virtue of which a body opposes any change in its state of rest or of uniform motion is known as inertia. Greater the mass of the body greater will be its and vice-versa inertia. Mass is direct measure of its inertia.

Numerical Application If, $F = 0$; $a = 0$; $v = \text{constant}$ (In the absence of external applied force velocity of body remains unchanged.)

Physical Application of inertia or newton's first law

1. When a moving car suddenly stops, passenger's head gets pulled in the forward direction to prevent this action driver fasten seat belts.
2. When we hitting used mattress by a stick, dust particles come out of it.
3. In order to catch a moving bus safely we must run forward in the direction of motion of bus.
4. Whenever it is required to jump off a moving bus, we must always run for a short distance after jumping on road to prevent us from falling in the forward direction.

DO YOU KNOW?

External Force?

An external force is defined as the change in the mechanical energy that is either the kinetic energy or the potential energy in an object.

These forces are caused by external agents. Examples of external forces are friction, normal force and air resistance.

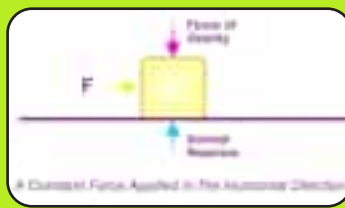

DO YOU KNOW?

Acceleration: a measurement of how quickly an object is changing speed.

Net force (F_{net}): The sum total and direction of all forces acting on the object.

Newton's Second Law: Force

Forces can be balanced or unbalanced. An *unbalanced force* causes something to accelerate. It depends on the **net force** acting on the object that **always causes acceleration**.

The acceleration of an object depends on the mass of the object and the amount of force applied.

Acceleration of an object is directly proportional to the applied force

$$a \propto F \quad (1)$$

Acceleration of an object is inversely proportional to the mass of an object

$$a \propto 1/m \quad (2)$$

By combining both equations (1) & (2)

$$a \propto k \frac{F}{m} \quad \therefore k = 1$$

$$a = F/m$$

$$F = ma \dots\dots(3.1)$$

DO YOU KNOW?

If you *double* the mass, you *double* the force. If you *double* the acceleration, you *double* the force.

What if you double the mass *and* the acceleration?

$$(2m)(2a) = 4F$$

Doubling the mass *and* the acceleration *quadruples* the force.

Worked Example 3.1

A 50 N force applied on a box of mass 8.16 kg to move on the right across a horizontal surface. What is the acceleration of produced in the box.

Solution:

Step 1: Write the known quantities and point out quantities to be found.

$$\vec{F} = 50 \text{ N}$$

$$m = 8.16 \text{ kg}$$

$$a = ?$$

Step 2: Write the formula and rearrange if necessary

$$\vec{F} = ma \text{ or } a = \frac{\vec{F}}{m}$$

Step 3: Put the value in formula and calculate

$$a = \frac{\vec{F}}{m}$$

$$a = \frac{50}{8.16}$$

$$a = 6.13 \text{ ms}^{-2}$$

The acceleration of the box is found to be 6.13ms⁻².

Newton's Third Law: Action & Reaction

Whenever one object exerts a force on a second object, the second object exerts an equal and opposite force on the first. His third law states that for every **action** (force) there is an equal and opposite **reaction**. If object A exerts a force on object B, object B also exerts an equal and opposite force on object A as shown in fig: 3.1.

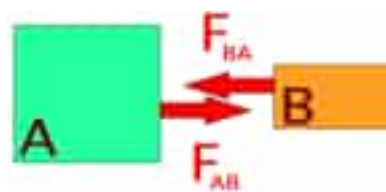

Fig: 3.1

In other words, forces result from interactions.

For every force acting on an object, there is equal force acting in the opposite direction. Right now, gravity is pulling you *down* in your seat, but Newton's Third Law says your seat is pushing *up* against you with *equal force*. This is why you are not moving. There is balanced *force* acting on you– gravity pulling down, your seat pushing up.

Examples

- The motion of lift from an airfoil, the air is deflected downward by the airfoil's action, and in reaction, the wing is pushed upward.
- The motion of a spinning ball, the air is deflected to one side, and the ball reacts by moving in the opposite
- The motion of a **jet engine** produces thrust and hot exhaust gases flow out the back of the engine, and a thrusting force is produced in the opposite direction.

Self-Assessment Questions:

- Suppose that the acceleration of an object is zero. Does this mean that there are no forces acting on it?
- Can objects with different masses experience the same magnitude of force when they interact? Why or why not?

3.2 Momentum and impulse

3.2.1 Momentum, Impulse, and Collisions

Consider A moving van collides head-on with a compact car. What determined which way the wreckage moves after the collision?

How do you decide how to knock the billiard balls?

We cannot use Newton's second law to solve such problems because we know very little about the complicated forces involved.

To solve such problems: We introduce **momentum** and **impulse**, and the **conservation of momentum**.

Momentum and Impulse

Physical quantity that describes the quantity of motion in a body is called momentum.

The momentum of a moving body is defined as

“the product of mass and velocity of a moving body is called linear momentum”

$$\vec{p} = m\vec{v} \quad \dots\dots(3.2)$$

Momentum is a vector quantity and its direction is the same as that of velocity.as shown in figure 3.2

DO YOU KNOW?

Newton's 3rd: describes the relationship between two forces in an interaction.

One force is called the **action force**.

The other force is called the **reaction force**.

Neither force exists without the other.

They are equal in strength and opposite in direction.

They occur at the same time (simultaneously).

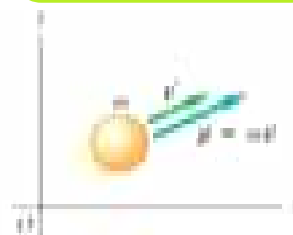
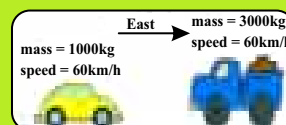

Momentum p is a vector quantity

Fig: 3.2

Explanation

Momentum is that property of a moving body which determines how much effort is required to accelerate or stop a body. Hence, it may also be termed as quantity of motion of a body. From various observations it is concluded that greater effort is required to stop a body if it possesses either greater mass or greater velocity or both.

Units Of Momentum

In S.I. system: Ns [1 Ns = 1 kg m/s]

In C.G.S. system: dyne.S

In F.P.S. system: lb.s

Dimensions of Momentum

The dimension of momentum is [MLT⁻¹].

Newton 2nd Law and Linear Momentum

Newton's Second Law can be used to relate the momentum of an object to the resultant force acting on it

$$\sum \vec{F} = m\vec{a} = m \frac{d\vec{v}}{dt} \text{ OR}$$

Newton's second law can be written in terms of momentum as

Keeping mass as constant

$$\sum \vec{F} = \frac{d\vec{p}}{dt} \dots\dots(3.3)$$

The change in an object's momentum divided by the elapsed time equals the constant net force acting on the object

$$\frac{\Delta\vec{p}}{\Delta t} = \frac{\text{change in momentum}}{\text{time interval}} = \vec{F}_{net}$$

Impulse

Consider A tennis ball is in contact with the rickets which exerts the force of magnitude \vec{F} on tennis ball for very short time Δt as shown in the fig: 3.3.



Fig: 3.3 (Impulse)

Definition: The impulse of a force \vec{J} is the product of the force and the time interval Δt during which it acts.

$$\vec{J} = \sum \vec{F} \Delta t \dots\dots (3.4)$$

$$\vec{J} = \vec{F} \Delta t = \Delta\vec{P}$$

$$\vec{J} = \Delta\vec{P} \dots\dots(3.5)$$

Self-Assessment Questions:

1. How is impulse related to the change in momentum of an object?
2. An object with an initial momentum of 50 kg m/s experiences an impulse of 100 Ns. Calculate its final momentum.
3. A golf club exerts an average force of 800 N on a golf ball for 0.02 seconds. If the initial velocity of the ball is 40 m/s and its final velocity is 60 m/s, what is the impulse experienced by the ball?

Worked Example 3.2

A hockey puck with a mass of 0.2 kg is sliding on the ice at a velocity of 10 m/s. It collides with a wall and bounces back with a velocity of -8 m/s. The collision lasts for 0.1 seconds. Calculate the impulse experienced by the hockey puck and the change in its momentum.

Solution:

Step 1: Calculate the initial momentum (p_{initial}) of the hockey puck before the collision:

$$p_{\text{initial}} = \text{mass} \times \text{initial velocity}$$

$$p_{\text{initial}} = 0.2 \text{ kg} \times 10 \text{ m/s} = 2 \text{ kg}\cdot\text{m/s}$$

Step 2: Calculate the final momentum (p_{final}) of the hockey puck after the collision:

$$p_{\text{final}} = \text{mass} \times \text{final velocity}$$

$$p_{\text{final}} = 0.2 \text{ kg} \times (-8 \text{ m/s}) = -1.6 \text{ kg}\cdot\text{m/s}$$

Step 3: Calculate the change in momentum (Δp):

$$\Delta p = p_{\text{final}} - p_{\text{initial}}$$

$$\Delta p = (-1.6 \text{ kg}\cdot\text{m/s}) - (2 \text{ kg}\cdot\text{m/s}) = -3.6 \text{ kg}\cdot\text{m/s}$$

Step 4: Calculate the impulse (J) experienced by the hockey puck during the collision:

$$J = \Delta p$$

$$J = -3.6 \text{ kg}\cdot\text{m/s}$$

The impulse experienced by the hockey puck during the collision is -3.6 kg·m/s, and the change in its momentum is also 3.6 kg·m/s.

DO YOU KNOW?**Compare momentum and kinetic energy**

Changes in momentum depend on the time over which the net force acts, and it is a vector quantity. Changes in kinetic energy depend on the distance over which the net force acts, and it is a scalar quantity.

(Note: If the derivative of any quantity is zero, it must be a constant quantity.)

Law of Conservation of Linear Momentum

The **law of conservation of linear momentum** states that if no external forces act on the system of two colliding objects, then the vector sum of the linear momentum of each body remains constant and is not affected by their mutual interaction.

Alternatively, it states that if net external force acting on a system is zero, the total momentum of the system remains constant.

Proof:

Let us consider a particle of mass 'm' and acceleration 'a'. Then, from 2nd law of motion,

$$F = \frac{dP}{dt}$$

If no external force acts on the body then, $F=0$,

$$F = \frac{dP}{dt} = 0 \dots \dots (3.6)$$

In result **P** remains constant or conserved.

Law of Conservation of linear momentum for two colliding bodies

Let us consider two objects of masses m_1 and m_2 moving in straight line with initial velocities u_1 and u_2 as shown in figure 3.4(a). When two objects collide, they experience equal and opposite forces on each other for short time Δt as shown in figure 3.4(b). These forces cause a change in the momentum of the objects. After collision, objects moves in the same direction but with different velocities v_1 and v_2 respectively as shown in fig: 3.4(c).

At the time of collision m_1 exerts force on m_2 is F_{12}

$$F_{12} = (m_2v_2 - m_2u_2)/\Delta t$$

in reaction m_2 exerts force on m_1 which is F_{21}

$$F_{21} = (m_1v_1 - m_1u_1)/\Delta t$$

As per statement of Newton's 3rd law

$$F_{12} = -F_{21} \dots\dots(3.7)$$

$$(m_2v_2 - m_2u_2)/\Delta t = -(m_1v_1 - m_1u_1)/\Delta t$$

$$m_1v_1 + m_2v_2 = m_1u_1 + m_2u_2 \dots\dots(3.8)$$

Above equation shows that in the absence of an external force the total momentum before collision is equals to total momentum after collision or in other words total momentum remains conserved during the collision.

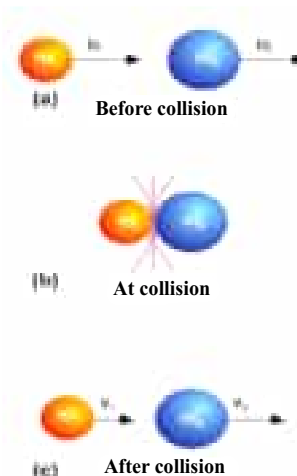

Fig: 3.4

Elastic and Inelastic Collision

Elastic Collision

An elastic collision is that in which the momentum of the system as well as kinetic energy of the system before and after collision is conserved.

Inelastic Collision

An inelastic collision is that in which the momentum of the system before and after collision is conserved but the kinetic energy before and after collision is not conserved.

Elastic Collision in One Dimension

Consider two non-rotating spheres of mass m_1 and m_2 moving initially along the line joining their centers with velocities u_1 and u_2 in the same direction. Let u_1 is greater than u_2 . They collide with one another and after having an elastic collision start moving with velocities v_1 and v_2 in the same directions on the same line as shown in fig:3.5.

Momentum of the system before collision = $m_1u_1 + m_2u_2$

Momentum of the system after collision = $m_1v_1 + m_2v_2$

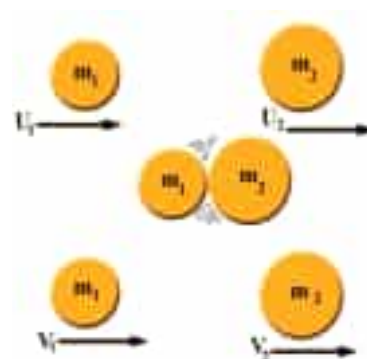

Fig: 3.5

According to the law of conservation of momentum:

$$\begin{aligned} m_1 u_1 + m_2 u_2 &= m_1 v_1 + m_2 v_2 \\ m_1 v_1 - m_1 u_1 &= m_2 u_2 - m_2 v_2 \\ m_1 (v_1 - u_1) &= m_2 (u_2 - v_2) \dots\dots (3.9) \end{aligned}$$

Similarly

$$\text{K.E of the system before collision} = \frac{1}{2} m_1 u_1^2 + \frac{1}{2} m_2 u_2^2$$

$$\text{K.E of the system after collision} = \frac{1}{2} m_1 v_1^2 + \frac{1}{2} m_2 v_2^2$$

Since the collision is elastic, so the K.E of the system before and after collision is conserved.

Thus

$$\begin{aligned} \frac{1}{2} m_1 v_1^2 + \frac{1}{2} m_2 v_2^2 &= \frac{1}{2} m_1 u_1^2 + \frac{1}{2} m_2 u_2^2 \\ \frac{1}{2} (m_1 v_1^2 + m_2 v_2^2) &= \frac{1}{2} (m_1 u_1^2 + m_2 u_2^2) \\ m_1 v_1^2 - m_1 u_1^2 &= m_2 u_2^2 - m_2 v_2^2 \\ m_1 (v_1^2 - u_1^2) &= m_2 (u_2^2 - v_2^2) \\ m_1 (v_1 + u_1) (v_1 - u_1) &= m_2 (u_2 + v_2) (u_2 - v_2) \dots\dots (3.10) \end{aligned}$$

Dividing equation (3.10) by equation (3.9)

$$\frac{m_1 (v_1 + u_1) (v_1 - u_1)}{m_1 (v_1 - u_1)} = \frac{m_2 (u_2 + v_2) (u_2 - v_2)}{m_2 (u_2 - v_2)}$$

$$v_1 + u_1 = u_2 + v_2$$

From the above equation

$$v_1 = u_2 + v_2 - u_1 \dots\dots (i)$$

$$v_2 = v_1 + u_1 - u_2 \dots\dots (ii)$$

Putting the value of v_2 in equation (3.9)

$$\begin{aligned} m_1 (v_1 - u_1) &= m_2 (u_2 - v_2) \\ m_1 (v_1 - u_1) &= m_2 \{u_2 - (v_1 + u_1 - u_2)\} \\ m_1 (v_1 - u_1) &= m_2 \{u_2 - v_1 - u_1 + u_2\} \\ m_1 (v_1 - u_1) &= m_2 \{2u_2 - v_1 - u_1\} \\ m_1 v_1 - m_1 u_1 &= 2m_2 u_2 - m_2 v_1 - m_2 u_1 \\ m_1 v_1 + m_2 v_1 &= m_1 u_1 - m_2 u_1 + 2m_2 u_2 \\ v_1 (m_1 + m_2) &= (m_1 - m_2) u_1 + 2m_2 u_2 \end{aligned}$$

$$V_1 = \frac{(m_1 - m_2) u_1}{(m_1 + m_2)} + \frac{2m_2 u_2}{(m_1 + m_2)} \dots\dots (3.11)$$

In order to obtain V_2 putting the value of V_1 from equation (i) in equation (3.9)

$$\begin{aligned} m_1 (v_1 - u_1) &= m_2 (u_2 - v_2) \\ m_1 (u_2 + v_2 - u_1 - u_1) &= m_2 (u_2 - v_2) \\ m_1 (u_2 + v_2 - 2u_1) &= m_2 (u_2 - v_2) \\ m_1 u_2 + m_1 v_2 - 2m_1 u_1 &= m_2 u_2 - m_2 v_2 \\ m_1 v_2 + m_2 v_2 &= 2m_1 u_1 + m_2 u_2 - m_1 u_2 \\ v_2 (m_1 + m_2) &= 2m_1 u_1 + (m_2 - m_1) u_2 \end{aligned}$$

$$V_2 = \frac{2m_1 u_1 + (m_2 - m_1) u_2}{(m_1 + m_2)} \dots\dots (3.12)$$

Self-Assessment Questions:

1. How does kinetic energy change in an elastic collision? Why?
2. What happens to the objects involved in an inelastic collision after the collision?

Worked Example 3.3

Two objects, A and B, are initially at rest on a frictionless surface. Object A has a mass of 0.5 kg, and object B has a mass of 0.8 kg. Object A collides with object B. After the collision, object A moves to the right at a velocity of 4 m/s, and object B moves to the left at a velocity of 2 m/s.

- a) Calculate the total momentum before the collision.
- b) Calculate the total momentum after the collision.
- c) Calculate the kinetic energy before and after the collision.

Step 1: a) Total momentum before the collision:

Step 2: Initial momentum of both objects is zero since they are at rest. Therefore, the total momentum before the collision is 0 kg·m/s.

Step 3: b) Total momentum after the collision:

Total momentum after the collision is the sum of the momenta of objects A and B:

$$P_A = m_A \times v_A = 0.5 \text{ kg} \times 4 \text{ m/s} = 2 \text{ kg} \cdot \text{m/s} \text{ (to the right)}$$

$$P_B = m_B \times v_B = 0.8 \text{ kg} \times (-2 \text{ m/s}) = -1.6 \text{ kg} \cdot \text{m/s} \text{ (to the left)}$$

$$\text{Total momentum after the collision: } 2 \text{ kg} \cdot \text{m/s} - 1.6 \text{ kg} \cdot \text{m/s} = 0.4 \text{ kg} \cdot \text{m/s} \text{ (to the right)}$$

Step 4: c) Kinetic energy before the collision:

Both objects are initially at rest, so the initial kinetic energy is zero.

Step 5: d) Kinetic energy after the collision:

Kinetic energy after the collision for object A:

$$K \cdot E_A = (1/2) \times m_A \times v_A^2 = (1/2) \times 0.5 \text{ kg} \times (4 \text{ m/s})^2 = 4 \text{ J}$$

Kinetic energy after the collision for object B:

$$K \cdot E_B = (1/2) \times m_B \times v_B^2 = (1/2) \times 0.8 \text{ kg} \times (-2 \text{ m/s})^2 = 1.6 \text{ J}$$

$$\text{Total kinetic energy after the collision: } 4 \text{ J} + 1.6 \text{ J} = 5.6 \text{ J}$$

Friction

When a solid object moves or attempts to move over the surface of another solid object as shown in fig:3.6. its motion is always opposed by a retarding force. This force is called friction. Thus, friction is the force directed opposite to the direction of motion or attempted motion. The frictional force is always parallel to the surface in contact.

The friction and normal forces are really components of a single contact force

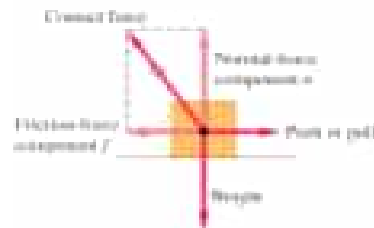

Fig: 3.6

Origin of Friction

Classical view

According to Classical view, when two objects are kept in contact, there forms an interlock between the irregular surfaces and to break the interlock, we need an extra force. This force measures the force of friction.

Modern view

According to modern theory, friction is due to intermolecular force of attraction between the surfaces in contact. When two surfaces are put together, the actual area of contact is very less than the apparent area of contact. The pressures at the contact points are very high and the molecules are pushed very close so that attractive forces between them weld the surfaces together at contact points (which is called cold welding). To break this attachment we need an extra force as shown in fig:3.7.

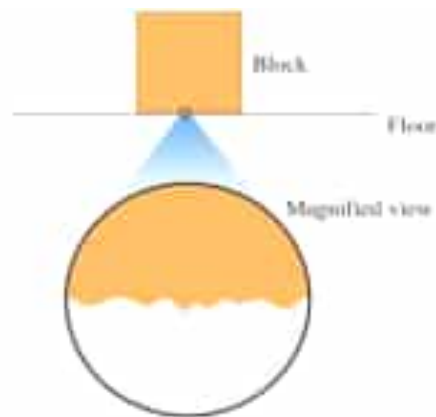

On a microscopic level, even smooth surfaces are rough; they tend to catch and cling

Fig: 3.7

Types of Friction

Static Friction

The friction force that comes into play between the two surfaces when one body tends to move on the surface of other body is called static friction.

$$f_s \leq \mu_s N$$

The maximum value of static friction is called limiting friction.

Kinetic Friction

The frictional force that comes into play between the two surfaces when one body moves on the surface of other body is called kinetic friction.

$$f_k = \mu_k N \dots (3.13)$$

There are two types of kinetic friction. They are:

a) Sliding Friction

The friction that exists between two surfaces when one body is sliding on the other is called sliding friction. For example: friction between the wood block and the road when the wood block slides on the road.

b) Rolling Friction

The friction that exists between two surfaces when one surface is rolling over the other is called rolling friction. For example: friction between the tyre of moving vehicle and the road.

Laws of Friction

- a) The frictional force opposes the relative motion of two surfaces.
- b) The frictional force is parallel to the surfaces in contact.
- c) The frictional force is directly proportional to the normal reaction.
- d) The frictional force is independent of the area of contact.
- e) The frictional force depends upon the nature of the two surfaces in contact and their state of roughness.
- f) The kinetic friction is independent of the relative velocities of the surfaces.

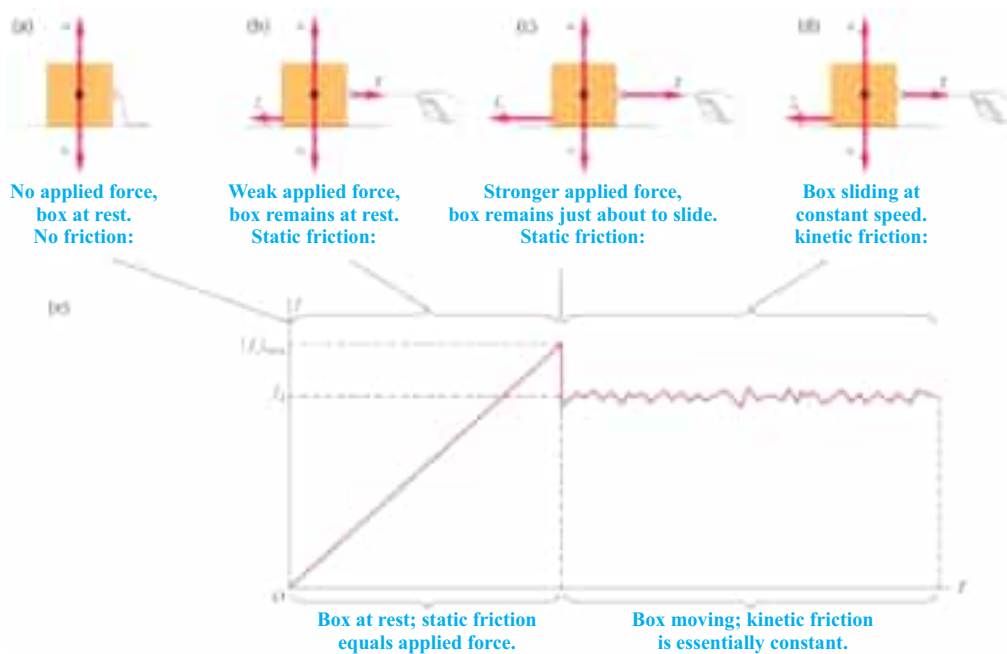

Fig: 3.8

Angle of Friction

Angle of friction is defined as the angle made by the resultant of frictional force and the normal reaction with the normal reaction as shown in fig:3.9.

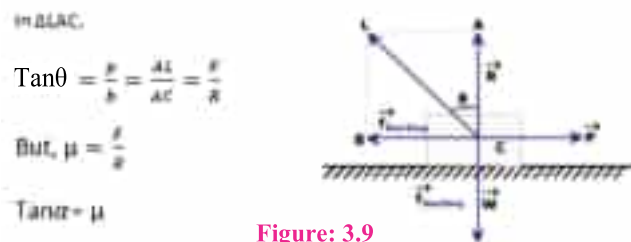

Figure: 3.9

Therefore, tangent of angle of friction is called coefficient of friction.

Relation between Angle of Friction and Angle of Repose

Angle of repose is defined as the minimum angle made by an inclined plane with the horizontal such that an object placed on the inclined surface just begins to slide.

Let us consider a body of mass 'm' resting on a plane.

Also, consider when the plane makes ' θ ' angle with the horizontal, the body just begins to move.

Let ' R ' be the normal reaction of the body and ' f ' be the frictional force.

Here,

$$mg \sin \theta = -f \longrightarrow (i)$$

$$mg \cos \theta = -R \longrightarrow (ii)$$

Dividing equation (i) by (ii)

$$\frac{mg \sin \theta}{mg \cos \theta} = \frac{-f}{-R}$$

$$\tan \theta = \frac{f}{R}$$

Or, $\tan \theta = \mu$, where ' μ ' is the coefficient of friction

Or, $\tan \theta = \tan \alpha$ ($\tan \alpha = \mu$)

where ' α ' is the angle of friction

$\theta = \alpha$

Angle of repose is equal to angle of friction.

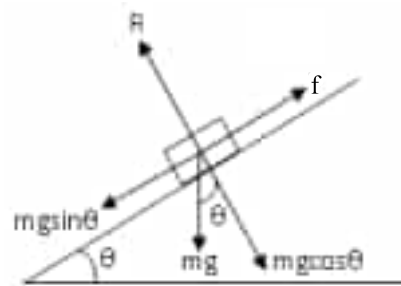
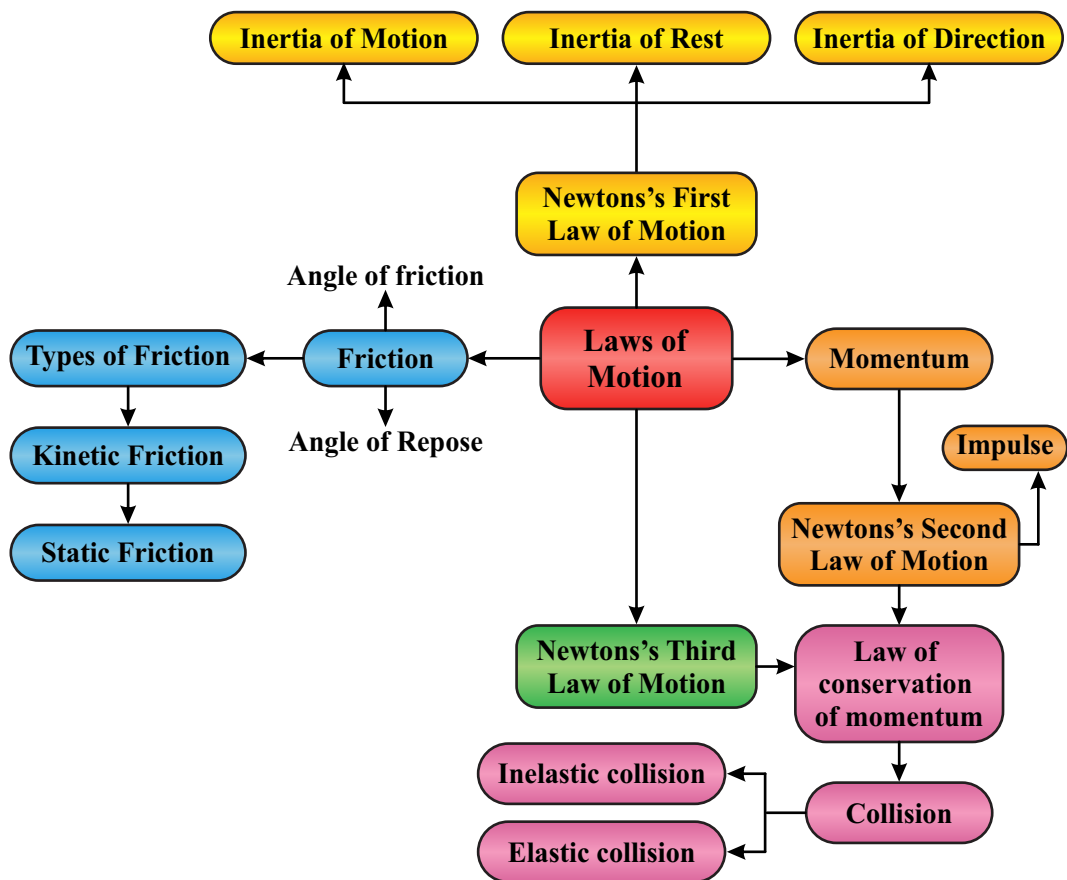

Fig: 3.10





SUMMARY

- Dynamics: Study of the forces and torques that cause motion and the resulting effects.
- Force: Push or pull on an object; causes acceleration.
- Newton's Laws of Motion:
- First Law (Law of Inertia): An object at rest stays at rest, and an object in motion stays in motion unless acted upon by an external force.
- Second Law ($F = ma$): The acceleration of an object is directly proportional to the net force acting on it and inversely proportional to its mass.
- Third Law (Action-Reaction): For every action, there is an equal and opposite reaction.
- Inertia: Resistance of an object to changes its state in its motion due to its mass.
- Friction: Resistance force between two surfaces in contact; opposes relative motion.
- Normal Force: Force exerted by a surface to support the weight of an object in contact with it.
- Momentum: Product of an object's mass and velocity or quantity of motion; conserved in a closed system.
- Impulse: Change in momentum of an object due to an applied force over a time interval.
- Conservation of Momentum: In a closed system, the total momentum before a collision is equal to the total momentum after the collision.
- Elastic Collision: Collisions where both momentum and kinetic energy are conserved.
- Inelastic Collision: Collisions where momentum is conserved, but kinetic energy is not.



EXERCISE

Section (A): Multiple Choice Questions (MCQs)

1. The rate of change of linear momentum of a body is called a:

a) Linear force	b) Angular force
c) Power	d) Impulse
2. The term mass refers to the same physical concept as:

a) weight	b) inertia
c) force	d) acceleration
3. Which one of the following force is also called as self adjusting force ?

a) frictional force	b) tension
c) Weight	d) Thrust
4. The laws of motion shows the relationship between:

a) velocity and acceleration	b) mass and velocity
c) mass and acceleration	d) force and acceleration

Unit 3: Dynamics

5. The motion of rocket in the space is according to the law of conservation of:
a) Energy
b) linear momentum
c) mass
d) angular momentum
6. A bomb of mass 12 kg initially at rest explodes into two pieces of masses 4kg and 8kg . The speed of 8kg mass is 6 m/s. The kinetic energy The kinetic energy of 4 kg mass is:
a) 32 J
b) 48 J
c) 114 J
d) 288 J
7. If momentum is increased by 20% then K.E increases by:
a) 44%
b) 55%
c) 66%
d) 77%
8. The kinetic energy of body of mass 2kg and momentum of 2 Ns is:
a) 1 J
b) 2 J
c) 3 J
d) 4 J
9. For the same kinetic energy, the momentum is maximum for:
a) an electron
b) a proton
c) a deuteron
d) alpha particle
10. A 3kg bowling ball experiences a net force of 15N. What will be its acceleration.
a) 35 m/s²
b) 7 m/s²
c) 5 m/s²
d) 35 m/s²

Section (B): Structured Questions

CRQs:

1. State Newton's second law of motion.
2. How does mass affect an object's acceleration?
3. What are the different types of forces that can act on an object?
4. How do you calculate net force?
5. State the law of conservation of momentum.
6. What is the difference between elastic and inelastic collisions?
7. How does impulse relate to force and time?
8. How does friction influence the motion of an object?

ERQs:

1. Explain Newton's Second Law of Motion and how it relates force, mass, and acceleration. Provide an example to illustrate the concept.
2. How does the conservation of momentum apply in each type of collision? Give real-life examples of both types of collisions.
3. Explain how the concept of impulse is related to the change in momentum of an object. Provide an example of an everyday life where impulse plays a significant role.
4. State the law of conservation of momentum. Provide an example from everyday life that demonstrates the principle of momentum conservation.

Numericals:

1. A car weighing 9800 N is moving with a speed of 40 Km/h. On the Application of breaks it comes to rest after traveling a distance of 50 meters. Calculate the average retarding force?
(Ans: 1234. 57 N)
2. A helicopter weighs 3920 N. Calculate the force on it if it is ascending up at the rate of 2m/s^2 . What will be the force on helicopter if it is moving up with a constant speed of 4 m/s?
(Ans: 4720 N, 3920 N)
3. A 100 grams bullet s fired from a 10 kg gun with a speed of 1000m/s. What is the speed of recoil of the gun?
(Ans: 10 m/s)
4. A machine gun fires 10 bullets per second into a target. Each bullet weighs 20 gram and had a speed of 1500 m/s. Find the necessary force to hold the gun in position?
(Ans: 300 N)
5. A 50 grams bullet is fired into a 10 kg block that is suspended by a long cord so that it can swing as a pendulum. If the block is displaced so that its center of gravity rises by 10cm, what was the speed of bullet?
(Ans: 281.4 m/s)
6. A 70-gram ball collides with another ball of mass 140 gram. The initial velocity of the first ball is 9m/s to right while the second ball is at rest. If the collision were perfectly elastic, what would be the velocity of two balls after the collision?
(Ans: - 3m/s, 6 m/s)
7. A truck weighing 2500 kg and moving with a velocity of 21m/s collides with a stationary car weighing 1000 kg. The truck and car move together after the impact. Calculate their common velocity?
(Ans: 15 m/s)



Amusement Park, Hill park, Karachi

In this unit student should be able to:

- Define angular displacement, Angular Velocity and Angular acceleration and express angular displacement in radians.
- Solve problems by using $S = r\theta$ and $v = r\omega$
- Describe the qualitatively motion in curved path due to perpendicular Force
- Derive and use centripetal acceleration $a = r\omega^2, a = v^2/r$.
- Solve problems using centripetal Force $F = mr\omega^2, F = mv^2/r$
- Describe situations in which the centripetal acceleration is caused by tension force, a Frictional force, a gravitational force, or a Normal Force.
- Explain when a vehicle travels round a banked curved at specified speed for the banking angle, the horizontal component of the normal force on vehicle causes the centripetal acceleration.
- Describe the equation $\tan\theta = v^2/rg$, relating banking angle θ to the speed V of vehicle and the radius curvature r .
- Define the term orbital velocity and derive relationship between orbital velocity, gravitational constant, mass and radius of orbit.
- Define the moment of inertia.
- Use the formula of moment of inertia of various bodies for solving problems.
- Define the angular momentum
- Explain the law of conservation of momentum.
- Define the Torque as the cross product of force and moment arm.
- Derive a relation between torque, moment of inertia and angular acceleration.

4.1 Kinematics of Angular Motion

The *kinematics* of rotational motion describes the relationships among rotation angle, angular velocity, angular acceleration, and time. Relationship between angle of rotation, angular velocity, and angular acceleration to their equivalents in linear *kinematics*.

We derive all kinematic equations for rotational motion under constant acceleration:

4.1.1 Rotational Quantities

Rotational motion happens when the body itself is spinning. Examples the earth spinning on its axis and the turning shaft of an electric motor. We see a turning wheel motion, but we need a different system of measurement.

There are three basic systems of defining angle measurement.

The revolution is one complete rotation of a body. This unit of measurement of rotational motion is the number of rotations. its unit is the revolution (rev).

Angular Displacement

It is defined as the angle with its vertex at the center of a circle whose sides cut off an arc on the circle equal to its radius figure 4.1. where $s = r$ and $\theta = 1$ rad, then

$$\theta = \frac{s}{r} \dots\dots\dots (4.1)$$

Where

θ = angle determined by s and r i.e. angular displacement

s = length of arc of the circle

r = radius of the circle

Angle θ is measured in radians is defined as **the ratio of two lengths: the length of the arc and the radius of a circle**. Since the length units in the ratio cancel, the radian is a dimensionless unit. A useful relationship is 2π rad equals one revolution. Therefore, $1 \text{ rev} = 360^\circ = 2\pi \text{ rad}$

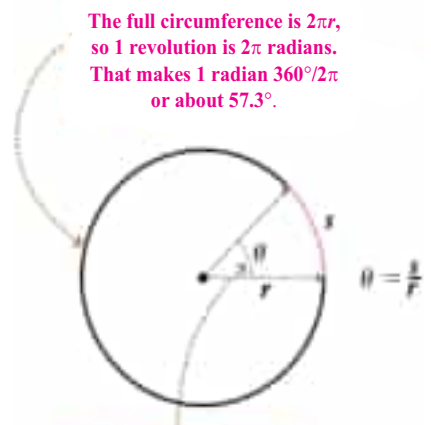

The full circumference is $2\pi r$, so 1 revolution is 2π radians. That makes 1 radian $360^\circ/2\pi$ or about 57.3° .

Angle in radians is the ratio of arcs s to radius r . $\theta = s/r$. Here θ is a little less than 1 radian.

Fig: 4.1

A second system of angular measurement divides the circle of rotation into 360 degrees ($360^\circ = 1 \text{ rev}$). One degree is $1/360^\circ$ of a complete revolution.

The radian (rad), which is approximately 57.3° or exactly $(360 / 2\pi)$, is a third angular unit of measurement.

$$1^\circ = 2\pi / 360^\circ = 0.0175 \text{ rad}$$

Angular Velocity

Any object which is rotating about an axis, every point on the object has the same angular velocity. The tangential velocity of any point is proportional to its distance from the axis of rotation.

Unit 4: Rotational and Circular Motion

Angular velocity is the rate of change of angular displacement and denoted by

$$\omega_{average} = \frac{\Delta\theta}{\Delta t} \dots\dots\dots (4.2)$$

ω = Angular Velocity

θ = Angular Displacement

t = time

This angular velocity is generally measured in **radians per second**, but angles are actually dimensionless. The SI unit for angular velocity is s^{-1} but it usually writes as $rad\ s^{-1}$.

Angular velocity is considered to be a vector quantity, with direction along the axis of rotation in the right – hand rule
The instantaneous angular velocity, which is defined as the instantaneous rate of change of the angular displacement with respect to time, can then be written as

$$\omega_{inst} = \lim_{t \rightarrow 0} \frac{\Delta\theta}{\Delta t} \dots\dots\dots (4.3)$$

The angular velocity is also referred as angular frequency.

$$\omega = \frac{2\pi}{t} = 2\pi f \dots\dots\dots (4.4)$$

Another practical unit of angular velocity is revolution per minute (rpm) , usually used in industrial rotatory machines and odometer of vehicles.

$$1 \text{ rpm} = \left(\frac{2\pi}{60}\right) \text{ rad/s}$$

Right -hand rule for angular quantities

Lets consider a circular disk rotating counter clockwise as shown in figure 4.3a, in result the direction of angular velocity vector will be outward direction. In similar way when disk start to rotate clockwise then the direction of angular velocity vector will be inward as represented in figure 4.3b.

Angular Acceleration

In rotational motion, changing the rate of rotation involves a change in angular velocity and results in an angular acceleration. For uniformly accelerated rotational motion, angular acceleration is defined as the rate of change of angular velocity. That is

$$\alpha = \frac{\Delta\omega}{t} \dots\dots\dots (4.5)$$

α = Angular acceleration

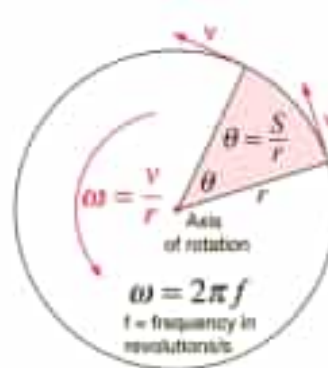

Fig: 4.2

As $f = 1/t$

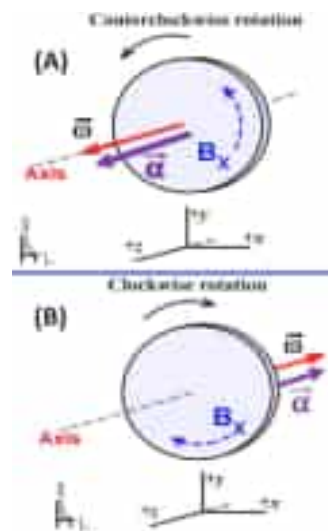

Fig: 4.3

$\Delta\omega$ = Change in angular velocity

t = time

It's unit is rad/s^2 .

The instantaneous angular acceleration, which is defined as the **instantaneous rate of change of the angular velocity with respect to time**.

$$\alpha_{inst} = \lim_{t \rightarrow 0} \frac{\Delta\omega}{t} \dots\dots\dots (4.6)$$

4.1.2 Relationship between Linear and Angular quantities

Consider an object revolving in circle, which involve angular as well as linear motions i.e. stadium race ground, moving in circular laps but counted in linear terms. The equations of both motions as under:

$$\theta = s/r \text{----- (i)}$$

$$v = s/t \text{----- (ii)}$$

$$\omega = \theta / t \text{----- (iii)}$$

Therefore, combining and substituting s / r for θ in eq (iii), we obtain

$$\omega = \frac{s}{rt}$$

$$\omega (r) = \left(\frac{s}{t}\right) (r) \quad \text{Multiply both sides by r}$$

$$\omega r = \frac{s}{t} \quad \text{whereas } s/t = v$$

$$V = r \omega \quad \dots\dots\dots (iv)$$

V = linear velocity of point on circle also known as tangential velocity

r = radius

ω = angular speed.

Similarly

If $V = r \omega$ is divide both sides by t then

$$\frac{v}{t} = r \frac{\omega}{t}$$

$$a = r \alpha \quad \dots\dots\dots (v)$$

a = Linear or tangential acceleration

α = angular acceleration

r = radius

Self-Assessment Questions:

1. How does angular velocity differ from linear velocity? How are their units related?
2. Describe the difference between clockwise and counterclockwise rotations in terms of angular displacement and angular velocity.
3. Can angular acceleration be negative? If so, what does a negative angular acceleration indicate about the object's motion?

Worked Example 4.1

The platter of the hard drive of a computer rotates at 7300 rpm (a) What is the angular velocity of the platter? (b) if the reading head of the drive is located 3.1 cm from the rotation axis, what is the linear speed of the point on the platter just below it? (c) If a single bit requires 0.55 μm of length along the direction of motion, how many bits per second can the writing head write when it is 3.1 cm from the axis?

Data:

- rev = f = 7300 rpm
- $\omega = ?$
- r = 3.1 cm
- v = ?
- size of bit = 0.55 μm
- Size of bits / time = ?

Solution:

Step 1: (a)

$$f = \frac{7300 \text{ rev/min}}{60 \text{ s/min}} = 121.7 \frac{\text{rev}}{\text{s}} = 121.7 \text{ Hz}$$

The angular velocity is

$$\omega = 2\pi f = 2\pi \times 121.7 = 764.5 \frac{\text{rad}}{\text{s}}$$

Step 2: (b) The linear speed of point 3.1 cm out from the axis is given by

$$v = r\omega$$

$$v = 0.031 \times 764.5 = 23.7 \frac{\text{m}}{\text{s}}$$

Step 3: (c) Each bit requires 0.55×10^{-6} m, so at a speed 23.7 m/s, the number of bits passing the head per second is

$$= \frac{23.7 \frac{\text{m}}{\text{s}}}{0.55 \times 10^{-6} \frac{\text{m}}{\text{bit}}} = 43 \times 10^6 \text{ bits per second}$$

or 43 megabits /s

Linear and Rotational Equations of motion

The angular equations for constant angular acceleration are analogous to kinematic equations, their comparison is given as under:

Table: 4.1(Put this table in Do You Know)

Linear Motion	Rotational Motion	
$S = vt$	$\theta = \frac{s}{r}$ or $\theta = \omega t$	
$S = V_i t + \frac{1}{2} at^2$	$\theta = \omega_i t + \frac{1}{2} \alpha t^2$	a constant α constant

$V_{avg} = \frac{V_f + V_i}{2}$	$\omega_{avg} = \frac{\omega_f + \omega_i}{2}$	
$V_f = V_i + at$	$\omega_f = \omega_i + \alpha t$	a constant α constant
$2 a s = V_f^2 - V_i^2$	$2\alpha\theta = \omega_f^2 - \omega_i^2$	a constant α constant

Worked Example 4.2

A motor cycle wheel turns 3620 times while being ridden for 6.50 minutes. What is the angular speed in rev/min (rpm)?

Data:

$t = 6.50$ min

no of revolutions = 3620 rev

$\omega = ?$

Solution:

Step 1: formula

$$\begin{aligned} \omega &= \frac{\theta}{t} \\ &= \frac{3620 \text{ rev}}{6.5 \text{ min}} = 557 \text{ revolutions per minutes} \end{aligned}$$

$$\omega = 557 \text{ rpm}$$

4.2.1 Centripetal Force

An object moving in a circle is experiencing an acceleration, though it's moving along perimeter of circle, its velocity is changing subsequently an acceleration. According to Newton's second law of motion, an object experiences an acceleration must have force behind it.

The direction of the net force is in the same direction of acceleration, which is directed to support i.e. center or inward acceleration. The centripetal means center seeking.

The force which causes the acceleration is directed towards the center of the circle and is called a centripetal force.

Centripetal force is exerted towards center of the circle. if the string break, however, there would no longer be a centripetal force acting on stone, which would fly off tangent to the circle.

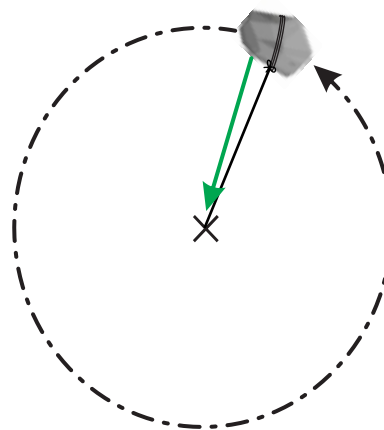

Fig: 4.4

Unit 4: Rotational and Circular Motion

The Centripetal Force Formula is given as the product of mass and tangential velocity squared, divided by the radius that implies that on doubling the tangential velocity, the centripetal force will be quadrupled. Mathematically it is written as:

$$F_c = \frac{mv^2}{r} \dots\dots\dots(4.7)$$

Some Examples:

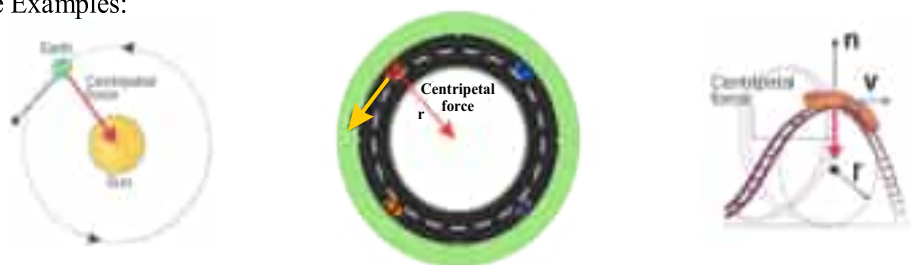

(a) Planets orbiting Sun (b) Turning car at roundabout (c) Roller coaster over loop

Fig: 4.5

4.2.2 Centripetal Acceleration.

Figure 4.6 shows an object moving in a circular path at constant speed. The direction of the instantaneous velocity is shown at two points along the path. Acceleration is in the direction of the change in velocity, which points directly toward the center of rotation i.e. the center of the circular path. This is labeled with the vector diagram in the figure. We call the acceleration of an object moving in uniform circular motion (resulting from a net external force) the **centripetal acceleration**; centripetal means “toward the center” or “center seeking.”

Centripetal acceleration, the acceleration of an object moving in a circle, directed towards the center.

Derivation for centripetal acceleration

Following the figure 4.6, observe that the triangle formed by the velocity vectors and the one formed by the radii r and ΔS are similar. Both the triangles ABC and PQR are isosceles triangle i.e. triangles having two sides identical. The two equal sides of the velocity vector triangles are the speeds $v_1 = v_2 = v$. Using the properties of two identical triangles we get

$$\frac{\Delta v}{v} = \frac{\Delta S}{r}$$

rearranging for Δv , we get

$$\Delta v = \frac{v}{r} \Delta S \quad \text{Dividing both sides,}$$

$$\frac{\Delta v}{\Delta t} = \frac{v}{r} \frac{\Delta S}{\Delta t}$$

$\frac{\Delta v}{\Delta t} = a_c$ and $\frac{\Delta S}{\Delta t} = v$ then, the magnitude of centripetal acceleration is

$$a_c = \frac{v^2}{r} \dots\dots\dots (4.8)$$

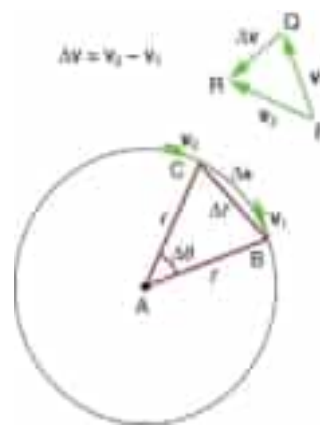

Fig: 4.6

It is useful to show centripetal acceleration in terms of angular velocity. Substituting $V = r \omega$ into centripetal acceleration formula, we get

$$a_c = \frac{(r\omega)^2}{r} = r\omega^2$$

$$a_c = r\omega^2 \dots\dots\dots (4.9)$$

We can express the magnitude of centripetal acceleration using either of two equations.

Self-Assessment Questions:

1. In what direction does centripetal acceleration point for an object moving in a circular path?
2. Is centripetal force a conservative force? Why or why not?

Worked Example 4.3

What is the magnitude of force and the centripetal acceleration of a car having mass of 300 kg following a curve of radius 500 m at a speed of 100 km/h? also compare the acceleration with that due to gravity for this fairly gentle curve taken at highway speed.

Data:

- $m=300\text{kg}$
- $r = 500 \text{ m}$
- $V = 100 \text{ km/h} = 27.8 \text{ m/s}$
- $a_c = ?$

Solution: Step 1: formula

$$a_c = \frac{v^2}{r}$$

$$a_c = \frac{(27.8)^2}{500}$$

$$a_c = 1.54 \text{ m/s}^2$$

Step 2: To calculate the magnitude of force

$$F = ma_c = mv^2/r$$

$$F = ma_c = (300)(27.8)^2/500$$

$$F = 462\text{N}$$

To compare this centripetal acceleration with acceleration due to gravity by taking ratio, we get

$$\frac{a_c}{g} = \frac{1.54}{9.8} g = 0.157 g$$

0.157 g is noticeable gravity impact especially if you don't wear seat belt.

4.2.4 Centripetal acceleration caused by Tension force.

An acceleration must be produced by a force. Any force or combination of forces can cause a centripetal or radial acceleration. For examples are the tension in the rope constraint the motion of the ball, the force of Earth's gravity on the Moon to keep them in orbit, friction between roller skates, a rink floor, and a banked roadway's force on a car. Any net force causing uniform circular motion is called a centripetal force. The direction of a centripetal force is toward the center of curvature, the same as the direction of centripetal acceleration.

If a ball is tied to the end of a string and whirling in a circle, the ball accelerates towards the center of the circle as shown in figure 4.7. The centripetal force which causes the inward acceleration is from the tension in the string caused by the person's hand pulling the string plus the weight of the ball also having its implications. The centripetal force on the object equals the tension of the string plus the weight of the ball, both acting toward the center of the vertical circle. Mathematically:

$$F_c = F_t + F_w$$

$$F_t = \frac{mv^2}{r} - mg$$

The centripetal force on the object is equal to the difference between the tension of the string and the weight of the object. The tension is exerted inward toward the center of the vertical circle, while the weight is directed away from the center of the vertical circle. Mathematically:

$$F_c = F_t - F_w$$

$$F_t = \frac{mv^2}{r} + mg \dots\dots\dots (4.10)$$

If the string breaks there is no longer a resultant force acting on the ball, so it will continue its motion in a straight line at constant speed.

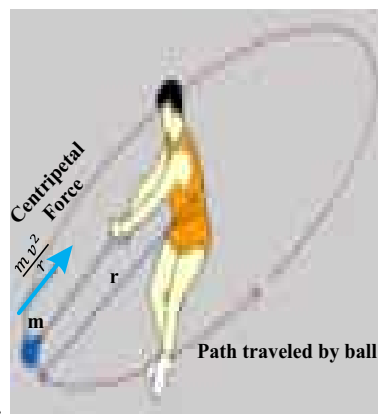

Fig: 4.8

4.2.5 Forces acting on Banked Curve

A banked curve is a curve that has its surface at angle with respect to the ground on which the curve is positioned as shown in figure 4.8. The reason for **banking curves is to decrease the moving object depends on the force of friction.** On a curve that is not banked, a car traveling along that curve will experience a force of static friction that will point towards the center of the circular pathway restricted by the moving car. This frictional force will be responsible for creating centripetal acceleration, which in turn will allow the car to move along the curve. On a banked curve however, the normal force acting on the object such as a car; will act at an angle with the horizontal, and that will create a component normal force that acts along the x axis. This component normal force will now be responsible for creating the centripetal acceleration required to move the car along the curve. Therefore, for every single angle, there exists a velocity for which no friction is required at all to move the object along the curve. This means that the car will be able to turn even under the most slippery conditions (ice or water).

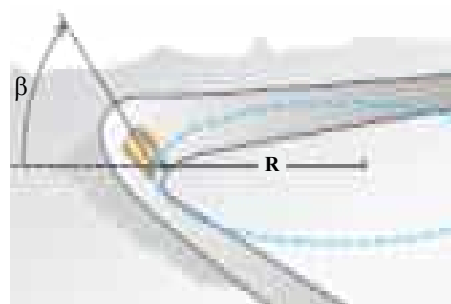

Fig: 4.8

4.2.6 Banking dependence on angle and speed of vehicle.

Banked Curves

Let us suppose banked curves, where the slope of the road helps you assign the curve figure 4.10. The greater the angle θ , the faster and easily you can take the curve. Race tracks for bikes as well as cars, for example, often have steeply banked curves. In an “ideally banked curve,” the angle θ is such that you can assign the curve at a certain speed without the support of friction between the tires and the road. We will derive an expression for θ for an ideally banked curve. For ideal banking, the net external force equals the horizontal centripetal force in the absence of friction. The components of the normal force N in the horizontal and vertical directions must equal the centripetal force and the weight of the car,

A free-body diagram is shown in figure 4.9 for a car on a frictionless banked curve. If the angle θ is ideal for the speed and radius r , then the net external force equals the necessary centripetal force. The only two external forces acting on the car are its weight and the normal force of the road N . (A frictionless surface can only exert a force perpendicular to the surface—that is, a normal force.) These two forces must add to give a net external force that is horizontal toward the center of curvature and has magnitude mv^2/r . As it is a crucial force and is horizontal, we use a coordinate system with vertical and horizontal axes. Only the normal force has a horizontal component, so this must equal the centripetal force, that is,

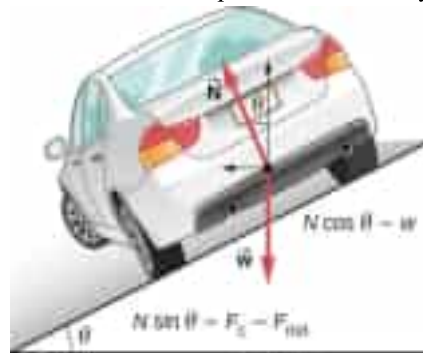

Fig: 4.9

$$N \sin \theta = \frac{mv^2}{r}$$

Because the car does not leave the surface of the road, the net vertical force must be zero, meaning that the vertical components of the two external forces must be equal in magnitude and opposite in direction. From figure 4.10, we note that the vertical component of the normal force is $N \cos \theta$, and the only other vertical force is the car’s weight. These must be equal in magnitude; thus,

$$N \cos \theta = mg$$

Now we can combine these two equations to eliminate N and get an expression for θ , as desired. Solving the second equation for $N=mg/(\cos \theta)$ and substituting this into the first yields

$$mg \frac{\sin \theta}{\cos \theta} = \frac{mv^2}{r}$$

$$mg \tan \theta = \frac{mv^2}{r}$$

$$\tan \theta = \frac{v^2}{rg}$$

$$\theta = \tan^{-1} \left(\frac{v^2}{rg} \right) \dots\dots\dots (4.11)$$

This expression can be understood by considering how θ depends on v and r . A large θ is obtained for a large v and a small r . That is, roads must be steeply banked for high speeds and

sharp curves. Friction helps, because it allows you to take the curve at greater or lower speed than if the curve were frictionless. Note that θ does not depend on the mass of the vehicle.

Worked Example 4.4

Curves on some test tracks and race courses, such as M-1 Islamabad – Lahore Motorway, are very steeply banked. This banking, with the support of tire friction and very stable car configurations, allows the curves to be taken at very high speed. To illustrate, calculate the speed at which a 100 m radius curve banked at 30° should be driven if the road were frictionless.

Approach

We first note that all terms in the expression for the ideal angle of a banked curve except for speed are known; thus, we need only rearrange it so that speed appears on the left-hand side and then substitute known quantities.

Solution:

Step 1:

Data:

$$r = 100 \text{ m}$$

$$\theta = 30^\circ$$

$$v = ?$$

Step 2:

$$\tan \theta = \frac{v^2}{rg}$$

$$v = \sqrt{r g \tan \theta}$$

Step 3:

$$v = \sqrt{100 \times 9.8 \times \tan 30^\circ}$$

$$v = 23.8 \text{ m/s}$$

4.3 Orbital Velocity

Orbital velocity is the speed required to achieve orbit around a heavenly body, such as a planet or a star. This requires traveling at a sustained speed that:

- Aligns with the heavenly body's rotational velocity
- Is fast enough to counteract the force of gravity pulling the orbiting object toward the body's surface
- An airplane can travel in the sky but it does not travel at a velocity fast enough to sustain orbit around the earth. This means that once the airplane's engines are turned off, the plane will slow down and be pulled back down to earth, via the force of gravity. By contrast, a satellite (such as the one that powers your phone's GPS or the one that transmits a Direct TV signal) does not need to expend fuel to maintain its orbit around the earth. This is because such satellites travel at a velocity that overrides the force of gravity.

4.3.1 Velocity, Radius

Newton's laws of motion are governing motion of all objects. The same laws which govern the motion of objects on earth also extended to the heavenly bodies to govern the motion of planets, moons, and other satellites. Already we had discussed the bodies in circular motion.

Orbital Speed

Suppose a satellite with mass $M_{\text{satellite}}$ orbiting a central body with mass M_{Central} . The central body could be a planet, the moon, the sun or any other heavenly body which may be capable of causing reasonable acceleration over a less massive body nearby. When the satellite is moving in a circular motion, then the net centripetal force acting upon this orbiting satellite is

$$F_c = \frac{M_{\text{satellite}} V^2}{R}$$

This net centripetal force is the resultant of the gravitational force which attracts the satellite towards the central body

$$F_G = \frac{G M_{\text{satellite}} M_{\text{central}}}{R^2}$$

Since $F_c = F_G$, then

$$\frac{M_{\text{satellite}} V^2}{R} = \frac{G M_{\text{satellite}} M_{\text{central}}}{R^2}$$

$$V^2 = \frac{G M_{\text{central}}}{R}$$

$$V = \sqrt{\frac{G M_{\text{central}}}{R}} \dots\dots\dots (4.12)$$

G = Gravitational Constant = $6.67 \times 10^{-11} \text{ Nm}^2 / \text{kg}^2$

M_{central} = Mass of earth = $5.98 \times 10^{24} \text{ kg}$

R = distance from the center of object to the center of earth

- This means that all satellites, whatever their mass, will travel at the same speed v in a particular orbit radius r
- Recall that since the direction of a planet orbiting in circular motion is constantly changing, it has centripetal acceleration

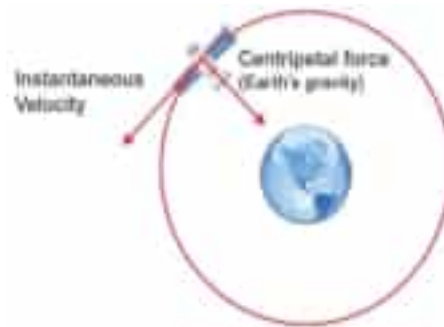

Fig: 4.10
Orbital velocity of satellite

Time Period and Orbital Radius

Since a planet or a satellite is traveling in circular motion when in orbit, its orbital time periods T to travel the circumference of the orbit $2\pi r$, the linear speed is

$$V = \frac{2\pi R}{T}$$

Substituting V

$$V^2 = \left(\frac{2\pi R}{T}\right)^2 = \frac{G M_{\text{central}}}{R} \quad \text{Squaring both sides}$$

$$T^2 = \frac{4\pi^2 R^3}{G M_{\text{central}}} \dots\dots\dots (4.13)$$

Where:

- T = Time period of the orbit (s)
- R = orbital radius (m)
- G = Newton's Gravitational Constant
- M = mass of the object being orbited (kg)

The equation shows that the orbital period T is related to the radius r of the orbit. This is also known as Kepler's third law

Self-Assessment Questions:

1. What factors influence the orbital velocity of an object around a celestial body, such as a planet or a star?
2. Compare the orbital velocity of a satellite around earth and moon. How do their orbital velocities differ?

Worked Example 4.5

The International Space Station orbits at an altitude of 400 km above the surface of the Earth. What is the space station's orbital velocity?

Solution:

Step 1:

The orbital velocity depends on the distance from the center of mass of the Earth to the space station. This distance is the sum of the radius of the Earth and the distance from the space station to the surface:

$$r = (6.38 \times 10^6 \text{ m}) + (400 \text{ km})$$

$$r = 6380000 + 400000 \text{ m}$$

$$r = 6780000 \text{ m}$$

Step 2:

The orbital velocity can be found using the formula:

$$V = \sqrt{\frac{G M_{\text{central}}}{R}}$$

Step 3:

$$V = \sqrt{\frac{6.673 \times 10^{-11} \times 5.98 \times 10^{24}}{6780000}}$$

$$V = 7672 \text{ m/s}$$

The orbital velocity of the International Space Station is **7672 m/s**.

4.4 Moment of Inertia

Moment of inertia is the property of the body by virtue of it resists angular acceleration, which is the sum of the products of the mass of each particle in the body with the square of its distance from the axis of rotation.

Or

simply it can be described as a quantity that adopts the amount of torque necessary for a specific angular acceleration in a rotational axis. Moment of Inertia is also known as the rotational inertia or angular mass. The higher the moment of inertia, the more resistant a body is to angular rotation.

A body is usually made from several small particles forming the entire mass. The mass moment of inertia depends on the distribution of each individual mass concerning the perpendicular distance to the axis of rotation.

DO YOU KNOW?



A large - diameter cylinder has a greater rotational inertia than one of smaller diameter but has equal mass.

Mathematically, the moment of inertia can be expressed in terms of its individual masses as the sum of the product of each individual mass and the squared perpendicular distance to the axis of rotation.

$$I = \Sigma m r^2 \dots\dots\dots (4.14)$$

I = Moment of Inertia

m = Mass

r = distance to axis of rotation

The moment of inertia is measured in kilogram square meters ($\text{kg}\cdot\text{m}^2$), its dimensional formula is $[M^1L^2T^0]$.

The moment of inertia depends upon the following factors:

- Shape and size of the body
- The density of body
- Axis of rotation (distribution of mass relative to the axis)

4.4.2 Rotational Inertia of a two particle system

Consider a rigid body containing of two particles of mass m connected by a rod of length L with negligible mass.

(a) Two particles each at perpendicular distance $\frac{1}{2} L$ from the axis of rotation.

For two particles each at perpendicular distance $\frac{1}{2} L$ from the axis of rotation, we have:

$$I = \Sigma m r^2 = (m) \left(\frac{1}{2}L\right)^2 + (m) \left(\frac{1}{2}L\right)^2$$

$$I = \frac{1}{2} mL^2 \dots\dots\dots (4.15)$$

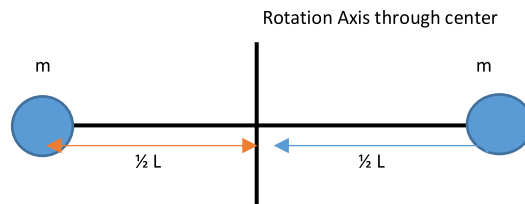

Fig: 4.11

(b) Rotational inertia I of the body about an axis through left end of rod and parallel to the first axis.

Here it is simple to find I using either method. The first is as in part (a) we have done. The perpendicular distance r is zero for the particle on left and L for the particle on the right. We have:

$$I = m (0)^2 + mL^2$$

$$I = mL^2 \dots\dots\dots (4.16)$$

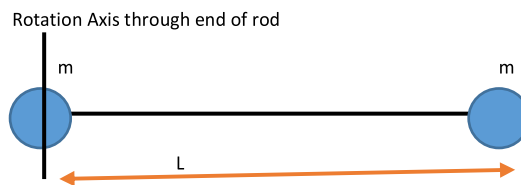

Fig: 4.12

Second Method:

As I_c about an axis through the center of mass and because the axis here is parallel to that center of axis, we can apply the parallel-axis theorem.

$$I = I_c + Mh^2$$

$$I = \frac{1}{2}mL^2 + (2m)\left(\frac{1}{2}L\right)^2$$

$$I = mL^2$$

Moment of Inertia of Various bodies:

Consider a solid cylinder with mass **M**, and radius **R**. The moment of inertia of a solid cylinder rotating about its central axis is given by the formula:

$$I = \frac{1}{2} M R^2 \dots\dots\dots (4.17)$$

Let's assume we have a solid cylinder with a mass of 2 kg and a radius of 0.5 meters. The moment of inertia would be:

$$I = \frac{1}{2} (2\text{kg}) (0.5\text{m})^2$$

$$I = 0.5 \text{ kg} \cdot \text{m}^2$$

the moment of inertia of the solid cylinder is **0.5 kg · m²**

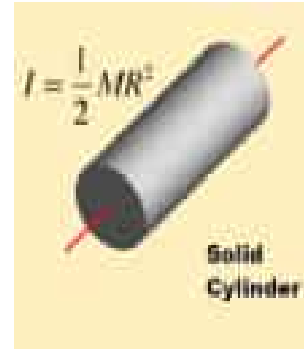

Fig: 4.13

Moment of Inertia of a Hollow Cylinder:

Consider a hollow cylinder with mass **M**, inner radius **a**, and outer radius **b**. The moment of inertia of a hollow cylinder rotating about its central axis is given by the formula:

$$I = \frac{1}{2} m (a^2 + b^2) \dots\dots\dots (4.18)$$

Let's consider we have a hollow cylinder with a mass of 3 kg, an inner radius of 0.4 meters, and an outer radius of 0.6 meters. The moment of inertia would be:

$$I = \frac{1}{2} (3\text{kg})[(0.4)^2 + (0.6)^2]$$

$$I = 1.2 \text{ kg} \cdot \text{m}^2$$

The moment of inertia of the hollow cylinder is **1.2 kg · m²**

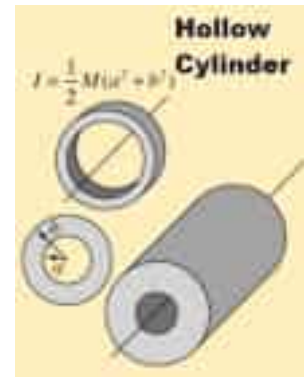

Fig: 4.14

Moment of Inertia of a Sphere:

Consider a solid sphere with mass **M** and radius **R**. The moment of inertia of a solid sphere rotating about its center is given by the formula:

$$I = \frac{2}{5} M R^2 \dots\dots\dots (4.19)$$

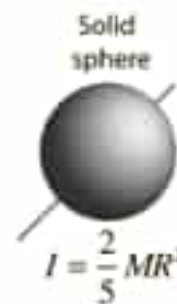

Fig: 4.15

Let's assume we have a solid sphere with a mass of 1 kg and a radius of 0.3 meters. The moment of inertia would be:

$$I = \frac{2}{5} (1\text{kg}) (0.3\text{m})^2$$

$$I = 0.036 \text{ kg} \cdot \text{m}^2$$

The moment of inertia of the solid sphere is **0.036 kg·m²**

These examples demonstrate how to calculate the moment of inertia for different bodies. However, it's important to note that the moment of inertia can vary depending on the axis of rotation and the specific mass distribution within the object.

Self-Assessment Questions:

1. How does moment of inertia differ from mass? What role does mass play in moment of inertia?
2. How does the moment of inertia of an object change when its axis of rotation is shifted closer to or farther from its center of mass?

DO YOU KNOW?



Even though the two cylinders are of equal mass, the hollow cylinder has more rotational inertia because its mass is concentrated farther from its axis of rotation.

4.5 Angular Momentum

Rotating bodies show the same reluctance i.e. inertia to a change in their angular velocity as compared to bodies moving in a straight line do to a change in their linear velocity. This is due to the angular momentum of the object. If you try to get on a bicycle and try to balance without a kickstand you are probably going to fall off. But once you start pedaling, these wheels pick up angular momentum. They are going to resist change, thereby balancing gets easier.

4.5.1 Angular Momentum of a point particle.

Suppose a point particle of mass *m* in Cartesian coordinates at position *r* with respect to origin *O*, is having momentum *p* as shown in figure 4.16. The point particle is accelerating around a fixed point e.g. Earth revolving around the Sun.

The angular momentum \vec{L} , of a point particle is the vector product of its position / moment arm and linear momentum.

$$\vec{L} = \vec{r} \times \vec{p} \dots\dots\dots (4.20)$$

The magnitude of angular momentum is

$$\vec{L} = rp \sin\theta \quad \text{as } p = mv$$

Where θ is angle between position and momentum vectors.

Its direction is perpendicular to both position and linear momentum and determined by right-hand rule.

$$\vec{L} = mvr \sin \theta$$

For $\theta = 90^\circ$

$$\vec{L} = mvr$$

The maximum magnitude of angular momentum.

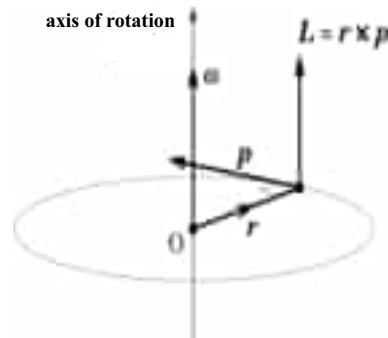

Fig: 4.16

4.5.2 Law of conservation of angular momentum

The law of conservation of angular momentum states that when no resultant external torque acts on a body, its angular momentum remains constant.

In figure 4.17, consider a particle in uniform circular motion due to a force acting on the particle that is centripetal force required to deflect the particle to keep it in circular path.

(The central force is a force whose line of action passes through a fixed point.) The centripetal force always points towards the center of the circle so it produces no torque about an origin at the center of the circle.

The law of conservation of angular momentum then ensures that the angular momentum of the particle is constant. The angular momentum is constant in magnitude (mrv remains fixed) and constant in direction (the motion is confined to the plane of rotation).

It is worth emphasizing that the above discussion relies on the origin being at the center of the circle. In Figure 4.16 a different origin O has been chosen, on the axis of rotation but out of the plane of rotation. In this case angular momentum is

$$\vec{L} = r \times p$$

$$\vec{L} = (r_{\parallel} + r_{\perp}) \times p$$

$$\vec{L} = (r_{\parallel} \times p) + (r_{\perp} \times p)$$

that the angular momentum has a component $L_{\perp} = r_{\perp} \times p$ which is perpendicular to the axis of rotation and is not conserved. This is not a problem because, *relative to the origin of Figure 6*, the particle experiences a torque $\tau_{\perp} = r_{\perp} \times F$ where F is the centripetal force acting along $-r_{\perp}$.

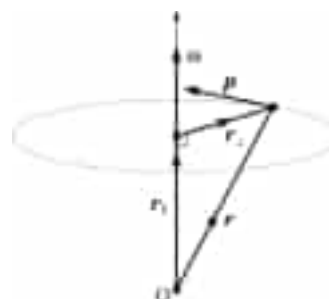

Fig: 4.17

Moreover, because r_{\parallel} is constant we have

$$\frac{dL_{\perp}}{dt} = r_{\parallel} \times \frac{dp}{dt} = r_{\parallel} \times F = \tau_{\perp}$$

so the rate of change of L_{\perp} is supported by the existence of τ_{\perp} . At the same time, the component of angular momentum parallel to the axis of rotation remains constant because there is no torque in that direction.

$$\frac{dL_{\parallel}}{dt} = \tau_{\parallel}$$

$$\frac{dL_{\parallel}}{dt} = 0$$

where $\tau = 0$ (integrating both sides)

$L = \text{constant}$

Hence, the angular momentum of the particle is conserved if the net torque acting on it is zero.

Self-Assessment Questions:

1. How is angular momentum different from linear momentum? Explain the key differences between the two.
2. How does angular momentum change when an object's moment of inertia is altered, but its angular velocity remains constant? Provide an example to illustrate this concept.

Worked Example 4.6

A basketball spinning on the finger of an athlete has angular velocity $\omega = 120.0$ rad/s. The moment of inertia of a sphere that is hollow, where M is the mass and R is the radius. If the basketball has a weight of 0.6000 kg and has a radius of 0.1200 m, what is the angular momentum of this basketball?

Solution:

Data:

$$\omega = 120 \text{ rad/s}$$

$$m = 0.60 \text{ kg}$$

$$r = 0.120 \text{ m}$$

$$L = ?$$

We can find the angular momentum of the basketball by using the moment of inertia of a sphere that is hollow, and the formula. The angular momentum will be:

$$L = I\omega$$

$$I = \frac{2}{3} MR^2$$

$$I = 0.66 \times 0.60 \times (0.12)^2$$

$$I = 5.76 \times 10^{-3}$$

$$L = 5.76 \times 10^{-3} \times 120$$

$$L = 0.6912 \text{ kg}\cdot\text{m}^2/\text{s}$$

The angular momentum of the basketball that is spinning will be $0.6912 \text{ kg}\cdot\text{m}^2/\text{s}$.

4.6 Torque

Torque is an important quantity for describing the dynamics of a rotating rigid body. There are many applications of torque in our world. We all have an intuition about torque, as when we use a large wrench to unscrew a stubborn bolt. Torque is at work in unseen ways, as when we press on the accelerator in a car, causing the engine to put additional torque on the engine. Or every time we move our bodies from a standing position, we apply a torque to our limbs. In physics, torque is simply the tendency of a force to turn or twist. Example of torque.

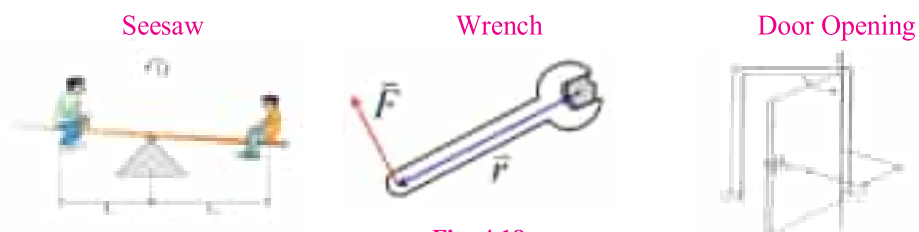

Fig: 4.18

4.6.1 Torque or Moment of Force

Torque is produced when a force is applied to an object produce a rotation. **This turning effect of the force about the axis of rotation is called torque.** torque is also known as moment of force.

Unit 4: Rotational and Circular Motion

Consider a body which can rotate about O (axis of rotation). A force F acts on other end whose position vector with respect to O is r as shown in figure 4.19. The distance from the pivot point to the point where the force acts is called the moment arm. The force is in x-y plane, so resolved to act accordingly. Torque is defined as **the cross product of moment arm and force**.

$$\vec{\tau} = \vec{r} \times \vec{F} \dots \dots \dots (4.21)$$

$$|\tau| = r \cdot F \sin \theta$$

$$|\tau| = r (F \sin \theta)$$

$$|\tau| = F (r \sin \theta)$$

Torque is positive if directed outward from paper and negative inward to paper.

Torque is always perpendicular to the plane r and F . Thus clockwise torque is negative and counter-clockwise is positive. The SI unit of torque is kgm^2/s^2 and dimensionally it can be written as $[\text{ML}^2\text{T}^{-2}]$.

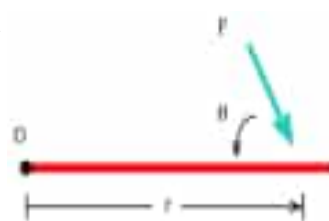

Fig: 4.19

DO YOU KNOW?

You imagine pushing a door to open it. Your push causes the door to rotate about its hinges. How hard you need to push depends on the distance you are from the hinges. The closer you are to the hinges, the harder it is to push. This is what happens when you try to push open a door on the wrong side. The torque you created on the door is smaller than it would have been had you pushed the correct side.

Self-Assessment Questions:

1. What causes torque to occur in a system? How is torque different from force?
2. How does the distance between the point of rotation (fulcrum) and the point of application of force affect the torque?

Worked Example 4.7

The biceps muscle exerts a vertical force on the lower arm, bent as shown in figure. For each case, calculate the torque about the axis of rotation through the elbow joint, assuming the muscle is attached 5 cm from the elbow as shown.

Data:

$$F = 700 \text{ N}$$

$$r_{\perp} = 5 \text{ cm} = 0.05 \text{ m}$$

Solution: Step 1:

$$(a) \tau = r_{\perp} F = 700 \times 0.05 = 35 \text{ N.m}$$

Step 2:

$$(b) \tau = r_{\perp} F = r \sin \theta F$$

$$\tau = (0.05) \sin 60^{\circ} \times 700$$

$$\tau = 30 \text{ N.m}$$



The arm exerts less torque at this angle than when it is at 90° . Weight machines at gyms are designed on these parameters.

4.6.2 Derivation a relation torques, moment of inertia and angular acceleration.

Consider a particle of mass m rotating in a circle of radius r at the end of a string whose mass is negligible as compared to mass of string. Assume that a single force F acts on mass as shown in figure: 4.20. The torque gives rise to the angular acceleration is $\tau = r F$.

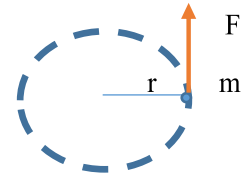

Fig: 4.20

Newton's second law of motion is $F = m a$,

Tangential linear acceleration $a_{tan} = r \alpha$

Equation ... can be rewritten as

$$\vec{F} = m r \alpha$$

$$r \vec{F} = m r^2 \alpha$$

$$\tau = I \alpha$$

$$\tau \propto \alpha$$

We have a direct relation between the angular acceleration and the applied torque where as mr^2 is representing rotational inertia which is called moment of inertia.

Now let us consider a rotating rigid object, such as wheel rotating about an axis through its center, which could be an axle. We can think of the wheel as containing of many particles located at various distances from the axis of rotation. We can apply eq.... to each particle of the object, and then sum over all the particles. The sum of the various torques is just the total torque, we get

$$\Sigma \tau = (\Sigma mr^2) \alpha$$

If each particle is assigned a number (1,2,3, 4....), then

$$I = \Sigma mr^2 = m_1 r_1^2 + m_2 r_2^2 + m_3 r_3^2 + \dots$$

By combining equations we get

$$\Sigma \tau = I \alpha \dots(4.22)$$

This is rotational equivalent of Newton's Second law. It is valid for the rotation of a rigid bodies about a fixed axis.

DO YOU KNOW?

Just as planets fall around the sun, stars fall around the centers of galaxies. Those with insufficient tangential speeds are pulled into, and are gobbled up by, the galactic nucleus – usually a black hole.

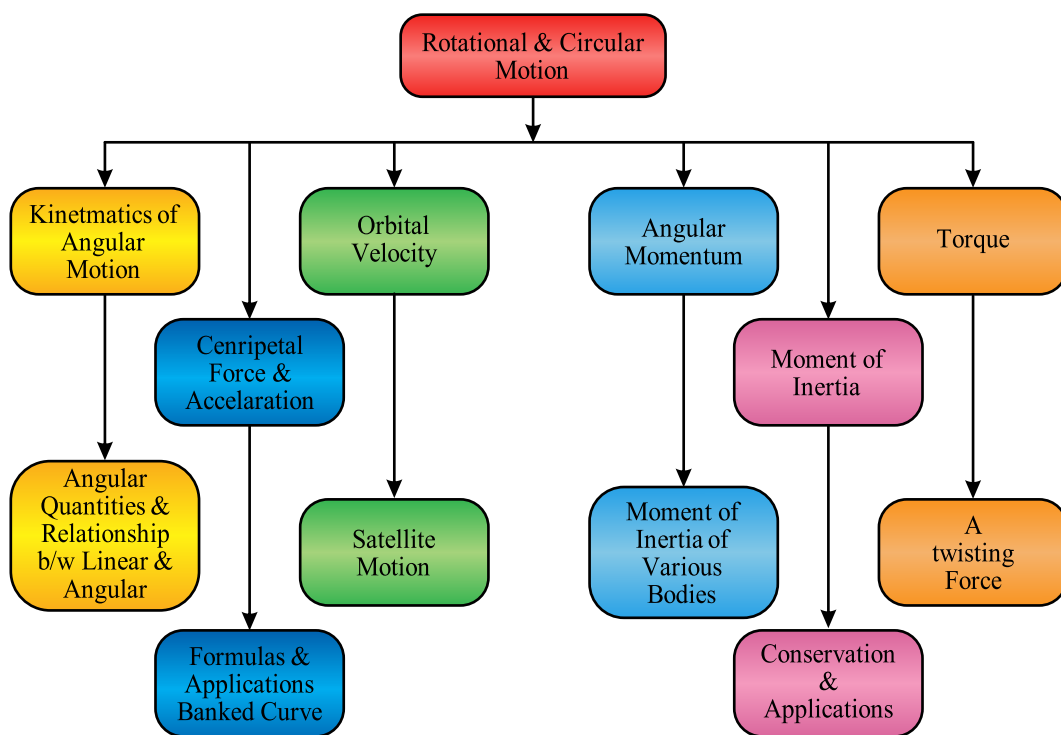



SUMMARY

- Angular displacement is the ratio of two lengths: the length of the arc and the radius of a circle.
- Angular velocity is the rate of change of angular displacement
- Angular acceleration is the rate of change of angular velocity.
- The force which causes the acceleration is directed towards the center of the circle and is called a centripetal force.
- The acceleration of an object moving in a circle, directed towards the center.
- A curve in a road that is sloping in a manner that helps a vehicle negotiate the curve.
- Orbital velocity is the speed required to achieve orbit around a celestial body, such as a planet or a star. Moment of inertia is the property of the body by virtue of it resists angular acceleration, which is the sum of the products of the mass of each particle in the body with the square of its distance from the axis of rotation.
- The moment of inertia of a body about an axis parallel to the body passing through its center is equal to the sum of moment of inertia of the body about the axis passing through the center and product of the mass of the body times the square of the distance between the two axes.
- The angular momentum, of a point particle is the vector product of its position / moment arm and linear momentum.
- The law of conservation of angular momentum states that when no resultant external torque acts on a body, its angular momentum remains constant.
- The turning effect of the force about the axis of rotation is called torque.
- Static torque is which does not produce an angular acceleration.
- Dynamic torque is that in which angular acceleration is produced.



Section (A): Multiple Choice Questions (MCQs)

- One radian is about
 - 25°
 - 37°
 - 45°
 - 57°
- Wheel turns with constant angular speed then:
 - each point on its rim moves with constant velocity
 - each point on its rim moves with constant acceleration
 - the wheel turns through equal angles in equal times
 - the angle through which the wheel turns in each second increases as time goes on
 - the angle through which the wheel turns in each second decreases as time goes on
- The rotational inertia of a wheel about its axle does not depend upon its
 - diameter
 - mass
 - distribution of mass
 - speed of rotation
- A force with at given magnitude is to be applied to a wheel. The torque can be maximized by
 - applying the force near the axle, radially outward from the axle.
 - applying the force near the rim, radially outward.
 - applying the force near the axle, parallel to a tangent to the wheel.
 - applying the force at the rim, tangent to the rim
- An object rotating about a fixed axis, I is its rotational inertia and α is its angular acceleration. Its
 - is the definition of torque
 - is the definition of rotational inertia
 - is definition of angular acceleration
 - follows directly from Newton's second law.
- The angular momentum vector of Earth about its rotation axis, due to its daily rotation is, directed
 - tangent to the equator towards east
 - tangent to the equator towards the west
 - north
 - towards the Sun.
- A stone of 2 kg is tied to a 0.50 m long string and swung around a circle at angular velocity of 12 rad/s . The net torque on the stone about the center of the circle is
 - 0 N.m
 - 6 N.m
 - 12 N.m
 - 72 N.m
- A man, with his arms at his sides, is spinning on a light frictionless turntable . When he extends his arms
 - his angular velocity increases
 - his angular velocity remains same
 - his rotational inertia decreases
 - his angular momentum remains the same.

9. A space station revolves around the earth as a satellite, 100 km above the Earth's surface. What is the net force on an astronaut at rest inside the space station?
 - a) equal to her weight on earth
 - b) a little less than her weight on earth
 - c) less than half her weight on earth
 - d) zero (she is weightless)
10. If the external torque acting on a body is zero, then its
 - a) angular momentum is zero
 - b) angular momentum is conserved
 - c) angular acceleration is maximum
 - d) rotational motion is maximum

Section (B): Structured Questions

CRQ:

1. For an isolated rotating body, what is the relation between angular velocity and radius?
2. When the moment of inertia of a rotating body is halved, then what will be the effect on angular velocity?
3. Compare kinematics equation of linear motion and circular motion
4. Can a small force ever exert a greater torque than a larger force? Give reason.
5. Give two real world applications of angular momentum
6. Derive relationship between torque and angular acceleration.
7. List the moment of inertia dependent factors.

ERQ

1. State and explain the law of conservation of angular momentum. Give two examples to illustrate it.
2. Discuss forces action on banked curve and derive relation between curve angle and velocity?
3. Derive the formula for centripetal acceleration using fundamental principles and equations, illustrating each step of the derivation
4. Derive the formula for the moment of inertia of a uniform rod or a solid sphere. Clearly illustrate each step of the derivation.
5. Define torque and explain how does it differ from force in linear motion?

Numericals:

1. A car mechanic applies a force of 800 N to a wrench for the purpose of loosening a bolt. He applies the force which is perpendicular to the arm of the wrench. The distance from the bolt to the mechanic's hand is 0.40 m. Find out the magnitude of the torque applied?
(320 N .m)
2. A car accelerates uniformly from rest and reaches a speed of 22 m/s in 9 s. If the diameter of a tire is 58 cm, find
 - (a) the number of revolutions the tire makes during this motion, assuming no slipping, and
 - (b) the final rotational speed of the tire in revolutions per second. (55 rev, 12 rev /s)

Unit 4: Rotational and Circular Motion

- An ordinary workshop grindstone has a radius of 7.5 cm and rotates 6500 rev/min.
 - Calculate the magnitude of centripetal acceleration at its edge in m/s^2 and convert it into multiples of g .
 - What is the linear speed of a point on its edge?
($3.47 \times 10^4 \text{ m/s}^2$, $3.55 \times 10^3 g$, 51 m/s)
- A satellite is orbiting the Earth with an orbital velocity of 3200 m/s. What is the orbital radius?
($3.897 \times 10^7 \text{ m}$)
- A satellite wishes to orbit the earth at a height of 100 km (approximately 60 miles) above the surface of the earth. Determine the speed, acceleration and orbital period of the satellite. (Given: $M_{\text{earth}} = 5.98 \times 10^{24} \text{ kg}$, $R_{\text{earth}} = 6.37 \times 10^6 \text{ m}$)
($7.85 \times 10^3 \text{ m/s}$, 9.53 m/s^2 , 1.44 hours)
- A thin disk with a 0.3m diameter and a total moment of inertia of $0.45 \text{ kg} \cdot \text{m}^2$ is rotating about its center of mass. There are three rocks with masses of 0.2kg on the outer part of the disk. Find the total moment of inertia of the system? ($0.464 \text{ kg} \cdot \text{m}^2$)
- What is the ideal banking angle for a gentle turn of 1.20 km radius on a highway with a 105 km/h speed limit (about 65 mi/h), assuming everyone travels at the limit? (4.14°)
- A 1500-kg car moving on a flat, horizontal road negotiates a curve as shown in Figure. If the radius of the curve is 35 m and the coefficient of static friction between the tires and dry pavement is 0.523, find the maximum speed the car can have and still make the turn successfully
(13.5 m/s)
- A system of points shown in figure 4.22. Each particle has same mass of 0.3 kg and they all lie in the same plane. What is the moment of inertia of the system about given axis?
(0.135 kg m^2)

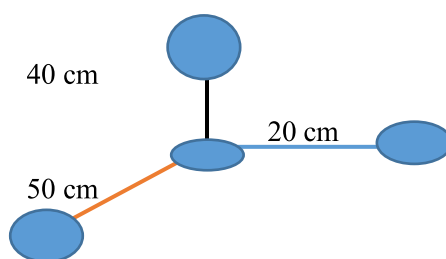

- What is the angular momentum of a 2.9 kg uniform cylindrical grinding wheel of radius 20 cm when rotating 1550 rpm?
 - How much torque is required to stop it in 6 s?
($9.5 \text{ kg} \cdot \text{m}^2/\text{s}^2$, $-1.6 \text{ N} \cdot \text{m}$)
- Determine the angular momentum of the Earth (a) about its rotation axis (Assume the Earth as uniform sphere), and (b) in its orbit around the Sun (Take Earth as a particle orbiting the Sun). The Earth has mass $6 \times 10^{24} \text{ kg}$ and radius $6.4 \times 10^6 \text{ m}$, and is $1.5 \times 10^8 \text{ km}$ from the Sun.
($7.3 \times 10^{33} \text{ kg} \cdot \text{m}^2/\text{s}$, $2.7 \times 10^{40} \text{ kg m}^2/\text{s}$)



Under-13 girls football tournament at Thar Coal Block II, Islamkot

In this unit student should be able to:

- Describe the concept of work in terms of the product of force F and displacement d in the direction of force (Work as scalar product of F and d).
- Distinguish between positive, negative and zero work with suitable examples.
- Calculate the work done from the force-displacement graph.
- Define work by variable force
- Calculate the work done from the force-displacement graph.
- Recall the concept of K.E
- Derive the equation of K.E by using $W = \mathbf{F} \cdot \mathbf{d}$
- Recall the concept of potential Energy.
- Derive the equation of P.E from $W = \mathbf{F} \cdot \mathbf{d}$.
- Show that the work done in gravitational field is independent of path.
- Calculate gravitational potential energy at a certain height due to work against gravity.
- Describe that the gravitational PE is measured from a reference level and can be positive or negative, to denote the orientation from the reference level.
- Use equations of absolute potential energy to solve problems.
- Explain the concept of escape velocity in term of gravitational constant G , mass m and radius of planet r .
- Express power as scalar product of force and velocity.
- Explain that work done against friction is dissipated as heat in the environment.
- State Work Energy theorem.
- Utilize work – energy theorem in a resistive medium to solve problems.
- State law of conservation of energy
- Explain Law of conservation of energy with the help of suitable examples.

5.1 Work:

Work is a very important physical concept in Physics, it has usually different meanings as used in our daily life. In Physics work can be defined as, when a force is applied on a body it produces the displacement in a body in the direction of force, then we can say work is done on a body. There are some few important examples in which there occurs no work done, like if a person holds a bucket vertically in a hand and displaces it horizontally then in this case work by the gravity is said to be zero, also if a person is circulating a body attached in a string, in which tension acts as a centripetal force, in this case work done on a body is also zero. In this chapter we will discuss about the answers of these questions.

5.1.1 Work done by a constant force:

If a force applied to an object does not change with respect to time, it is known as a constant force.

Work is measured by the product of the applied force and the displacement of the body in the direction of the force that is:

Work = (force) × (displacement in the direction of the force)

If a force F acting on a body produces a displacement s in the body in the direction of the force (Fig. 5.1(a)), then the work done by the force is given by:

$$W = F \cdot s \dots (5.1)$$

If the force F is making an angle θ with the direction of displacement of the body (Fig. 5.1(b)), then the work done is $w = (F \cos \theta) s = F s \cos \theta$ because $F \cos \theta$ is the component of F in the direction of displacement.

Note: The perpendicular component of force $F \sin \theta$ does no work on the cart.

Only horizontal component of force $F \cos \theta$ is responsible for work done on a body.

- Work can also be defined as the scalar or dot product of two parallel vectors force and displacement, since it follows the laws of scalar product.
- Work is a scalar physical quantity. The Joule (J) is the SI unit of energy and work.
- Joule is defined as the amount of work done when a force of one newton (1 N) is applied over a distance of one meter (1 m) in the direction of the force. Mathematically, 1 joule is equal to 1 newton-meter (N·m).

OR

the amount of energy transferred or expended to move an object.

If a body moves through a displacement s while a constant force F acts on it in the same direction the work done by the force on the body is $W = Fs$.

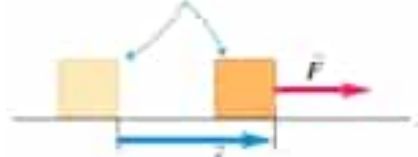

Fig: 5.1(a)



Fig: 5.1(b)

5.1.2 Different cases of work done by constant force:

i) Positive work:

If Force and displacement are in parallel to each other as shown in figure 5.2a work done on a body will be maximum.

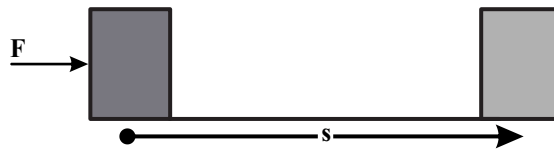

Fig: 5.2 (a)

$$W = Fs \cos \theta \quad \cos(0) = 1$$

$$W = Fs \cos 0$$

$$W = Fs$$

Example: Coolie pushing a load horizontally

ii) Zero work: If Force and displacement are mutually perpendicular to each other as shown in figure 5.2b work done on a body will be zero.

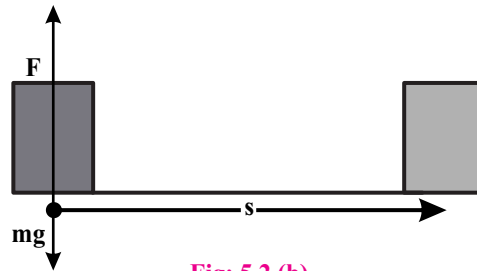

Fig: 5.2 (b)

$$W = Fs \cos \theta \quad \cos(90) = 0$$

$$W = Fs \cos 90$$

$$W = 0$$

Example:

1. Work done by a centripetal force is always zero, in this case tangential displacement and centripetal force are mutually perpendicular with each other hence work done on a body will be zero.
2. Coolie carrying a load on his head and moving horizontally with constant velocity. Then he applies force vertically to balance weight of body & its displacement is horizontal.

iii) Negative Work: If Force and displacement are in anti-parallel direction the work done on a body will be negative.

$$W = Fs \cos \theta \quad \cos(180) = -1$$

$$W = Fs \cos 180$$

$$W = -Fs$$

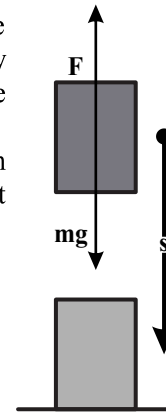

Fig: 5.2 (c)

Example: Work done on a body against gravitational field is negative, in this case a body is being displaced against the gravitational force as shown in figure 5.2c, hence displacement vector and force are anti-parallel to each other so work done on a body will be negative.

5.1.3 Work done by constant displacement time graph:

To calculate the work done by a force-displacement graph, you need to find the area under the graph. The area represents the work done.

If the force-displacement graph is a straight line as depicted in figure 5.3, the work done can be calculated using the formula:

$$\text{Work} = \text{Force} \times \text{Displacement}$$

where the force is constant along the line.

However, if the graph is not a straight line as shown in figure 5.4 A, you will need to break the area under the graph into smaller shapes (e.g., rectangles, triangles) and calculate the area of each shape separately. Then, you sum up the areas of all the shapes to find the total work done.

Here's a step-by-step process to calculate the work done by a force-displacement graph when it's not a straight line:

Divide the graph into smaller shapes, such as rectangles or triangles, by drawing lines perpendicular to the displacement axis as represented in figure 5.4 B.

Calculate the area of each shape separately. For triangles, the area is given by the formula:

$$\text{Area} = \frac{1}{2} \times \text{Force} \times \text{Displacement}$$

$$A = \frac{1}{2} \times F \cdot d \dots\dots(5.2)$$

For rectangles, the area is given by the formula:

$$\text{Area} = \text{Force} \times \text{Displacement}$$

Calculate the area for each shape and write it down.

Sum up the areas of all the shapes to find the total work done.

$$\text{Total Work} = \text{AreaI} + \text{AreaII} + \text{AreaIII}$$

By following this process, we can calculate the work done by a force-displacement graph that is not a straight line.

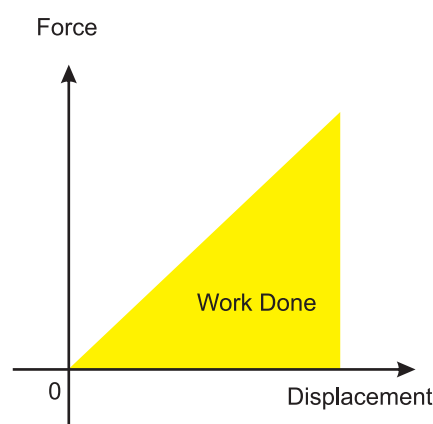

Fig: 5.3

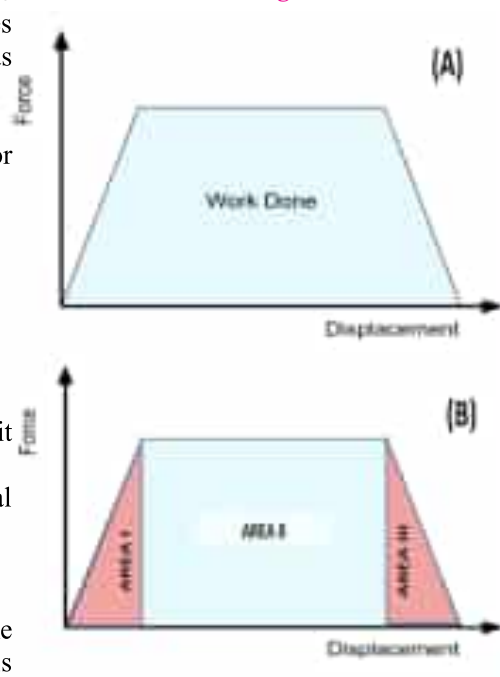

Fig: 5.4

Constant force displacement graph

Worked Example 5.1

Calculate the work done from the following force-displacement graph.

Solution:

Step 1: Write the known quantities and point out

Force $F = 4\text{N}$

Base of Area I = 4m

Base of Area II = 8m

Base of Area III = 4m

Step 2: Write the formula and rearrange if necessary



Area II = Area of rectangle = Force \times displacement

Area I & III = Area of triangle = $\frac{1}{2} \times$ Force \times Displacement

Total workdone = Area I + Area II + Area III

Step 3: Put the value in formula and calculate

Total workdone = $W_T =$ Area I + Area II + Area III

$$W_T = \frac{1}{2} \times \text{Force} \times \text{Displacement} + \text{Force} \times \text{displacement} + \frac{1}{2} \times \text{Force} \times \text{Displacement}$$

$$W_T = \frac{1}{2} \times 4\text{N} \times 4\text{m} + 4\text{N} \times 8\text{m} + \frac{1}{2} \times 4\text{N} \times 4\text{m}$$

$$W_T = 8\text{N.m} + 32\text{N.m} + 8\text{N.m} = 48\text{N.m}$$

$$W_T = 48\text{J}$$

Self-Assessment Questions:

1. When does work have a positive value, and when does it have a negative value? Provide examples of each case.
2. In what units is work typically measured, and how are these units related to force and displacement?

5.2 Work done by variable force

Force varying with displacement

A variable force is a force that changes in magnitude or direction as a function of time, position, or any other relevant variable. Unlike a constant force, which remains unchanged, a variable force can have different values at different points or moments.

In this condition we consider the variable force to be variable for any elementary displacement ds as shown in figure 5.5, and work done in that elementary displacement is evaluated. Total work is obtained by integrating the elementary work from initial to final limits.

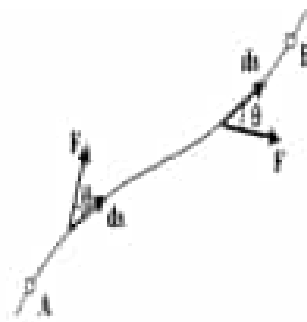

Fig: 5.5 Variable force

$$\Delta W = \vec{F} \cdot \overrightarrow{\Delta s}$$

$$\Delta W = \sum \vec{F} \cdot \overrightarrow{\Delta s} \dots\dots (5.3)$$

Variable forces can arise in various situations and fields of study. Here are a few examples: Spring Force, Frictional Force etc.

Work done by variable force and its graphical calculation:

Consider a body covers displacement from x_i to x_f , when a variable force acts on it. To clarify the situation, we plot the graph between force and displacement covered by the body as shown in figure; 5.6 (a and b).

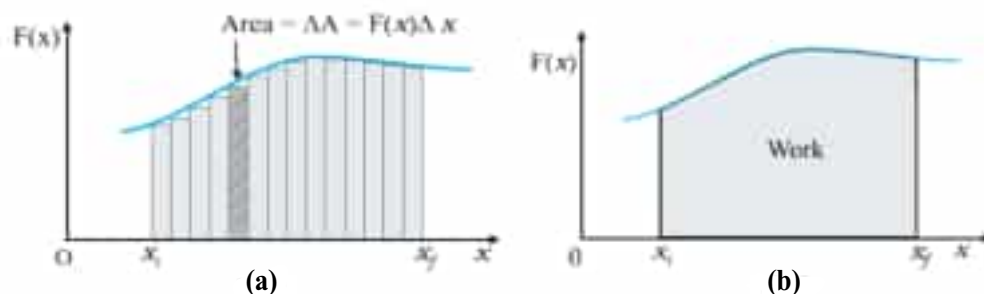

Fig: 5.6 (a and b) variable force displacement graph

the area under the covered line is representing the work done by the body. To calculate the work done by the body we divide the covered displacement into small segments

$\Delta x_1, \Delta x_2, \Delta x_3 \dots \Delta x_n$ and the corresponding forces for each segment are

$\vec{F}_{x1}, \vec{F}_{x2}, \vec{F}_{x3} \dots \vec{F}_{xn}$ as shown in figure 5.6.

We know the work done for each segment will be $W_1, W_2, W_3, \dots W_n$.

The total work done in this case will be $W_T = W_1 + W_2 + W_3 + \dots W_n = \sum_{i=1}^n W_i$

$$W_T = \vec{F}_{1x} \cdot \overrightarrow{\Delta x_1} + \vec{F}_{2x} \cdot \overrightarrow{\Delta x_2} + \vec{F}_{3x} \cdot \overrightarrow{\Delta x_3} + \dots + \vec{F}_{xn} \cdot \overrightarrow{\Delta x_n} = \sum_{i=1}^n \vec{F}_{xi} \cdot \overrightarrow{\Delta x_i}$$

$$W_T = \sum_{i=1}^n \vec{F}_{xi} \cdot \overrightarrow{\Delta x_i} = F_i \cos \phi \Delta x_i \dots (5.4)$$

Above equation represents the total work done by body when variable force acts on it.

Self-Assessment Questions:

1. How does the concept of work done by a variable force differ from work done by a constant force?
2. How can you represent a variable force graphically to analyze the work done?

5.3 Kinetic energy:

The faster the object moves, the greater is its kinetic energy when the object is stationary its kinetic energy is zero. (The energy possessed by a body by virtue of its motion called kinetic energy)

To find an expression for K.E of an object in motion, we must calculate the work done by the object. This work done must be equal to the change in K.E of the object

Suppose a force is applied on an object and it produces displacement in the direction of force along x-axis as depicted in figure 5.7

Hence work is done on a body which is stored in the form of kinetic energy in a body which is calculated as:

$$\begin{aligned} \text{Work done by the body } W &= \vec{F} \cdot \vec{S} = FS \cos \theta && \left[\begin{array}{l} \theta = 0 \\ \cos(0) = 1 \end{array} \right] \\ &= F.S \cos \theta \\ &= F.S \\ W &= F.S && \therefore (F = ma) \\ W &= ma.S \longrightarrow (i) \end{aligned}$$

By using the 3rd equation of motion ($vf^2 - vi^2 = 2as$). We take the value of s by introducing the initial conditions

$$(v_i = 0, v_f = v)$$

$$v^2 - 0 = 2as$$

$$s = \frac{v^2}{2a} \text{ put this value in equation (i)}$$

$$W = ma \cdot \frac{v^2}{2a} = \frac{1}{2}mv^2$$

$$K.E = \frac{1}{2}mv^2 \dots\dots(5.5)$$

This is an expression for Kinetic energy of a body.

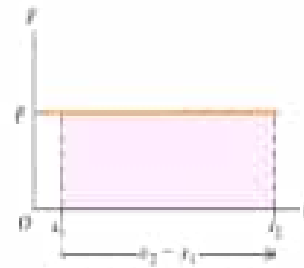

Fig: 5.7

Worked Example 5.2

A car with a mass of 1,200 kg is traveling at a velocity of 25 m/s. Calculate the kinetic energy of the car.

Solution:

Step 1:

Mass (m) = 1,200 kg

Velocity (v) = 25 m/s

Step 2:

The formula for kinetic energy is given by:

$$\text{Kinetic Energy } K.E = \frac{1}{2}mv^2$$

Step 3:

Substituting the given values into the formula:

$$K.E = \frac{1}{2}(1200)(25)^2$$

$$= 375,000 \text{ Joules}$$

Therefore, the kinetic energy of the car is 375,000 Joules.

Self-Assessment Questions:

1. How does the kinetic energy of an object change when its mass or velocity changes?
2. Can an object have a negative kinetic energy? Explain your answer.

5.4 Potential energy:

- How do energy concepts apply to the descending duck?
- We will see that we can think of energy as being stored and transformed from one form to another

When work is done on a body against any field/ force, an energy is stored in a body called potential energy. When a body of mass “m” is lifted to a height “h” against the gravitational force (mg), work is done on it. This work is stored in it in the form of gravitational potential energy. “The energy possessed by a body by virtue of its position is called potential energy P.E”.

Gravitational potential energy:

When work is done on a body against the gravitational force of an earth from y_1 level to y_2 level:

$$W_{grav} = Fs = -mg (y_1 - y_2)$$

$$W_{grav} = mgy_1 - mgy_2$$

$$W_{grav} = mgh \dots\dots (5.6)$$

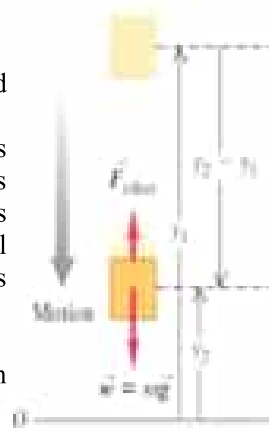

Fig: 5.8

Hence Potential energy is stored in a body when work is done against gravitational force of an earth so:

$$P.E = mgh$$

Thus, potential energy of a body in the earth’s gravitational field at a height “h” is “mgh” which is positive quantity with respect to earth’s surface which is supposed to be the level of an arbitrary zero potential.

Self-Assessment Questions:

1. What factors determine the gravitational potential energy of an object in a given situation?
2. Can an object have negative potential energy? Explain your answer.

5.5 Work done against gravitational field:

Consider a body of mass ‘m’ which is taken every slowly to small height ‘h’ in the gravitational field such as that the acceleration of the body is zero. The work done in moving the body is given by:

$$Work\ done = F_{ex} h = F_g h \cos \theta \dots\dots(5.7)$$

Where ‘ F_{ex} ’ is the external force applied on the body . Since the external force applied on the body and the displacement are along the same direction, therefore work done by external force ‘ W_{ex} ’ is given by :

$$W_{ex} = F_{ex}h \dots\dots\dots(Cos \theta^o = 1)$$

As the acceleration of the body is zero therefore magnitude of external force is equal to that of the force of gravity i.e.

$$F_{ex} = mg$$

Therefore $W_{ex} = mgh$ -----(5.8)

Work done 'Wg' by the gravitational force 'Fg' is given by

$$W_g = \vec{F}_g \cdot \vec{h} = F_g \cdot h \cos 180^\circ$$

$W_g = -F_g \cdot h \quad \therefore \vec{F}_g$ and \vec{h} are in opposite direction then angle between them is 180

Since $F_g = mg$

$$W_g = -mgh$$

OR $-W_g = mgh$ -----(5.9)

Comparing eq (5.8) and (5.9)

$$W_{ex} = -W_g$$

By putting the value of Wg from eq. (5.9), we get

$$W_{ex} = -W_g = (-mgh) = mgh \dots\dots(5.10)$$

This work done on the body by an external force against the gravitational force is stored in the form of potential energy and is known as gravitational potential energy represented by U_g

Therefore $U_g = W_{ex} = -W_g = mgh \dots\dots(5.11)$

This gravitational potential energy is the relative potential energy of the body with respect to some arbitrary zero level..

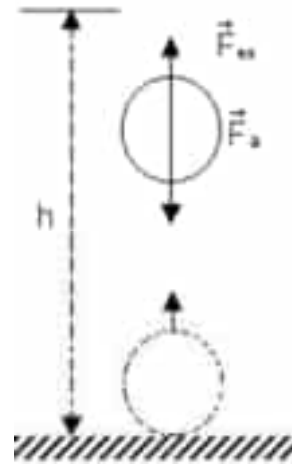

Fig: 5.9

Workdone in gravitational field is independent of path:

To prove the statement that the work done in the gravitational field is independent of path. Lets us take a closed triangular path ABC in gravitational field shown in Fig: for simplicity the base BC is taken perpendicular to the gravitational force "mg" initially the body is at A.

$$W_{A \rightarrow B} = \vec{F} \cdot \vec{S}_1 = F \cdot S_1 \cos \alpha = Fh \quad \therefore S_1 \cos \alpha = h$$

$$W_{A \rightarrow B} = mgh \quad \therefore F = mg$$

$$W_{B \rightarrow C} = \vec{F} \cdot \vec{S}_2 \quad \therefore \cos 90^\circ = 0$$

$$W_{B \rightarrow C} = F \cdot S_2 \cos 90^\circ = 0$$

$$W_{C \rightarrow A} = \vec{F} \cdot \vec{S}_3 = F \cdot S_3 \cos (180 - \beta)$$

$$\rightarrow F \cdot S_3 (-\cos \beta) \quad \therefore S_3 \cos \beta = h$$

$$= -F \cdot S_3 \cos \beta \quad \therefore F = mg$$

$$= -mgh$$

Thus, total work done along path A BCA

$$= (mgh) + (0) - (mgh)$$

$$= 0$$

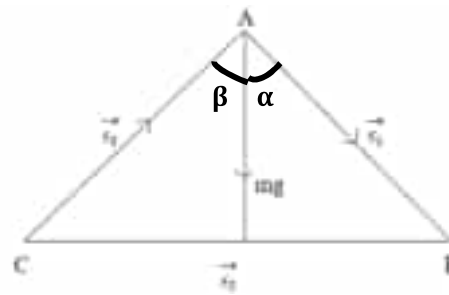

Fig: 5.10

Thus, either the body is moved from A to B and B to C or it is moved directly from A to C, in both the cases the work done is same, such type of field or force in which the work done is independent of path is called conservative field and in conservative field work done in a closed path is always zero.

Self-Assessment Questions:

1. When is the work done against a gravitational field positive, and when is it negative? Provide examples for each case.
2. How does the work done against gravity affect the potential energy of an object?

5.6 Absolute gravitational potential energy:

Absolute potential energy at a point is the amount of work done in moving a body from infinity to that point.

Expression for absolute gravitational potential energy:

Consider a body of mass 'm' at point A (1) in the gravitational field. If the body is lifted to a far point B ('n') in the gravitational field then work done in moving body can not be directly found using the formula:

$$\text{Work done} = \text{Force} \times \text{displacement}$$

Because the gravitational force will not remain constant for such a large distance.

To overcome this difficulty, divide the distance between A and B into large number of intervals each of width Δr . Δr is so small that the gravitational force through out this interval may be assumed to be constant.

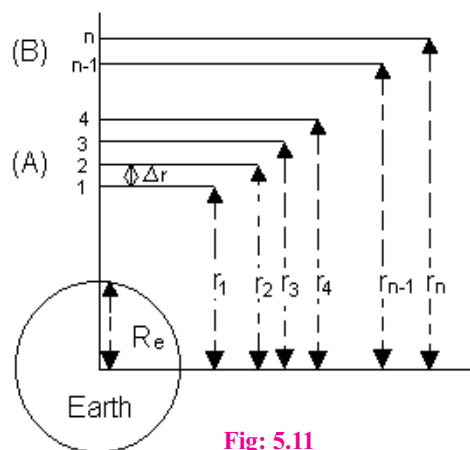

Fig: 5.11

If \vec{F} be the gravitational force on the body at point 1 then magnitude is given by:

$$F_1 = \frac{GmM_e}{r_1^2}$$

Where G = Gravitational constant

M_e = Mass of earth and

R_1 = Distance of point 1 from the center of the earth.

Similarly if r_2 be the gravitational force on the body at point 2 then its magnitude is given by:

$$F_2 = \frac{GmM_e}{r_2^2}$$

Where r_2 = Distance of point 2 from the centre of the earth.

The magnitude of the average force \vec{F} acting through out the first interval is give by:

$$F = \frac{F_1 + F_2}{2}$$

$$F = \frac{\left(\frac{GmM_e}{r_1^2}\right) + \left(\frac{GmM_e}{r_2^2}\right)}{2} = \frac{1}{2} \left[\frac{GmM_e}{r_1^2} + \frac{GmM_e}{r_2^2} \right]$$

Or
$$F = \frac{GmM_e}{2} \left[\frac{1}{r_1^2} + \frac{1}{r_2^2} \right] = \frac{GmM_e}{2} \left[\frac{r_2^2}{r_1^2 r_2^2} + \frac{r_1^2}{r_1^2 r_2^2} \right]$$

But $r_2 - r_1 = \Delta r$ -----(i)

Therefore $r_2 = r_1 + \Delta r$ ----- (ii)

Thus
$$F = \frac{GmM_e}{2} \left[\frac{(r_1 + \Delta r)^2 + r_1^2}{r_1^2 r_2^2} \right]$$

$$F = \frac{GmM_e}{2} \left[\frac{r_1^2 + 2r_1\Delta r + (\Delta r)^2 + r_1^2}{r_1^2 r_2^2} \right]$$

As Δr is very small, therefore $(\Delta r)^2$ is negligible small

Therefore
$$F = \frac{GmM_e}{2} \left[\frac{2r_1^2 + 2r_1\Delta r}{r_1^2 r_2^2} \right]$$

$$F = \frac{GmM_e}{r_1^2 r_2^2} \text{ -----(5.12)}$$

Work done in lifting the body from point '1' to '2' given by:

$$W_{1 \rightarrow 2} = \vec{F} \cdot \vec{\Delta r} = F\Delta r \cos \theta$$

Since \vec{F} and Δr are along the same direction.

Unit 5: Work, Energy and Power

Therefore $\theta = 0^\circ$ and $\cos 0^\circ = 1$

Therefore $W_{1 \rightarrow 2} = F \Delta r$

By putting the values of ' Δr ' and ' F ' from eq (i) and (iii) , we get.

$$\begin{aligned} W_{1 \rightarrow 2} &= \frac{GmM_e}{r_1 r_2} (r_2 - r_1) = GmM_e \left(\frac{r_2 - r_1}{r_1 r_2} \right) \\ &= GmM_e \left(\frac{r_2}{r_1 r_2} - \frac{r_1}{r_1 r_2} \right) \end{aligned}$$

$$W_{1 \rightarrow 2} = GmM_e \left(\frac{1}{r_1} - \frac{1}{r_2} \right) \dots \dots (5.13)$$

Similarly the work done in lifting the body from point 2 to 3 , 3 to 4 ----- and($n - 1$) to n is given by :

$$W_{2 \rightarrow 3} = GmM_e \left(\frac{1}{r_2} - \frac{1}{r_3} \right)$$

$$W_{3 \rightarrow 4} = GmM_e \left(\frac{1}{r_3} - \frac{1}{r_4} \right)$$

$$W_{(n-1) \rightarrow n} = GmM_e \left(\frac{1}{r_{n-1}} - \frac{1}{r_n} \right)$$

The total work done in lifting the body from '1' to 'n' is given by:

$$W = W_{1 \rightarrow 2} + W_{2 \rightarrow 3} + W_{3 \rightarrow 4} + \dots \dots W_{(n-1) \rightarrow n}$$

Or
$$W = GmM_e \left(\frac{1}{r_1} - \frac{1}{r_n} \right)$$

This work done is stored in the body as potential energy.

Thus P.E of the body at B with respect to point A

$$P.E = GmM_e \left(\frac{1}{r_1} - \frac{1}{r_n} \right)$$

The P.E of the body at point A with respect to point B is

$$\Delta U = -W$$

Or
$$\Delta U = -G m M_e \left(\frac{1}{r_1} - \frac{1}{r_n} \right)$$

If the point 'B' lies at infinity then $r_n = \infty$ and $\frac{1}{\infty} = 0$

Therefore
$$\Delta U = -GmM_e \left(\frac{1}{r_1} \right)$$

This P.E of the body at point 'A' is called Absolute potential energy.

$$\Delta U = (P.E)_{abs}$$

Therefore

$$(P.E)_{abs} = -\frac{GmM_e}{r_1}$$

If 'R_e' be the radius of the earth then the absolute potential energy of the body at the surface of the earth is given by:

$$(P.E)_{abs} = -\frac{GmM_e}{R_e} \dots\dots(5.14)$$

Absolute potential energy at certain height:

The absolute potential energy of the body at a certain height 'h' ($h \ll R_e$) above the surface of the earth is given by:

$$(P.E)_{abs} = -\frac{GmM_e}{R_e + h} = \frac{-GmM_e}{R_e \left(1 + \frac{h}{R_e} \right)}$$

$$(P.E)_{abs} = -\frac{GmM_e}{R_e} = \left(1 + \frac{h}{R_e} \right)^{-1}$$

Using Binomial theorem, we can write

$$\left(1 + \frac{h}{R_e} \right)^{-1} = 1 + \frac{(-1) h}{1 R_e} + \frac{(-1)(-2)}{2!} \left(\frac{h}{R_e} \right)^2 + \dots$$

$$= 1 - \frac{h}{R_e} + \left(\frac{h}{R_e}\right)^2 + \dots$$

Since $h \ll R_e$. Therefore we can neglect the terms containing the higher powers of $\frac{h}{R_e}$

Therefore
$$\left(1 + \frac{h}{R_e}\right)^{-1} = 1 - \frac{h}{R_e}$$

Thus
$$(P.E)_{\text{abs}} = \frac{GmM_e}{R_e} = \left(1 - \frac{h}{R_e}\right) \dots \dots (5.15)$$

Worked Example 5.3

The mass of the earth is 5.98×10^{24} kg and the mass of the sun is 1.99×10^{30} kg, and the earth is 160 million km away from the sun, calculate the GPE of the earth.

Data:

the mass of the Earth (m) = 5.98×10^{24} kg and mass of the Sun (M)
 $M = 1.99 \times 10^{30}$ kg

Solution:

Step 1: The gravitational potential energy is given by:

$$U = \frac{-GMm}{r}$$

Step 2:
$$U = \frac{6.673 \times 10^{-11} \times 5.98 \times 10^{24} \times 1.99 \times 10^{30}}{160 \times 10^9}$$

$$U = 4963 \times 10^{30} \text{ J}$$

Self-Assessment Questions:

1. In what scenarios is the absolute gravitational potential energy of an object considered zero, and why?
2. What happens to the absolute gravitational potential energy of an object as it moves higher or lower in a gravitational field?

5.7 Escape velocity:

Escape velocity on earth or any other planet is defined as the minimum velocity with which the body has to be projected vertically upwards from the surface of the earth or any other planet so that it just crosses the gravitational field of earth or of that planet and never return on its own.

Work is done at the cost of kinetic energy given to the body at the surface of earth. If V_{es} is the escape velocity of the body projected from the surface of earth. Then kinetic energy of the body. M and R

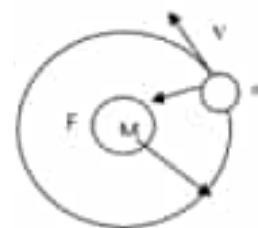

Fig: 5.12

are the mass and Radius of the earth respectively the body will escape out of the gravitational field.

$$\frac{1}{2} m v_{es}^2 = GMm/R$$

$$V_{es} = \sqrt{2Gm/R} \quad (i)$$

$$g = GM/R^2$$

Putting in equation (i) $GmM = gR^2$

$$V_{es} = \sqrt{\frac{2gR^2}{R}}$$

$$V_{es} = \sqrt{2gR} \quad \dots\dots(5.16)$$

The value of v_{es} come out tube approximately 11.2 k ms^{-1} . The value of escape velocity depends upon mass and radius of the planet of the surface from which the body is to be projected, clearly the values of escape velocity of a body will be different for different planets.

5.8 Power:

Energy can be transferred from one object to another. If we are concerned about the measure of how fast energy is transferred, then the more energy transferred per second, the greater the power of the transfer process.

Power is the rate at which energy is transformed from one form to another or the work done per unit time.

$$\text{Power, } P(\text{watts}) = \frac{\text{Energy transfer or work done, } W \text{ (joules)}}{\text{Time taken, } t \text{ (seconds)}}$$

Where energy is transferred by a force doing work, the energy transferred is equal to the work done by the force. Therefore, the rate of transfer of energy is equal to the work per second. So, if the force does work W in time t , then

$$P = W/t$$

The power is the total work done divided by the total time interval.

$$P_{av} = \frac{\text{Total work}}{\text{Time interval}}$$

Let,

$$\text{Total work} = \Delta W$$

$$\text{Total work} = \Delta t$$

$$P_{av} = \frac{\Delta W}{\Delta t}$$

$$= \vec{F} \frac{\Delta s}{\Delta t}$$

$$P_{av} = \vec{F} \cdot \vec{V}_{av}$$

or

$$P_{av} = FV \cos\theta \dots (5.17)$$

Therefore the power can also be defined as the Scalar/dot product of force and velocity.

- It's a scalar physical quantity and follows the laws of scalar product.
- It's fundamental unit is watt.
- Its dimensions are $M L^2 T^{-3}$

5.8.2 Work done against friction is dissipated as heat in the environment:

No system is perfect. Whenever there is a change in a system, energy is transferred and some of that energy is dissipated.

A rise in temperature is caused by the transfer of wasteful energy in mechanical processes. The energy is dissipated into the system.

In a mechanical system, energy is dissipated when two surfaces rub together. Work is done against friction which causes heating of the two surfaces – so the internal (thermal) energy store of the surfaces increases and this is then transferred to the internal energy store of the surroundings.

There are many electrical appliances that are used in the home to transfer electrical energy to other useful forms. Every system will waste some energy, and so the useful and wasted energy can always be identified.

DO YOU KNOW?

1 watt = $1N \cdot 1m \cdot s^{-1}$
 Its units are Erg/sec (C.G.S)
 foot – pound/sec (F.P.S)
 and Joule/sec = watt (M.K.S or S.I)
 1 erg = 10^{-7} Joule
 1 Ft.lb/sec = 1.356 Watt
 1 Ft.lb/sec = 1.82×10^{-3} hp
 1hp = 746 watt
 $\frac{1}{2}$ hp = 373 watt

Appliance	Useful energy	Wasted energy
Electric kettle	Energy that heats the water.	Internal (thermal) energy heating the kettle. Infrared radiation transferred to the surroundings.
Hairdryer	Internal (thermal) energy heating the air. Kinetic energy of the fan that blows the air.	Sound radiation. Internal (thermal) energy heating the hairdryer. Infrared radiation transferred to the surroundings.
Lightbulb	Light radiation given out by the hot filament.	Infrared radiation transferred to the surroundings.
TV	Light radiation that allows the image to be seen. Sound radiation that allows the audio to be heard.	Internal (thermal) energy heating the TV set. Infrared radiation transferred to the surroundings.

Devices can be made to reduce the energy that they waste or 'dissipate' to the surroundings. One example is lubrication being used to reduce the friction between moving parts of a machine. This reduces the thermal energy transferred.

For systems that are designed to transfer thermal energy, the wasteful dissipation of thermal energy to the surroundings can also be reduced. This is often done by using thermal insulation, for example, making a kettle from plastic, which is a thermal insulator.

Self-Assessment Questions:

1. How does escape velocity relate to the kinetic energy and gravitational potential energy of an object?
2. How does increasing power affect the rate at which work is done or energy is transferred?

5.9 Work energy theorem:

It states that total work done on the body is equal to the change in kinetic energy. (Provided body is confined to move horizontally and no dissipating forces are operating).

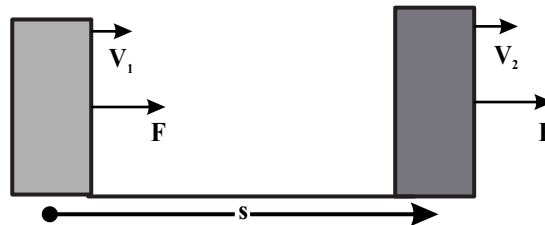

Fig: 5.13

Consider a body of mass m moving with initial velocity v_1 after travelling through displacement s its final velocity becomes v_2 under the effect of force F .

As we know that

$$2as = v_2^2 - v_1^2$$

$$a = \frac{v_2^2 - v_1^2}{2s}$$

hence external force acting on the body is

$$F = ma$$

$$F = m \frac{v_2^2 - v_1^2}{2s}$$

Therefore, work done on body by external force is

$$W = \vec{F} \cdot \vec{S}$$

$$W = m \frac{v_2^2 - v_1^2}{2s} \cdot s \cdot \cos(0)$$

$$W = \frac{1}{2} m v_2^2 - \frac{1}{2} m v_1^2$$

$$W = K.E_2 - K.E_1$$

$$W = \Delta K \dots(5.18)$$

Worked Example 5.4

A person riding their bike has a mass of 120 kg; they are riding at 10m/s. suddenly a dog crosses the road and to avoid hitting the dog the bicyclist brakes applying a braking force of 500 N for a distance of 10 meters. What is the final velocity of the bicyclist when they stop braking?

Step 1: Identify the mass of the object. The mass is 120 kilograms.

Step 2: Identify the initial velocity.

The initial velocity is 10m/s.

Step 3: Identify or calculate the work done on the object.

The force on the object is 500 newtons over a distance of 10 meters.

Since the force is a braking force it is resisting the motion of the object making the work done negative.

$$W = \vec{F} \times \Delta x = -500 \times 10 = -5,000 \text{ Joules}$$

Step 4: Identify or calculate the initial energy of the object.

Using the kinetic energy formula.

$$K.E_{\text{initial}} = \frac{1}{2}mv_{\text{initial}}^2$$

$$K.E_{\text{initial}} = \frac{1}{2}(120)(10)^2 = 6,000 \text{ Joules}$$

Step 5: Add the result from Step 4 with the result from Step 3.

$$6,000 \text{ Joules} + (-5,000 \text{ Joules}) = 1,000 \text{ Joules}$$

Step 6: Using the result from Step 5 equate it to the equation of kinetic energy and solve for velocity to receive the final velocity of the object.

$$K.E_{\text{final}} = 1,000 \text{ Joules}$$

$$\frac{1}{2}mv_{\text{final}}^2 = 1,000$$

$$\frac{1}{2}(120)v_{\text{final}}^2 = 1,000$$

$$v_{\text{final}} = \sqrt{16.7} = 4.1 \text{ m/s}$$

The final velocity of the bicyclist when they stop braking is 4.1m/s.

Self-Assessment Questions:

1. Explain how positive work and negative work contribute to changes in an object's energy according to the work-energy theorem.
2. Is the work-energy theorem valid only for conservative forces, or does it apply to non-conservative forces as well? Explain.

5.10 Transformation of energy:

Energy can neither be created nor destroyed. It can only be transformed from one form to another. A loss in one form of energy is accompanied by an equal increase in the other forms of energy. The total energy remains constant'.

According to Einstein's mass energy relation:

$E = mc^2$, energy can be converted into mass and mass can be converted to energy. Pair production is the example of conversion of energy into mass

On the other hand Nuclear fission and Fusion are examples of conversion of mass into energy.

5.10.1 Law of conservation of energy:

Consider a body of mass 'm' is placed at a point from the ground at certain height h.

$$\text{P.E of the body at P} = mgh$$

$$\text{K.E of the body at P} = 0$$

$$\text{Total energy of the body at P} = \text{K.E} + \text{P.E} = 0 + mgh$$

$$\text{Total energy at P} = mgh \text{ -----(i)}$$

If the body is allowed to fall freely under the action of gravity then its P.E will go on decreasing while its K.E will go on increasing just before hitting the ground the P.E of the body will be minimum or zero while K.E of the body will be maximum. If 'v' be the velocity of the body just before hitting the ground then K.E of the body = $\frac{1}{2} mv^2$

The velocity of the body can be found by formula:

$$2gh = V_f^2 - V_i^2$$

Where V_i = initial velocity at 'P' = 0

$$V_f = \text{final velocity at O} = v$$

$$\text{Therefore } 2gh = v^2 - 0^2$$

$$v^2 = 2gh$$

$$\text{K.E at O} = \frac{1}{2} m \times 2gh = mgh$$

$$\text{P.E at O (near the ground)} = 0$$

$$\text{Total energy of the body at point 'O'} = mgh \text{ -----(ii)}$$

If V be the velocity of the body at point 'Q' then

$$\text{K.E at Q} = \frac{1}{2} mv^2$$

$$\text{P.E at Q} = mgh (h-x) = mgh - mgx$$

V can be found by formula

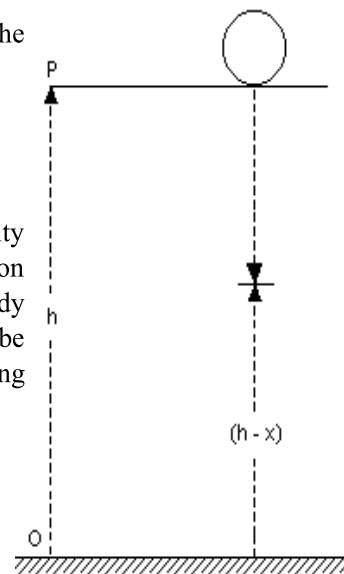

Fig: 5.14

Unit 5: Work, Energy and Power

$$2gh = V_f^2 - V_i^2$$

Where $V_i = 0$, $V_f = V$ and $h = x$

Therefore $2gx = (V)^2 - 0^2$

$$V^2 = 2gx$$

Therefore K.E at Q = $\frac{1}{2} m \times 2gx = mgx$

Total energy at Q = K.E + P.E
= $mgx + mgh - mgx$

Total energy at Q = mgx -----(iii)

From equation (i), (ii) and (iii) it can be seen that the total energy of the body remains constant everywhere provided there is no force of friction involved during the motion of the body.

If there is some force of friction acting on the body then a fraction of P.E. is lost in doing work against the force of friction, Thus,

Total energy = K.E + P.E + Loss of energy or work done against force of friction.

Examples of Conservation of energy:

1. When we switch on an electric bulb, we supply electrical energy to it which is converted into heat and light energies, i.e.

$$\text{Electrical Energy} = \text{Heat energy} + \text{Light energy}$$

2. Fossil fuels e.g. coal and petrol store chemical energy. When they burn, chemical energy is converted into heat energy, i.e.

$$\text{Chemical Energy} = \text{Heat energy} + \text{Losses}$$

3. The heat energy present in the steam boiler can be used to derive a steam engine. Here heat energy is converted into kinetic (mechanical energy), i.e.

$$\text{Heat Energy} = \text{Mechanical energy} + \text{Losses}$$

4. In rubbing our hands we do mechanical work which produces heat, i.e.

$$\text{Mechanical Energy} = \text{Heat energy} + \text{Losses}$$



SUMMARY

- Work is said to be done on a body, when a force is applied on a body and it produces displacement in a body in the direction of force.
- If force and displacement are parallel to each other work done will be positive.
- If force and displacement are perpendicular to each other work done will be zero.
- If force and displacement are anti Parallel to each other work done on a body will be negative.
- The energy possessed by a body due to its position/configuration is called potential energy.
- When work is done on a body against the gravitational force of an earth, an energy is stored in a body called gravitational potential energy.
- The work required to lift a body from a certain point in the gravitational field to infinity is called absolute potential energy.
- Minimum velocity required a body so that it emerges out from the gravitational field of an earth called escape velocity.
- The value of escape velocity of earth is 11.2 km/s.
- The time rate of doing work is called power.
- The work done in a closed path is always zero, this field is called conservative field.
- Electric field, gravitational field and magnetic field are conservative fields.
- Frictional force/ self-adjusting force is a non-conservative force in nature.
- Work done by centripetal force is always zero.
- The scalar/dot product of force and velocity of a body is called Mechanical Power.
- The ratio of output to input is called efficiency.
- Energy can neither be created nor destroyed but transform from one from to another form.

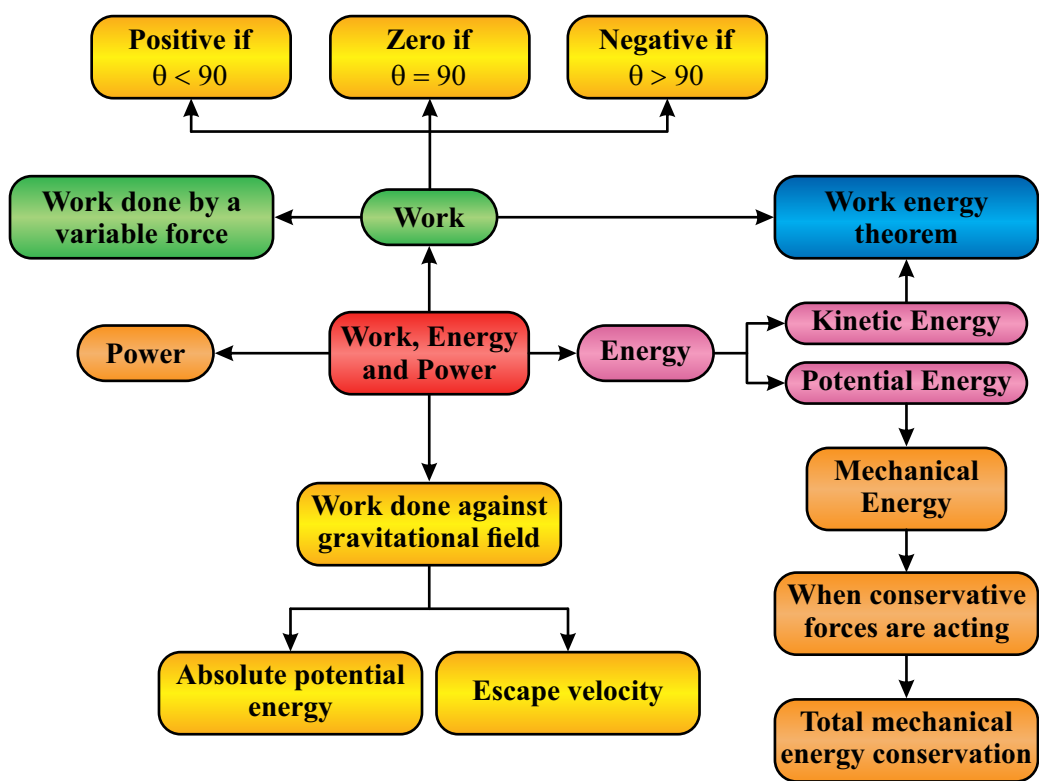



EXERCISE

Section (A): Multiple Choice Questions (MCQs)

- Work done by centripetal force is always:
 - Maximum
 - Minimum
 - Zero
 - None of these
- A body of mass 5 kg is moving with a momentum of 10 kg m/s . A force of 0.2 N acts on it in the direction of motion of the body for 10 seconds. The increase in kinetic energy is:
 - 2.8 J
 - 3.2 J
 - 3.8 J
 - 4.4 J
- The kinetic energy of a light and a heavy object is same. Which object has maximum momentum?
 - Light object
 - Heavy object
 - Both have same momentum
 - N.O.T
- Two bodies of mass 1 kg and 2 kg have equal momentum. Then the ratio of their kinetic energies is:
 - 2 :1
 - 3:1
 - 1 :3
 - 1:1
- A body fallen from height h . After it has fallen a height $h/2$, its will possess :
 - only potential energy
 - only kinetic energy
 - half potential half kinetic energy
 - more kinetic and less potential
- Which of the following quantity can be calculated by multiplying force and velocity ?
 - acceleration
 - power
 - torque
 - work
- The minimum velocity given to an object so that it emerges out from the gravitational field of earth is about _____ :
 - 11.2 km/s
 - 15.3 km/s
 - 5 km/s
 - 9.8 km/s
- When one joule of work is done on a body in one second, power of body is said to be :
 - One watt
 - 0.5 watt
 - zero
 - 100 watt
- The absolute potential energy of an object depends on:
 - The object's mass and height
 - The object's mass and speed
 - The object's shape and size
 - The object's color and temperature
- The escape velocity of a planet depends on which of the following factors?
 - The mass of the planet only
 - The radius of the planet only
 - Both the mass and the radius of the planet
 - The density of the planet

Section (B): Structured Questions

CRQs:

- How does work relate to the transfer of energy?
- How is power related to work and time?
- What is the difference between average power and instantaneous power?

Unit 5: Work, Energy and Power

4. How does gravitational potential energy change with height and mass?
5. What is the law of conservation of energy?
6. How does energy efficiency play a role in various energy transformations?
7. What is the work-energy theorem and how is it expressed mathematically?
8. How is the work done by a variable force calculated?

ERQs:

1. How the work done in gravitational field is independent of path
2. Calculate gravitational potential energy at a certain height due to work against gravity.
3. Describe that the gravitational PE is measured from a reference level and can be positive or negative, to denote the orientation from the reference level.
4. Show that the work done in gravitational field is independent of path
5. Define work by variable force. Calculate the work done from the force-displacement graph.

Numericals:

1. A man pulls a trolley through a distance of 10 m by applying a force of 50 N which makes an angle of 60° with the horizontal. Calculate the work done by the man?
(Ans: 250 J)
2. A 100 kg man runs up a long flight of stairs in 9.8 second. The vertical height of the stair is 10 m. Calculate its power?
(Ans: 1000 Watts)
3. When an object is thrown upwards. It rises to a height 'h'. How high is the object in terms of h, when it has lost one third of its original kinetic energy?
(Ans: h/3)
4. A 70 kg man runs up a hill through a height of 3 m in 2 seconds.
(a) How much work does he do against gravitational field?
(b) What is the average power output?
(Ans: 2060 J, 1030 Watt)
5. A neutron travels a distance of 12 m in a time interval of 3.6×10^{-4} sec. Assuming its speed was constant, Find its kinetic energy? Take the mass of neutron 1.7×10^{-27} kg.
(Ans: 5.78 e V)
6. A stone is thrown vertically upwards and can reach to a height of 10m, find the speed of stone, when it is just 2m above the ground?
(Ans: 12.9 m/s)
7. The potential energy of a body at the top of a building is 200 Joules when it is dropped its kinetic energy just before striking the ground is 160 Joules, find the work done against the air resistance?
(Ans: 40 J)
8. Find the energy equivalent of 1 gram?
(Ans: 9×10^{13} J)
9. A 1Kilowatt motor pump, pumps the water from the ground to a height of 10 m. Find, how much litres of water it can pump in one hour?
(Ans: 3.6×10^4 litre)
10. A rocket of mass 2kg is launched in air, when it attains height of 15m the 400 Joules of its chemical fuel burns. Find the speed of rocket at maximum height?
(Ans: 10 m/s)
11. A motor pumps the water at the rate 500 gram/minute to the height of 120 m. If the motor is 50% efficient then how much input electric power is needed?
(Ans: 20 watt)

Unit

6

Fluid Statics

Teaching Periods 5

Weightage % 4



Darwat Gravity Dam-Sindh District Jamshoro.

Gravity Dam wall must be wider at bottom as it can bear the higher pressure of static Fluids

In this unit student should be able to:

- Describe Pascal's law.
- Describe applications of Pascal's law.
- State Archimedes' principle.
- Derive the equation of upthrust acting on a body in fluid.
- Describe the basic concept of buoyancy.
- State law of flotation.
- Describe surface tension along with suitable examples.

Fluid

Substances which flows are known as fluids. Fluids are divided into gases and liquids as it is given in table:6.1

We breathe in fresh air and drink clean water, blood; a lively fluid circulates in human cardiovascular system. Ships to airplanes, automobiles brake systems to balloons, the usage of fluids and their properties is important to technology and everyday life.

Fluid statics, the study of fluid behavior at rest, has many practical applications in various fields such as:

Civil Engineering, Naval Architecture, Petroleum Engineering, Aerospace Engineering and Biomedical Engineering.

Table 6.1 Fluids are differed as:

Property	Gases	Liquids
Definition	Fluids that conform to the shape of their container	Fluids that maintain a fixed volume but conform to the shape of their container
Shape	No fixed shape	No fixed shape
Volume	Conforms to the shape of their container	Maintains a fixed volume
Compressibility	Highly compressible	Slightly compressible
Density	Low density compared to liquids	Higher density compared to gases
Viscosity	Low viscosity	Higher viscosity compared to gases
Surface Tension	No surface tension	Has surface tension
Free Flow	Freely flows	Flows, but not as freely as gases

6.1 Pascal’s Law:

The French Philosopher and scientist Blaise Pascal published his treatise on the Equilibrium of Liquids in which he discussed the principles of static fluids. For static fluid the net force on any part of the fluid must be zero, otherwise the fluid will flow.

Pascal’s observation - since proven experimentally – provide the foundations for hydraulics, one of the most important developments in modern mechanical technology.

Pascal’s Law states that when a change in pressure is applied at any point to any static fluid, it is transmitted perfectly to all portions of the fluid and to the wall of the container.

For example, as you squeeze your toothpaste tube at one end the same will be transmitted to the opening of tube.

Consider a cylinder of height h and cross-sectional area A with a movable piston of mass m as shown in Fig 6. 1 (a). Adding weight mg at the top of piston increases the pressure at the top, since the extra weight also acts over area of the lid as shown in figure6.1(b). The top of the

piston increases the pressure at the top by $P = Mg/A$ since the additional weight also acts over area A of the lid.

$$P = \frac{F}{A} = \frac{W}{A} \quad \text{--- (6.1)}$$

$$\Delta P_{\text{top}} = \frac{Mg}{A} \quad \text{--- (6.2)}$$

Change in Pressure at upwards =
Change in Pressure downwards

According to Pascal's principle, the Pressure across the water changes by the same amount i.e. Mg/A . Thus pressure at the downwards also increases by Mg/A .

The pressure at downward of the container is equal to the sum of the atmospheric pressure, the pressure due in fluid and pressure supplied by the mass. The change in pressure at the bottom of the container due to mass is

$$\Delta P_{\text{Bottom}} = \frac{Mg}{A} \quad \text{.....(6.3)}$$

Since the pressure changes are same everywhere in the fluid, we no longer need subscripts to designate the change for top or bottom.

$$\Delta P = \Delta P_{\text{top}} = \Delta P_{\text{bottom}} = \Delta P_{\text{everywhere}} \quad \text{.....(6.4)}$$

Pascal's **barrel** is the name of a hydrostatics experiment allegedly performed by Blaise Pascal, which demonstrated the effects of a changing pressure in a fluid.

Thus, **if an external pressure is applied to a confined fluid, the pressure at every point within the fluid increases by that amount of applied pressure.**

Applications of Pascal's Law:

It has various applications in different fields and It is a fundamental principle with widespread effects in fluid mechanics and has been connected in various fields to enable the transmission of forces and pressures in a controlled and efficient manner.

1. Automobile Hydraulic Brake System:

The rear wheel hydraulic brake system of a front-wheel-drive shown in figure 6.2 is

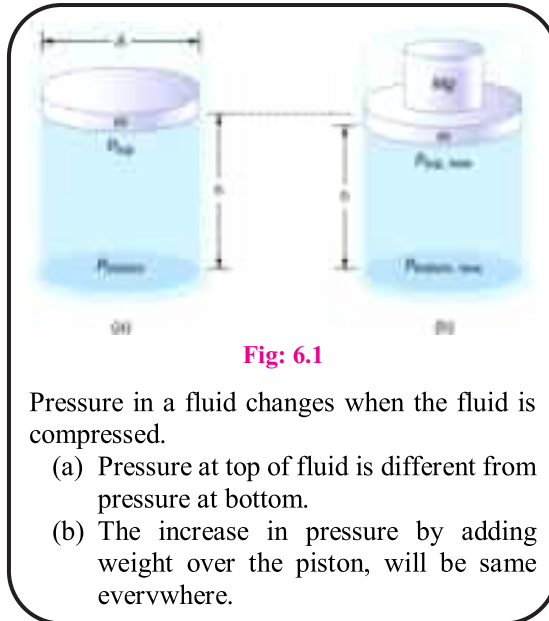

Fig: 6.1

Pressure in a fluid changes when the fluid is compressed.

- (a) Pressure at top of fluid is different from pressure at bottom.
- (b) The increase in pressure by adding weight over the piston, will be same everywhere.

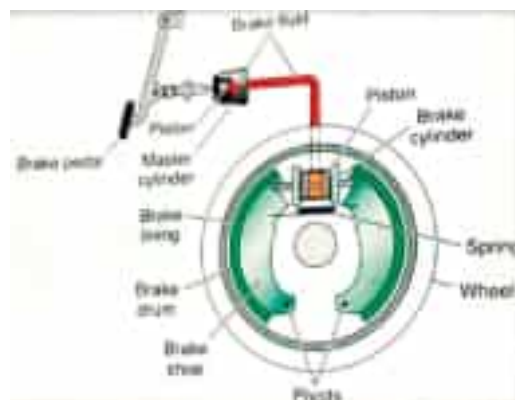

Fig: 6.2

an application of Pascal's principle. When driver pushes the brake pedal, **“The pressure on the piston in master cylinder is transmitted through the brake fluid to the two pistons in the brake cylinder.”**

This transmitted pressure then forces the brake-cylinder pistons to push the brake shoes against the brake drum and stop the automobile. Now by releasing the brake pedal releases the pressure on the pistons in the brake cylinder. The spring pulls the brake shoes away from the brake drum, which allows the wheel to turn freely again.

2. Hydraulic Lift or Hydraulic Jack:

Hydraulic lift is able to raise up large weight up to relatively short distance.

The hydraulic lift, or jack is applications of hydraulics being used as a simple machine to multiply force.

It contains an incompressible fluid in a U-shaped tube which is narrower at start and becomes wider area at end which is fixed with a movable piston on each side. If a small force F_1 is applied to the small piston of the hydraulic lift as shown in figure 6.3, the pressure is transmitted with in all directions. The pressure on the large piston is the same as the pressure on the small piston; **however, the force F_2 on the large piston is greater because of its large surface area which used to uplift the car.**

From Pascal's principle, the force needed to lift the automobile is less than the weight of the automobile.

$$\frac{F_1}{A_1} = \frac{F_2}{A_2} \dots \dots (6.5)$$

OR

$$\frac{F_2}{F_1} = \frac{A_2}{A_1}$$

Mechanical advantage (M.A) = $\frac{F_2}{F_1}$, which is equal to the ratios of areas.

For example, if the area of output piston is 20 times that of the input cylinder, the force multiplied by a factor of 20. Thus, a force of 200 lbs. could lift a 4000 lbs. of weighing automobile

Activity:

Hold a spoon in a stream of water tap and feel the effect of the differences in pressure



Fig: 6.3

DO YOU KNOW?

When the hand pump handle is pushed down and the piston is raised, air in the pipe is 'thinned' as it expands to fill a larger volume.

Atmospheric pressure on the well surface pushes water up into the pipe, causing water to overflow at the sprout.



Worked Example 6.1

A hydraulic system consists of two connected cylinders, Cylinder A and Cylinder B. Cylinder A has a piston with a radius of 5 cm and Cylinder B has a piston with a radius of 10 cm. A force of 200 N is applied to Cylinder A. Calculate the force exerted by Cylinder B.

Solution:

Data:

Radius of Cylinder A = 5 cm = 0.05 m

Radius of Cylinder B = 10 cm = 0.1 m

Force applied to Cylinder A $\vec{F}_A = 200\text{N}$

Step 1: According to Pascal's law, the pressure exerted on the fluid in Cylinder A is transmitted equally to the fluid in Cylinder B. Therefore, the pressure in both cylinders will be the same.

Step 2: The formula for pressure is:

Pressure (P) = Force (F) / Area (A)

The area of a cylinder can be calculated using the formula:

Area (A) = πr^2

Let's calculate the pressure in Cylinder A:

Area of Cylinder A = πA^2

= $(3.14) (0.05)^2 = 0.00785 \text{ m}^2$

Pressure in Cylinder A $P_A = \vec{F}_A / A$

= $200 \text{ N} / 0.00785 \text{ m}^2$

≈ 25477 Pa

Step 3: Since the pressure is the same in both cylinders, we can calculate the force exerted by Cylinder B using the pressure and the area of Cylinder B:

Area of Cylinder B = πB^2

Area of Cylinder B = $3.14 (0.1\text{m})^2$

= 0.0314 m^2

Step 4: Force exerted by Cylinder B (\vec{F}_B) = Pressure (P_A) × Area (B)

= $25477 \text{ Pa} \times 0.0314 \text{ m}^2$

≈ **800 N**

Therefore, the force exerted by Cylinder B is approximately **800 N**, in accordance with Pascal's law.

**Self-Assessment Questions:**

1. How does Pascal's Law relate to the transmission of pressure in a confined fluid?
2. How does the principle of hydraulic systems rely on Pascal's Law?

6.2 Archimedes' Principle:

Archimedes', a Greek physicist of 3rd century, his best-known achievement was his "Eureka" moment when he discovered the principle of flotation. Through which he understood that why objects appear to weigh less when immersed in a denser fluid?

6.2.1 Archimedes' principle:

It states that when an object is immersed into a liquid, it experiences upward thrust which is equal to the weight of the liquid displaced by that object.

The magnitude of the upward force depends upon:

- Volume of the body- more fluid that is displaced, the greater the upthrust.
- Density of fluid- the greater the density, greater is upthrust.

It should be clear from the above that a floating body will displace its own weight of fluid such that there is no vertical resultant force on the body.

Therefore, if a sphere of material density ρ with radius r is fully immersed into a liquid of density σ ; shown in figure 6.4, the apparent weight of sphere is given by

$$\text{Apparent Weight} = \text{Actual Weight} - \text{upthrust} \dots\dots(6.6)$$

The fluid may either be a liquid or air which have low density (about 1 Kg m^{-3}), the upthrust in air is usually small, but sufficient to support a helium filled balloon uplift.

DO YOU KNOW?

Physics in History

Archimedes' (287 – 212 BC) had been given the task of determining whether a crown made for King Hiero II of Syracuse was of pure gold when he noted the rise in water level while immersing his body in the public baths of Syracuse. Legend reports that he excitedly rushed through streets shouting "Eureka! Eureka!" (I have found it! I have found it!).

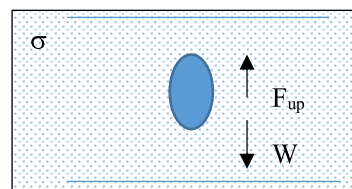

Fig: 6.4

Worked Example 6.2

When a crown of mass 14.7 kg is submerged in water, an accurate scale reads only 13.4 kg . Is the crown made of gold?

Approach:

If the crown is gold, its density and specific gravity must be very high.

Solution:

Step 1: Formula: $W_a = F_r = W - F_B$

$$W - W_a = F_B$$

Step 2: Let V be the volume of completely submerged object and ρ_o the object's density (So $\rho_o V$ is its mass), and let ρ_f is fluid density (water). Then $\rho_f V$ is the weight of fluid displaced, then

$$W = mg = \rho_o Vg$$

$$W - W_a = F_B = \rho_f Vg$$

By dividing them

$$\frac{W}{W - W_a} = \frac{\rho_o Vg}{\rho_f Vg} = \frac{\rho_o}{\rho_f}$$

Step 3: Density of fluid i.e. water is $1 \times 10^3 \text{ kg/m}^3$

$$\frac{\rho_o}{\rho_f} = \frac{W}{W - W_a} = \frac{(14.7 \text{ kg})g}{(14.7 \text{ kg} - 13.4 \text{ kg})g} = 11.3$$

This shows that crown is not made of gold rather made of lead.

Upthrust:

It is the force exerted upwards on an object submerged in a fluid, equal in magnitude to the weight of the fluid displaced by the object. It is a result of Archimedes' principle, which states that the upward buoyant force on an object is equal to the weight of the fluid it displaces. This force helps to support the object and prevent it from sinking. As much as object dips deeper, pressure increases with depth. So, the object has difference in pressure at top and bottom. This difference of pressure produces an upward force which is called upthrust. It is also known as buoyancy or buoyant force.

Upthrust is significantly larger in liquids than in gasses, because liquids are much denser than gasses.

Consider a cylinder of height 'h' and area of cross-section 'A' is immersed in a vessel containing a liquid of density ρ . The upthrust as shown in figure 6.5 is acting on the cylinder from bottom to top is given as

$$\Delta P = \frac{F}{A}$$

$$F_{\text{thrust}} = \Delta P \times A$$

$$F_{\text{thrust}} = -\rho g \Delta h \times A$$

$$F_{\text{thrust}} = -\rho g V \dots\dots(6.7)$$

The equation of upthrust

where

F_{thrust} = Upthrust or Buoyant force

ρ = density of fluid

g = acceleration due to gravity (Upwards)

V = Volume of fluid

If the object has same density as of liquid, then it will stay, neither sinking nor floating just as the liquid nearby banks stays still. But if the object is denser than liquid, then same volume will weigh more and it will sink, because the upthrust will not be enough to support it. If the object has less density, the upthrust will make it float up to surface.

Explore:

Look in the table 6.1 and decide which substances will sink in water. What will afloat on mercury? Will ice float on petrol?

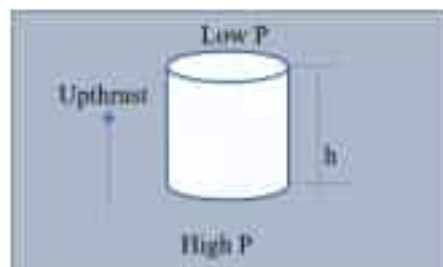

Fig: 6.5

Table 6.1

Substance			Density	
Solid	Liquid	Gas	Kg/m ³	g/m ³
Gold			19000	19
	Mercury		13600	13.6
Iron			8800	8.8
	Water		1000	1
Ice			920	0.92
	Petrol		800	0.8
		Air	1.3	0.013
Lead			11340	11.34

Self-Assessment Questions:

1. How is the weight of the displaced fluid related to the upthrust acting on an immersed object?
2. How do submarines and hot air balloons take advantage of the principles of Archimedes' theory in their design and operation?

6.3 Buoyancy and law of flotation:

Buoyancy and flotation are fundamental principles governing the behavior of objects in fluids, particularly liquids like water. Buoyancy is the upward force exerted by a fluid on an immersed object, opposing gravity, and enabling objects to float or sink. Flotation is closely related and refers specifically to an object's ability to stay afloat on the liquid surface. Understanding these principles is crucial in various fields, such as shipbuilding, engineering, swimming, and boating, allowing us to comprehend why objects float or sink and design stable structures and vessels in fluid environments.

6.3.1 Buoyancy:

Buoyancy is the upward force exerted by a fluid on an immersed object. It is a result of the pressure difference between the top and bottom surfaces of the object due to the weight of the displaced fluid.

The magnitude of the buoyant force is equal to the weight of the fluid displaced by the object. This can be calculated using Archimedes' principle, which states that the buoyant force is equal to the weight of the fluid displaced by the object.

The formula to calculate the buoyant force is:

$$\text{Buoyant Force} = \text{Density of Fluid} \times \text{Volume of Displaced Fluid} \times \text{Acceleration due to Gravity}$$

where:

Density of Fluid is the density of the fluid in which the object is submerged.

Volume of Displaced Fluid is the volume of the fluid displaced by the object.

Acceleration due to Gravity is the acceleration experienced by objects due to the Earth's gravitational field (approximately 9.8 m/s^2).

The buoyant force acts in the opposite direction to gravity, resulting in an apparent reduction in the weight of the object when it is submerged in a fluid.

For an object fully submerged in a fluid, the volume of displaced fluid is equal to the volume of the object itself. If the object is partially submerged, only the submerged portion contributes to the volume of displaced fluid.

The buoyant force is the reason why objects appear to be lighter when submerged in water or other fluids. It is also the principle behind the floating of ships and other vessels, as the buoyant force is greater than the weight of the ship, allowing it to stay afloat.

In liquids:

- If the weight of the submerged object is greater than buoyant force, the object sinks.
- If the weight of object is equal to the buoyant force acting upwards on the submerged object, it remains at any level in fluid, like a fish.
- If the buoyant force is greater than the weight of object which is completely submerged, it rises to the surface and floats.

For example, a ship that is launched into sea, sinks into the ocean until the weight of the water it displaces is just equal to its own weight. As the ship is loaded, it sinks deeper, displacing more

water, and so the magnitude of the buoyant force continuously matches the weight of the ship and its cargo.

In gases:

We live at the bottom of ocean of air and look upward at balloons and other lighter than air objects are drifting above us. Air pressure acting upward against an object immersed in air is greater than the pressure above pushing down. The buoyancy is equal to the weight of fluid displaced. So, Archimedes' principle also implies to air which is stated as:

'An object surrounded by air is buoyed up by a force equal to the weight of the air displaced.'

A cubic meter of air at normal atmospheric pressure and room temperature has a mass of about 1.2 Kg, so its weight becomes around 12 N.

- If the mass of the 1 m^3 object is greater than 1.2 Kg, it falls to the ground, when released.
- If an object of this size has mass of less than 1.2 Kg, buoyant force is greater than weight and it rises in air.

Because gas (Hydrogen or Helium) filled in balloons that rises in air are less dense than air. Air becomes less dense at high altitude; a lesser weight of air is displaced per given volume as the balloon rises. When the weight of displaced air equals the total weight of the balloon, upward motion of balloon ceases. It can be stated as when the buoyant force on the balloon equals its weight, the balloon ceases to rise.

6.3.2 Law of Flotation:

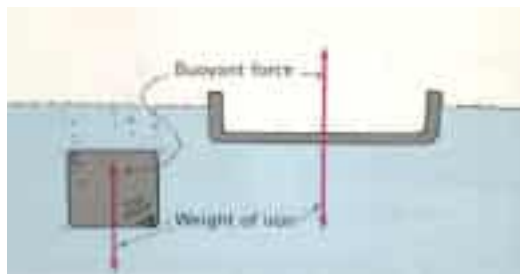

Fig: 6.6

why a ship made of iron floats? Whereas Iron block sink, suppose an iron block is of one ton, so when it is submerged into water, it displaces only $1/8$ ton of water, which is certainly not enough to prevent it from sinking. Contrary, if we reshape same one-ton iron into a bowl shape. When it submerges it into water, it settles into water by displacing a greater volume of water as compared to earlier shape(Block).

DO YOU KNOW?

Floating Mountains

Mountains are bigger than they appear to be. The concept of mountain floating is Isostasy-Archimedes' principle for rocks.

Isostasy is the rising or settling of a portion of the Earth's lithosphere that occurs when weight is removed or added in order to maintain equilibrium between buoyancy forces that push the lithosphere upward and gravity forces that pull the lithosphere downwards

Isostasy



DO YOU KNOW?

Iron is nearly eight times denser than water

The deeper it immersed, the more water it displaces, and the greater buoyant force acting on it. When the iron boat displaces a weight of water equal to its own weight, it floats. Then principle of flotation is stated as:

‘A floating object displaces a weight of fluid equal to its own weight.’

Every ship or submarine must be designed to displace weight of fluid equal to its own weight. Thus a 10K tons ship must be built wide enough to displace 10K tons of water before it immersed too deep in the water.

In Gases:

A dirigible airship or huge balloon that weighs 100 tons displaces at least 100 tons of air. If it displaces more, it rises. If it displaces less, it descends. If it displaces exactly as its weight, it hovers at constant altitude.

Because the buoyant force upon a body equals the weight of the fluid it displaces, denser fluids exert more buoyant force upon a body than less dense fluids of the same volume. A ship therefore floats higher in salt water and little bit deep in fresh water. In the same way, a solid chunk of iron floats in mercury even though it sinks in water.

Activity:

Try to float an egg in water, it needs dissolve salt in the water until the egg floats. How does the density of an egg compare to that of tap water? To salt water?

DO YOU KNOW?

Scuba diving is an underwater activity where a person breathes from a tank of air while they swim below the surface of the water. The word "scuba" stands for Self-Contained Underwater Breathing Apparatus, which refers to the equipment used to facilitate underwater breathing. This allows a diver to stay underwater for extended periods of time, allowing them to explore the underwater environment, observe marine life, and participate in various underwater activities.

Worked Example 6.3

What volume V of a helium is needed if a balloon is to lift a load of 185 kg?

Step 1: $M = 185 \text{ kg}$

The buoyant force on the helium balloon F_b , which is equal to the weight of displaced air, must be at least equal to the weight of the helium plus the weight of balloon and load, the density of helium is 0.179 kg/m^3 density of air is 1.29 kg/m^3 .

Step 2: $F_b = (m_{\text{hel}} + 185) g$

This equation is written in terms density by using Archimedes' principle

$\rho_{\text{air}} V g = (\rho_{\text{hel}} V + 185) g$

Step 3: Solving for V , we get

$$V = \frac{185}{\rho_{\text{air}} - \rho_{\text{hel}}}$$

$$V = \frac{185}{1.29 - 0.179}$$

$$V = 166.5 \text{ m}^3$$



Worked Example 6.4

A solid, square pine wood raft measures 4.5 m on a side and is 0.35 m thick. (a) Determine whether the raft floats in water and (b) if so how much of the raft is beneath the surface the distance h ?

Step 1:

Side = 4.5 m

Thickness = 0.35 m

Step 2:

To determine whether the raft floats, we will compare the weight of the raft to the maximum possible buoyant force and see whether there could be enough buoyant force to balance the weight. If so, then the value of the distance h can be obtained by utilizing the fact that the floating raft is in equilibrium, with the magnitude of the buoyant force equalizing the raft's weight.

Step 3:**(a)**

$W_{\text{raft}} = m_{\text{pine}} g$ where m_{pine} can be calculated by Density \times Volume.

$$W_{\text{raft}} = 550 \times 7.1 \times 9.8$$

$$W_{\text{raft}} = 38269 \text{ N}$$

$$F_B = (\rho V g)_{\text{water}} = 1000 \times 7.1 \times 9.8 = 69580 \text{ N}$$

Since the maximum possible buoyant force exceeds the 38269 N weight of the raft, the raft will float only partially submerged at a distance h beneath the water.

(b)

The buoyant force balances the raft's weight, so $F_B = 38269 \text{ N}$. Using the density of water and volume of water $4 \text{ m} \times 4 \text{ m} \times h$.

$$38269 \text{ N} = W_{\text{water}} = \rho_{\text{water}} \times (4.5 \text{ m} \times 4.5 \text{ m} \times h) \times 9.8$$

Solving for h , we get

$$h = 0.19 \text{ m}$$

Self-Assessment Questions:

1. Why does a steel ship, which is denser than water, float on the surface of the sea according to the principles of buoyancy and the Law of Flotation?
2. Describe the "Law of Flotation" and its application to objects floating in a fluid.

6.4 Surface Tension:

Why liquid drops are spherical, why water rises up in a capillary tube, why certain insects are called pond – skaters who can walk over the surface of water pond. And why the bristles of a paint brush cling together when is taken out of water. All these phenomena can be explained by understanding concept of Surface tension.

The existence and behavior of molecules can be verified by the properties of liquids. Suppose an imaginary free surface of liquid as shown in figure (6.7). The molecules lying on the surface are behaving as tug of war i.e. one side molecules

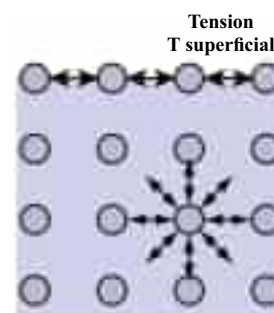

Fig: 6.7 Surface tension

pull to their side while other side molecules to their side in order to decrease the surface area. Hence, surface tension is defined as

“The force per unit length acting on either side of the imaginary line drawn on the liquid surface at rest. The direction of force is tangential to the surface and perpendicular to the line”.

Surface Tension = $\frac{F}{L}$ Its SI unit is N/m or N·m⁻¹.

It is the ability of the surface of a liquid to act like a thin flexible film. As surface of the water to support a needle, The water’s surface acts like a thin flexible film

Consider a U-shaped apparatus which encloses a thin film of liquid (Liquid soap film). As shown in figure: 6.8 (a,b) Because of surface tension, a force F is required to pull the movable wire and this increase the surface area of the liquid. The liquid contained by the wire apparatus is thin film having both top and bottom surface. Hence the total length of the surface being increased is 2L and the surface tension is

$$T = \frac{F}{2L} \dots\dots(6.8)$$

A delicate apparatus of this type can be used to measure the surface tension of various liquids. The surface tension of water is 0.072 N/m at 20°C. Table shows the standard values of certain liquids

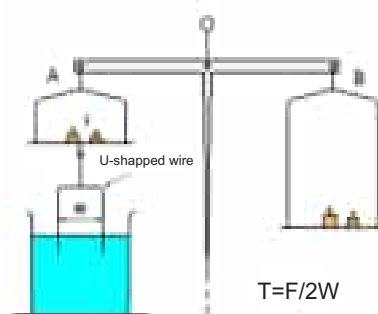

Fig: 6.8 (a)

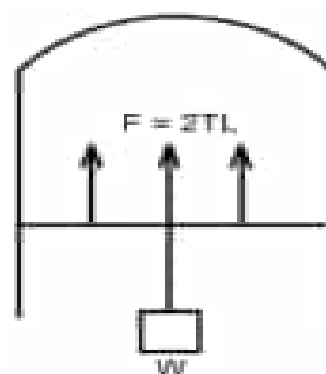

Fig: 6.8 (b)

Table 6.2: Surface Tension of Substances

Substance	Surface Tension N/m
Mercury (20°C)	0.44
Blood Whole (37 °C)	0.058
Blood Plasma (37 °C)	0.073
Alcohol, Ethyl (20°C)	0.023
Water (0 ° C)	0.076
Water (20°C)	0.072
Water (100 °C)	0.059
Benzene (20°C)	0.029
Soap Solution (20°C)	0.025
Oxygen (- 193 °C)	0.016

DO YOU KNOW?

The surface tension can be reduced by adding soap or detergent powders called surfactants’ to laundry water so that the water can more easily be penetrated into the fibers of the clothes being washed.

6.4.1 Examples:

1. When a pin is placed gently over the surface of water, it floats as shown in figure 6.9(a). There is a depression of the surface which behaves like a stretched membrane. As needle is pressed with a finger, the layer of surface tension breaks and the needle sink in the water.



Fig: 6.9 (a)

2. Some insects (with long legs) can walk over the water surface. Surface tension of water supports the weight of insect. Actually insect sinks slightly into the fluid so its weight becomes effective weight of that insect, its true weight is less than the buoyant force.
3. A drop of Olive oil is dropped through a pipette, gently inside a mixture of alcohol and water, which forms a perfectly spherical shape. The density of the mixture is same as of olive oil. Due to surface tension, the tendency of a liquid surface is to keep its area minimum. For a given volume, the surface area of a sphere is minimum. Due to this reason, the raindrop is in spherical shape.
4. When a mercury is dropped over glass surface, the globules are spherical in shape.
5. Capillarity
A glass tube of small bore is dipped into water; it rises up the tube a few centimeters. As tube becomes narrower, there is more rise up. Adhesion force between water and glass exceeds cohesion force between water molecules, the meniscus causes up and surface tension.

DO YOU KNOW?

A drop is shown in three different shapes, as

1. Surface tension causes a drop of mercury to be more spherical.
2. Surface tension causes a liquid drop to hold together.
3. The shape of falling rain drop is due to the friction of air.

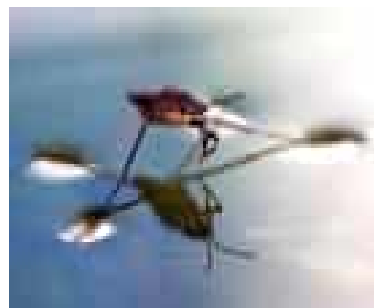

Fig: 6.9 (b)

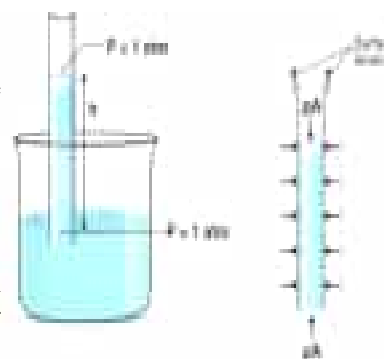

Fig: 6.10

This effect is called capillarity or capillary action. The height of column can be calculated by:

$$h = \frac{2T}{\rho r g}$$

T= Surface Tension

r= radius of tube

g= Acceleration due to gravity

ρ =Density of liquid

Worked Example 6.5

The base of an insect's leg is approximately spherical in shape, with a radius of about 2.1×10^{-5} m. The 3.2×10^{-6} kg mass of insect is supported by equally by its six legs. Estimate the angle for an insect on the surface of water. Assume water temperature is 20°C .

Step 1:

$$r = 2.1 \times 10^{-5} \text{ m}$$

$$m = 3.2 \times 10^{-6} \text{ kg}$$

$$\theta = ?$$

Since the insect is in equilibrium, the upward surface tension force is equal to the effective pull of gravity down ward on each leg.

Step 2:

For each leg, we assume the surface tension force acts all around the circle of radius r , at an angle θ . Only the vertical component, $\gamma \cos \theta$, acts to balance the weight mg . So, we set the length L equal to circumference of the circle $L = 2\pi r$. Then the net upward force is due to surface tension is $F_y = (\gamma \cos \theta) L = (\gamma \cos \theta) 2\pi r$. We set this surface tension force γ equal to one-sixth the weight of the insect since it has six legs:

Step 3:

$$2\pi r \gamma \cos \theta = 1/6 mg$$

$$2\pi (2.1 \times 10^{-5}) (0.072) \cos \theta = 1/6 (3.2 \times 10^{-6}) (9.8)$$

$$\theta = 56^\circ$$

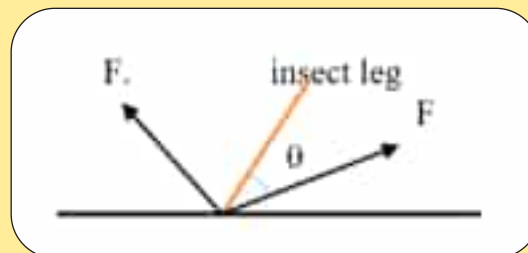

Worked Example 6.6

Water flows through a fire hose of diameter 6.5 cm at a speed of 5.99 m/s. Find the flow rate of the fire hose in L/min.

Step 1:

$$v = 5.99 \text{ m/s}$$

$$r = 3.25 \text{ cm} = 0.0325 \text{ m}$$

$$A = \pi r^2 = 3.14 (0.0325)^2$$

flow rate = ?

Step 2:

$$\text{Flow Rate} = Av$$

$$\text{Flow Rate} = (5.99) \times \pi (0.0325)^2$$

$$\text{Flow Rate} = 0.01988 \text{ m}^3/\text{s} \times (1000 \text{ L} / \text{m}^3) (60 \text{ s} / 1 \text{ min})$$

$$\text{Flow Rate} = 1192 \text{ L/min}$$

Self-Assessment Questions:

1. Explain the difference between cohesive forces and adhesive forces in the context of surface tension.
2. How does surface tension impact the behavior of liquid droplets, bubbles, and capillary action?



SUMMARY

- Substances which flows are known as fluids.
- The change in pressure is applied at any point to an enclosed fluid, it is transmitted perfectly to all portions of the fluid and to the wall of the container.
- An object is immersed in a liquid, it experiences upward thrust which is equal to the weight of the liquid displaced by that object.
- An object is submerged partly or completely into a fluid, an upward force is exerted by the fluid. As much as object dips deeper, pressure increases with depth. So, the object has difference in pressure at top and bottom. This difference of pressure produces an upward force which is called upthrust. It is also known as buoyancy or buoyant force.
- Bouncy is the ability of an object to float in fluid.
- A floating object displaces a weight of fluid equal to its own weight.
- The force per unit length acting on either side of the imaginary line drawn on the liquid surface at rest. The direction of force is tangential to the surface and perpendicular to the line.

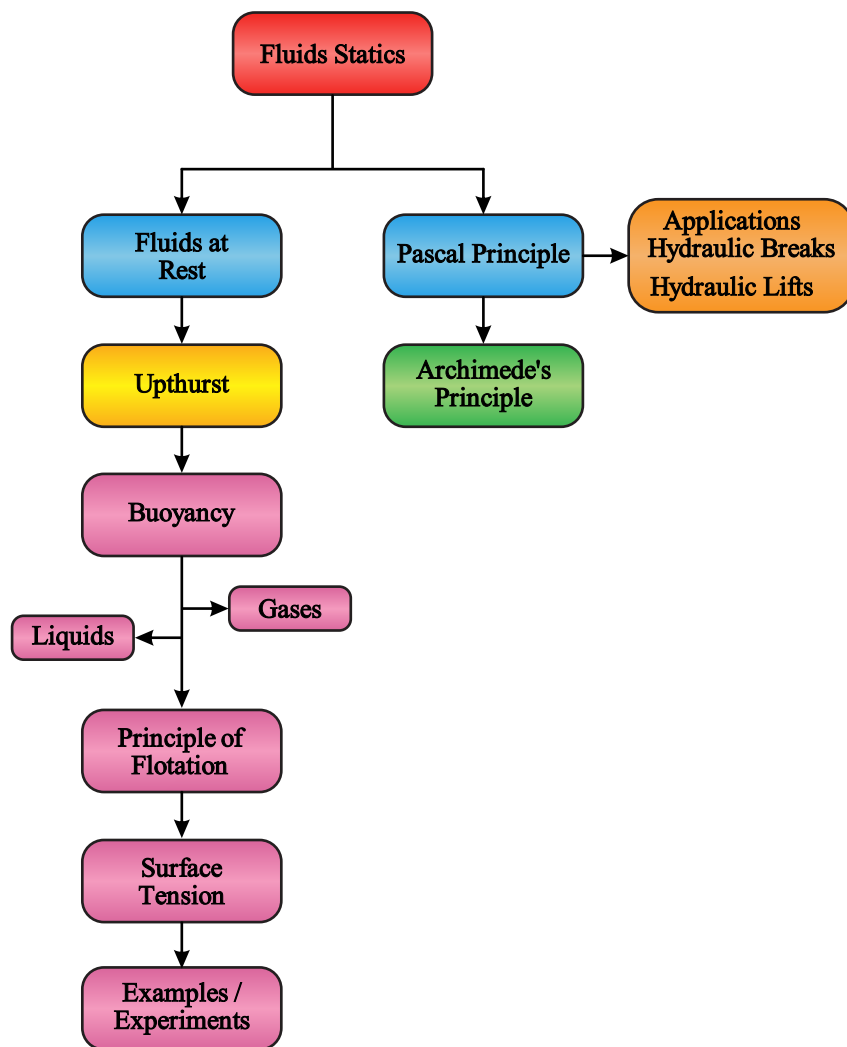



EXERCISE

Section (A): Multiple Choice Questions (MCQs)

- A completely submerged object always displaces its own _____
 - weight of fluid
 - volume of a fluid
 - density of a fluid
 - Area of fluid
- The pressure exerted on the ground by a man is greatest when:
 - he stands with both feet flat on the ground
 - he stands flat on one foot
 - he stands on the toes of one foot
 - he lies down on the ground
- In a stationary homogeneous liquid:
 - pressure is the same at all points
 - pressure depends on the direction
 - pressure is independent of any atmospheric pressure on the upper surface of the liquid
 - pressure is the same at all points at the same level
- One piston in a hydraulic lift has an area that is twice the area of the other. When the pressure at the smaller piston is increased by Δp the pressure at the larger piston:
 - increases by $2\Delta p$
 - increases by $\Delta p/2$
 - increases by Δp
 - increases by $4\Delta p$
- In a vacuum, an object has
 - No buoyant force
 - no mass
 - no weight
 - none of these
- The pressure at the bottom of a pond does NOT depend on
 - Water density
 - the depth of the pond
 - the surface area of the pond
 - None of these
- A rock suspended by a weighing scale weighs 5N out of water and 3 N when submerged in water. What is the buoyant force on the rock?
 - 3 N
 - 5 N
 - 8N
 - 15 N
- “An object completely submerged in a fluid displaces its own volume of fluid”. This is:
 - Pascal’s paradox
 - Archimedes’ principle
 - Pascal’s principle
 - true, but none of the above
- Salt water has greater density than freshwater. A boat floats in both freshwater and saltwater. The buoyant force on the boat in salt water is ----- that in freshwater.
 - equal to
 - smaller than
 - larger than
 - same as
- You fill a tall glass with ice and then add water to the level of the glass’s rim, so some fraction of the ice floats above rim. When the ice melts, what’s happens to the water level?
 - the water overflows the rim
 - the water level drops below the rim
 - the water level stays at the rim
 - it depends on the difference in density between water and ice

SRQ's

1. State Pascal's principle. Describe its two applications.
2. (a) Why must a liquid and not a gas be used as the 'fluid' in a hydraulic machine?
(b) On what other important property of a liquid do hydraulic machines depend?
3. Why don't ships made of iron sink?
4. Why do you float higher in salt water than in fresh water?
5. What is the difference between being immersed and being submerged in water?
6. Define surface tension and give its any two applications.
7. A swimmer dives off a raft in a pool. Does the raft rise or sink in the water? What happens to the water level in the pool? Give reasons for your answer.
8. Distinguish between flotation and upthrust.

ERQ's

1. Discuss buoyancy in liquids and gases.
2. Describe law of flotation in liquids and gases.
3. Discuss surface tension with at least three experiments.
4. Explain Archimedes principle and find gold purity by using density.

Numericals

1. In a hydraulic press a force of 20 N is applied to a piston of area 0.20 m^2 . The area of the other piston is 2.0 m^2 . What is (a) the pressure transmitted through the fluid; (b) the force on the piston?
(200 N, 100 Pa)
2. The pressure in a water pipe in the ground floor of a building is $4 \times 10^5 \text{ Pa}$ but three floors up it is only $2 \times 10^5 \text{ Pa}$. What is the height between the ground floor and the third floor? The water in the pipe may be assumed to be stationary; density of water $= 1 \times 10^3 \text{ Kg/m}^3$
(20 m)
3. The small piston of hydraulic press has an area of 10.0 cm^2 . If the applied force is 50.0 N, what must the area of the large piston to exert a pressing force of 4800N? **(960 cm^2)**
4. Mechanical advantage of a hydraulic jack is 420. Find the weight of the heaviest automobile that can be lifted by an applied force of 55 N.
(23000 N)
5. A flat -bottom river barge is 30 ft wide, 85 ft long and 15 ft. deep, (a) how many m^3 of water will displace while the top stays 1 m above the water.? (b) What load in tons will the barge contain under these conditions if the empty barge weighs 160 tons in dry dock?
($3.1 \times 10^4 \text{ ft}^3$, 800 tons)
6. A canal lock gate is 20 m wide and 10 m deep. Calculate the thrust acting on it assuming that the water in the canal is in level with the top of the gate. Density of water is 1000 kg/m^3
($9.8 \times 10^4 \text{ N}$)

7. A tank 4 m long, 3 m wide and 2 m deep is filled to the brim with paraffin (density 800 kg/m^3). Calculate the pressure on the base? What is the thrust on the base?
(16000 Pa, 19200 N)
8. A rectangular boat is 4.0 m wide, 8.0 m long, and 3.0 m deep. (a) How much water will it displace if the top stays 1.0 m above the water? (b) What load will the boat contain under these conditions if the empty boat weighs $8.60 \times 10^4 \text{ N}$ in dry dock?
(Weight density of water = 9800 N/m^3) **(64.0 m³, $5.41 \times 10^5 \text{ N}$)**
9. A hot air balloon has a volume of 2200 m^3 . The density of air at temperature of 20°C is 1.205 kg/m^3 . The density of the hot air inside the balloon at a temperature of 100°C is 0.946 kg/m^3 . How much weight can the hot air can lift?
(5590 N)
10. A spherical balloon has a radius of 7.15 m and is filled with helium. How large a cargo can it lift, assuming that the skin and structure of the balloon have a mass of 930 kg? Neglect the buoyant force on the cargo volume itself.
(920 kg, $9 \times 10^3 \text{ N}$)

Unit

7

Fluid Dynamics

Teaching Periods 9

Weightage % 6



Wind energy form at Gharo: Energy driven through air.

In this unit student should be able to:

- Describe that real fluids are viscous fluids.
- Describe that viscous forces in a fluid cause a retarding force on an object moving through it.
- Explain how does the magnitude of the viscous force on an object moving in fluid depend on the size and velocity of the object.
- Apply Stokes' law to derive an expression for the terminal velocity of spherical body falling through a viscous fluid.
- Use the equation of terminal velocity to solve problems.
- Define the terms: steady (streamline or laminar) flow, incompressible flow and non-viscous flow as applied to the motion of an ideal fluid.
- Explain that at a sufficiently high velocity, the flow of viscous fluid undergoes a transition from laminar to turbulence conditions.
- Describe that the majority of practical examples of a fluid flow and resistance to motion in fluids involve turbulent rather than laminar conditions.
- Identify that the equation of continuity is a form of the principle of conservation of mass.
- Solve problems by using the equation of continuity.
- Describe that the pressure difference can arise from different rates of flow of a fluid (Bernoulli's Effect).
- Interpret and apply Bernoulli Effect in the: filter pump, Venturi meter, atomizers, flow of air over an aero foil and in blood physics.

Fluid Dynamics:

In our daily life, we observe the motion of fluids i.e. gases and liquids through pipes, ducts and passage ways. Examples in our daily life are – water streams from a fire hose, blood courses through our veins. Why does rising smoke curl and twist? How does a nozzle increase the speed of water emerging from nose? How does the body regulate blood flow? The physics of fluids in motion -fluid dynamics-allows us to answer these and many other queries.

Aircraft move through the air, when a fluid is in motion or an object move through a fluid, the pressure within fluid varies with velocity. The forces generated by this pressure difference were explained in 1852 by the German physicist Gustav Magnus. He resolved the problems of, why projectiles spinning about an axis other than their direction of motion will curve off course. Such spinning is played technically by bowler through bowling as swing of ball. Air dynamics is used in throwing and kicking the ball in cricket and football respectively. These phenomenon plays vital role science and technology to make our games exciting.

7.1 Fluid Friction:

7.1.1 Real Fluids are viscous fluids:

Viscous fluids are fluids that resist deformation and flow. They have a high resistance to shear or flow and exhibit internal friction between adjacent layers of the fluid. This internal friction is responsible for the viscosity of the fluid.

Viscous fluids can be found in many aspects of our daily lives. Here are a few examples:

Honey or Syrup: Honey and syrups are examples of highly viscous fluids. When you pour honey or syrup from a container, it flows slowly and tends to stick to the spoon or container. The resistance to flow and the slow pouring rate are due to the high viscosity of these fluids.

Motor Oil: Motor oil used in engines also exhibits viscosity. It is designed to have a certain viscosity to provide lubrication and minimize friction between engine parts. High-viscosity motor oil is used in engines with larger clearances, while low-viscosity oil is used in engines with smaller clearances.

Paint or Varnish: Paints and varnishes also exhibit viscosity. When you apply paint to a surface, it adheres and spreads according to its viscosity. High-viscosity paints are thicker and tend to form thicker layers, while low-viscosity paints flow more easily and may result in thinner coatings.

These examples highlight the behavior of viscous fluids in different situations. Viscosity plays a crucial role in various aspects of our daily lives, from cooking to transportation to manufacturing processes. Understanding and controlling the viscosity of fluids is essential in numerous industries and scientific fields.

7.1.2 Viscous force in a fluid:

Viscous force is an opposition between layers of a fluid. Viscous forces in a fluid are proportional to the rate of change of velocity of fluid's layers. The viscosity of a fluid serves as the proportionality constant.

Suppose a viscous fluid between two plates in which one plate is stationary and other is moveable as shown in (figure 7.1).

The fluid is directly in contact with each plate is held to surface by the adhesive force between the molecules of the liquid and those of the plates. Thus, the upper surface of the fluid moves with the same speed v as the upper plate, whereas the fluid in contact with the stationary plate remains stationary.

The stationary layer of fluid retards the flow of the layer just above it, which in turn retards the flow of next layer, and so on. Thus, the velocity varies continuously from 0 to v through the fluid. The increase in velocity divided by the distance over which change is made – equal to $\frac{v}{l}$ is called the **velocity gradient** which is defined as ‘*the rate of change of velocity with distance normal to the direction of flow of the layers of the fluid with respect to object passing through the fluid*’.

Viscosity is a fluid’s resistance to flow. Fluids resist the relative motion of the immersed objects through them as well as to the motion of layers with differing velocities within them.

For a given fluid, it is required force F which is proportional to the area of fluid in contact with each plate ‘ A ’, and to the speed, ‘ v ’, and is inversely proportional to the separation ‘ l ’, between the plates as shown in figure 7.1.

$$F \propto v \frac{A}{l}$$

For more viscous fluid, the greater force is the required.

Hence, the proportionality constant for this equation is defined

as the coefficient of viscosity η which is intrinsic property of the fluid.

$$F = \eta A \frac{v}{l} \text{----- (7.1)}$$

$$\eta = \frac{F/A}{v/l}$$

The SI unit for η is $\text{N}\cdot\text{s}/\text{m}^2 = \text{Pa}\cdot\text{s}$ (Pascal. Second). In CGS system, its unit is called dyne. s/cm^2 , which is called a Poise (P). The temperature has a strong effect; the viscosity of liquids such as motor oil decreases rapidly as temperature increases, while for gases it increases.

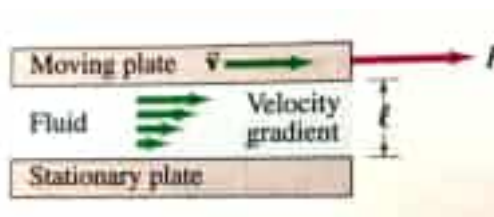

Fig: 7.1
viscous fluid between two plates

Table 7.1: Coefficients of Viscosity

Fluid (Temperature in $^{\circ}\text{C}$)	Coefficient of viscosity, η (Pa. s)
Water (0$^{\circ}$)	1.8×10^{-3}
(20$^{\circ}$)	1.0×10^{-3}
(100$^{\circ}$)	0.3×10^{-3}
Whole Blood (37$^{\circ}$)	$\approx 4.0 \times 10^{-3}$
Blood Plasma (37$^{\circ}$)	$\approx 1.5 \times 10^{-3}$
Engine Oil (30$^{\circ}$)	2.0×10^{-1}
Glycerin (20$^{\circ}$)	1.5×10^{-1}
Air (20$^{\circ}$)	1.8×10^{-5}
Hydrogen (0$^{\circ}$)	9.0×10^{-6}
Water Vapor (100$^{\circ}$)	1.3×10^{-2}

Self-Assessment Questions:

1. What is viscosity, and how does it relate to fluid friction?
2. Describe the relationship between fluid velocity and fluid friction.

7.2.1 Derive an expression for terminal velocity of spherical body:

Stokes' law describes the drag force experienced by a small spherical object moving through a viscous fluid. The drag force acting on the object is directly proportional to its velocity and the viscosity of the fluid, and it is given by the equation:

$$\text{Drag Force} = 6\pi\eta r v \dots \dots (7.2)$$

where:

Drag Force is the force experienced by the object due to the fluid drag (measured in newtons, N).

η (eta) is the dynamic viscosity of the fluid (measured in Pascal-seconds, Pa·s or N·s/m²).

r is the radius of the spherical object (measured in meters, m).

v is the velocity of the object relative to the fluid (measured in meters per second, m/s).

The terminal velocity of a spherical body occurs when the drag force equals the gravitational force acting on the object. At terminal velocity, the net force on the body is zero, resulting in constant velocity.

Considering the gravitational force given by:

$$\text{Gravitational Force} = (4/3)\pi r^3 \rho g$$

where:

ρ (rho) is the density of the spherical body (measured in kilograms per cubic meter, kg/m³).

g is the acceleration due to gravity (measured in meters per second squared, m/s²).

At terminal velocity, the drag force is equal to the gravitational force, so we can equate the two expressions:

$$6\pi\eta r v = (4/3)\pi r^3 \rho g$$

Simplifying the equation:

$$6\eta v = (4/3)r^2 \rho g$$

Dividing both sides by 6η :

$$v = (2/9)(r^2 \rho g) / \eta \dots \dots (7.3)$$

This equation gives us the expression for the terminal velocity of a small spherical body moving through a viscous fluid according to Stokes' law. The terminal velocity is directly proportional to the square of the radius of the body (r^2), the density of the body (ρ), and the acceleration due to gravity (g), and inversely proportional to the dynamic viscosity of the fluid (η).

Self-Assessment Questions:

1. What factors affect terminal velocity?
2. Does the mass of an object affect its terminal velocity?

Worked Example 7.1

Calculate the terminal velocity of a raindrop of radius 0.2 cm. (Density of water 1000 kg/m^3 and that of air 1 kg/m^3).

Solution:

Step 1:

$$r = 0.2 \text{ cm}$$

$$V_t = ?$$

Step 2:

$$v_t = \frac{2gr^2}{9\eta} (\rho - \sigma)$$

Step 3:

$$v_t = \frac{2 \times 9.8 \times (0.2 \times 10^{-2})^2 \times 999}{9 \times 10^{-3}}$$

$$V_t = 8.7 \text{ m/s}$$

7.3 Fluids in Motion:

Fluids can move or flow in many ways. Water may flow smoothly and slowly in a quiet stream or violently over a water fall. The air may form a gentle breeze or a raging tornado. To deal with such diversity, it is necessary to classify some of the basic types of fluid flows.

7.3.1 Types of Fluids:

In **steady flow** the velocity of the fluid particles at any instant is constant as time passes. Every particle passing through certain point has the same velocity whereas at another location the velocity may vary, or as in river, which usually flows fastest near its center and slowed near its banks.

Streamline flow:

When a fluid flows slowly as shown along a pipe, the flow is said to be steady and lines are called streamlines. In figure (a) 7.2, they are parallel to the walls of the pipe. A streamline is a line drawn in the fluid such that a tangent to the stream – line at any point is parallel to the fluid velocity at that point. The fluid velocity can vary (in both magnitude and direction) from point to point along a streamline, but at any

given point, the velocity is constant in time, as required by the condition of steady flow. Such steady flow of fluid is called **streamline flow OR Laminar flow**

Laminar flow refers to the smooth, orderly movement of a fluid in which layers of the fluid slide past each other in parallel. In laminar flow, the fluid moves in well-defined streamlines without

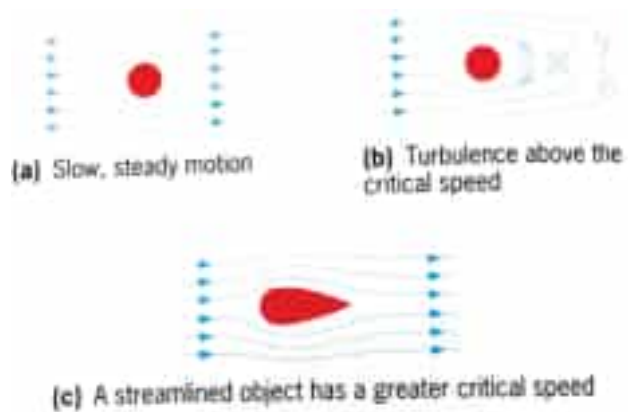

Fig: 7.2 types of fluid flow

any significant mixing or turbulence. This type of flow is characterized by a low Reynolds number, indicating a relatively slow and viscous flow.

Key characteristics of laminar flow include:

- Streamline Flow
- Smooth Velocity Profile
- Low Mixing and Diffusion
- Low Shear Stress
- Predictable Flow Behavior

Laminar flow is commonly observed in situations with low flow rates, small pipe diameters, and high fluid viscosity. It can be found in applications such as certain laboratory experiments, microfluidic devices, and some industrial processes that require precise control of fluid motion.

Unsteady flow:

Unsteady flow refers to the flow of a fluid that changes with time. In unsteady flow, the properties of the fluid, such as velocity, pressure, and density, vary at different locations and change over time. This is in contrast to steady flow, where the fluid properties remain constant at any given location.

Unsteady flow can occur in various fluid systems and is often associated with dynamic or transient conditions. Some examples of situations that involve unsteady flow include:

Water waves, Pulsatile blood flow, Pipe filling and draining, Turbulent flow etc.

Understanding unsteady flow is crucial in various engineering applications, such as the design of pipelines, pumps, turbines, and environmental fluid dynamics. It allows engineers and scientists to study the transient behavior of fluids and analyze the effects of time-varying flow conditions on system performance and stability

Incompressible fluid flow:

Mostly liquids are incompressible during which density of fluid remains constant even with varying pressure. In contrast, gases are highly compressible. However, there are certain situations in which the density of a flowing gas remains constant enough that the flow can be considered incompressible.

Non-viscous fluid flow:

An incompressible, non-viscous fluid is called an *ideal fluid*, with zero viscosity flows in an unhindered manner with no dissipation of energy. Although no real fluid has zero viscosity at normal temperatures, some fluids have negligibly small viscosities.

7.3.2 Transition from Laminar to turbulent flow:

In laminar flow, the streamlines of a fluid follow smooth paths. In contrast, for a fluid in turbulent flow, vortices form, detach and, propagate. When viscous or laminar flow exceeds certain limit is said to be transforming from laminar to turbulent. Just look at cigarette smoke undergoes a transition from laminar to turbulent flow. What is the criterion that determines whether flow is laminar or turbulent?

In 19th century Reynolds investigated the conditions that would give turbulence in the flow of a fluid. **Reynolds number**, Re , which is *the ratio of the typical inertial force to the viscous force and thus is a pure dimensionless number*. The inertial force has to be proportional to the density, ρ , and the typical velocity of the fluid, \bar{v} , because of rate of change of momentum i.e. $F = \frac{dp}{dt}$. The viscous force is proportional to the viscosity ' η ' and inversely proportional to the characteristic length scale 'L' over which the flow varies. For flow through a pipe with a circular cross-section, this length scale is the diameter of the pipe, $L = 2r$. Thus, the formula for calculating the Reynolds number is

$$\text{Kinematics Viscosity} = \frac{\text{Dynamic Viscosity}}{\text{Fluid density}}$$

$$\text{Reynolds no} = \frac{\text{Fluid velocity} \times \text{Internal diameter}}{\text{Kinematic Viscosity}}$$

$$Re = \frac{\rho \bar{v} L}{\eta} \dots\dots(7.4)$$

The velocity of liquid flow is given by

$$V = \frac{Re \eta}{2\rho} \dots\dots(7.5)$$

V = Speed of fluid

r = radius

η = Viscosity

ρ = fluid density

Re = Reynolds Number

The Reynolds number is important in analyzing the type of flow, when there is substantial velocity gradient. The flow is determined by using following standards:

- . **Laminar** when $Re < 2300$
- . **Transient** when $2300 < Re < 4000$

Transient flow, is flow where the flow velocity and pressure are changing with time. When changes occur to a fluid system such as the starting or stopping of a pump, closing or opening a valve, or changes in tank levels, then transient flow conditions exist: otherwise the system is steady state.

- . **Turbulent** when $4000 < Re$

The flow of liquid can easily be demonstrated with the apparatus shown in figure 7.3. A dye flows from the tube into the tank and by altering the pressure head the flow can be made either turbulent or laminar. As you can see in figure 7.3, the flow becomes turbulent when the line ceases to be straight.

DO YOU KNOW?

Make a small hole near the bottom of an open tin can. Fill the can with water, which then proceeds to spurt from the hole. If you cover the top of the can firmly with the palm of your hand, the flow stops.

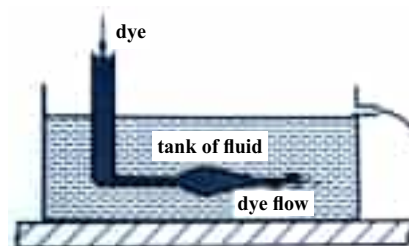

Fig: 7.3

The streamlining of bodies are most important in the design of cars, submarines and nose cones of aircrafts and rockets, since a reduction in drag can reduce vibration and also save large amounts of fuel. Figure 7.4 shows the best shapes for rocket cones for the *subsonic*, *supersonic* and *hypersonic* flight respectively.



subsonic supersonic hypersonic

Fig: 7.4

Worked Example 7.2

The volume rate of an air conditioning system to be $3.84 \times 10^{-3} \text{ m}^3/\text{s}$. The air is sent through an insulated, round conduit with a diameter of 18 cm. This calculation assumed laminar flow. (a) Was this a good assumption? (b) At what velocity would the flow become turbulent?

Solution:

Step 1:

$$\text{Volume rate} = 3.84 \times 10^{-3} \text{ m}^3/\text{s}.$$

$$\eta \text{ of air} = 0.0181 \text{ m Pa}\cdot\text{s}$$

$$\rho \text{ of air} = 1.23 \text{ kg/m}^3$$

$$\text{diameter} = 18 \text{ cm}$$

$$\text{Velocity} = ?$$

Step 2:

$$\text{Volume rate} = Av$$

$$3.84 \times 10^{-3} = \pi (0.09) v$$

$$v = 0.15 \text{ m/s}$$

Step 3:

$$R_e = \frac{2\rho v r}{\eta}$$

$$R_e = \frac{2 \times (1.23) \times 0.15 \times 0.09}{0.0181 \times 10^{-3}}$$

$$R_e = 1835$$

Since the Reynolds number is $1835 < 2000$, the flow is laminar and not turbulent. The assumption that the flow was laminar is valid.

Step 4:

To find the maximum speed of the air to keep the flow laminar, consider the Reynolds number

$$R_e = \frac{2\rho v r}{\eta} \leq 2000$$

$$v = \frac{2000(0.0181 \times 10^{-3})}{2(1.23)(0.09)}$$

$$v = 0.16 \text{ m/s}$$

Significance:

When transferring a fluid from one point to another, it is desirable to limit turbulence. Turbulence results in wasted energy, as some of the energy intended to move the fluid is dissipated when eddies are formed. In this case, the air conditioning system will become less efficient once the velocity exceeds 0.16 m/s, since this is the point at which turbulence will begin to occur.

7.3.3 Fluid flow and resistance to motion in fluids involve turbulent rather than laminar conditions:

In practical examples of fluid flow and resistance to motion in fluids, turbulent conditions are more prevalent than laminar conditions. Turbulent flow is a type of fluid motion characterized by chaotic and irregular movement of fluid particles, resulting in whirlpool, fluctuations in velocity and pressure. On the other hand, laminar flow is smooth, ordered, and occurs in layers without any significant mixing or swirling.

Several factors contribute to the prevalence of turbulent flow in practical scenarios:

High Reynolds Numbers: Turbulent flow is more likely to occur at higher Reynolds numbers, which is a dimensionless parameter that measures the ratio of inertial forces to viscous forces in the fluid. In many real-world applications, such as in industrial processes, transportation, and natural phenomena like rivers and atmospheric flows, the Reynolds numbers are often large enough to induce turbulent behavior.

Rough Surfaces: When fluid flows over rough surfaces, such as in pipes, channels, or around objects, it can lead to turbulent flow due to the disruption of the fluid layers. Turbulence enhances the mixing of fluid components and affects the resistance to motion.

High Velocities: High flow velocities can promote turbulent behavior, especially in situations where the fluid encounters sudden changes in cross-sectional area or flow direction as shown in figure b.

Agitation and Stirring: In industrial processes, mixing, and agitation systems, turbulent flow is deliberately induced to ensure efficient mixing of substances and heat transfer.

Pressure Gradients: Rapid changes in pressure along the flow path can lead to turbulent flow patterns, as the fluid tries to adjust to the varying conditions.

DO YOU KNOW?



Smoke rises smoothly for a while and then begins to form swirls and eddies. The smooth flow is called laminar flow, whereas the swirls and eddies typify turbulent flow. Smoke rises more rapidly when flowing smoothly than after it becomes turbulent, suggesting that turbulence poses more resistance to flow.



Fig: 7.5



Fig: 7.6

Laminar flow



Turbulent flow



Fig: 7.7

Examples of practical situations involving turbulent flow include:

- Airflow around vehicles, airplanes, and wind turbines as depicted in figure a.
- Fluid flow in pipes, especially in scenarios with high flow rates or rough internal surfaces as shown in figure c.
- Rivers and streams, where the irregularities in the bed and banks induce turbulence.
- Ocean currents and waves, which often involve turbulent motion.
- Mixing processes in chemical reactors, industrial tanks, and bioreactors.
- Combustion in engines and furnaces, where turbulent mixing of fuel and air improves combustion efficiency.

While laminar flow can occur in specific situations, such as slow and smooth flow in small tubes or in some laboratory setups, turbulent flow dominates in most real world fluid flow applications due to its complex and dynamic behavior, which significantly influences resistance to motion and various other fluid phenomena.

7.4 Equation of Continuity:

Suppose a steady laminar flow of a fluid through an enclosed tube or pipe as shown in figure the speed of the fluid varies with the diameter of the tube variation. The mass flow rate which follows the **law conservation of mass** is defined as **the mass Δm of fluid that passes at given point per unit time Δt :**

$$\text{mass flow rate} = \frac{\Delta m}{\Delta t} \dots\dots(7.6)$$

In figure 7.8, the volume of a fluid passing through area A_1 in a time Δt is $A_1\Delta l_1$, where Δl_1 is the distance the fluid moves in time Δt . The velocity of fluid passing through A_1 is $v_1 = \Delta m_1 / \Delta t$. Then the mass flow rate:

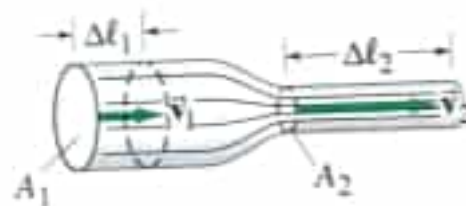

Fig: 7.8

$$\begin{aligned} \frac{\Delta m_1}{\Delta t} &= \frac{\rho_1 \Delta V_1}{\Delta t} \\ &= \frac{\rho_1 A_1 \Delta l_1}{\Delta t} = \rho_1 A_1 v_1 \end{aligned}$$

Where $\Delta V_1 = A_1\Delta l_1$ is the volume of mass Δm . Similarly, through A_2 , the flow rate is $\rho_2 A_2 v_2$. Since no fluid flows in or out the sides of the tube, the flow rates through A_1 and A_2 must be equal.

$$\frac{\Delta m_1}{\Delta t} = \frac{\Delta m_2}{\Delta t} \dots\dots(7.7)$$

and

$$\rho_1 A_1 v_1 = \rho_2 A_2 v_2$$

This is called the equation of continuity.

If the fluid is incompressible which is an excellent approximation for liquids under most circumstances, then $\rho_1 = \rho_2$, the equation of continuity is

$$A_1 V_1 = A_2 V_2 \quad (\rho \text{ is constant}) \dots\dots(7.8)$$

Unit 7: Fluid Dynamics

The product AV is the volume rate of flow which is defined as *the volume of fluid passing a given point per second*.

$$\frac{\Delta v}{\Delta t} = A \frac{\Delta l}{\Delta t} = Av \dots\dots(7.9)$$

Its SI unit is m^3/s .

The product of area and velocity is describing that where the cross-sectional area is large, the velocity is small, and where the area is small, the velocity is large.

Self-Assessment Questions:

1. State the equation of continuity in terms of fluid flow.
2. How does the equation of continuity relate to conservation of mass?
3. How does the velocity of a fluid change when it flows through a constricted pipe?

Worked Example 7.3

The radius of aorta is about 1.2 cm, and the blood passing through it has a speed of about 40 cm/s. A typical capillary has a radius of about 4×10^{-4} cm, and blood flows through it at a speed of about 5×10^{-4} m/s. Estimate the number of capillaries that are in the body.

Step 1:

radius of aorta = 1.2 cm

speed in = 40 cm/s

Capillary radius = 4×10^{-4} cm

Speed out = 5×10^{-4} m/s

No of capillaries = ?

Let A_1 be the area of the aorta and A_2 be the area of all the capillaries through which blood flows. Then $A_2 = N\pi r_{cap}^2$, where $r_{cap} = 4 \times 10^{-4}$ cm is the estimated average radius of one capillary. From equation of continuity, we have

$$\begin{aligned} v_2 A_2 &= v_1 A_1 \\ v_2 N \pi r_{cap}^2 &= v_1 \pi r_{aorta}^2 \\ N &= \frac{v_1 r_{aorta}^2}{v_2 r_{cap}^2} \end{aligned}$$

$$N = (0.40 \text{ m/s} / 5 \times 10^{-4}) (1.2 \times 10^{-2} \text{ m} / 4 \times 10^{-6} \text{ m})^2$$

$$N = 7 \times 10^9$$

on the order of billion capillaries.



Assume that blood density is same from aorta to capillaries. By equation of continuity, the volume flow rate in the aorta must equal the volume flow rate through all the capillaries. The total area of all the capillaries is given by the area of a typical capillary multiplied by the total number N of capillaries.

7.5 Bernoulli's Principle:

When a fluid is in motion the pressure within the fluid flow varies with velocity of the fluid for streamlined flow. This pressure variation is a consequence of Bernoulli's theorem proposed in 1740. Bernoulli's principle states that *the velocity of a fluid is high, the pressure is low, and the velocity is low, the pressure is high.*

7.5.1 Bernoulli's Equation:

Bernoulli's equation deals with energy conservation law for the steady-state flow of incompressible fluids, such as water. It relates the energy of the fluid in terms of its pressure, velocity, and height.

Bernoulli's equation can be derived from the first principle using the law of conservation of energy. According to energy conservation principles, energy can neither be created nor destroyed. Therefore, during streamline flow, the total mechanical energy remains constant. A few assumptions need to be made before deriving the equation.

Assumptions

- The flow must be steady and streamline.
- The fluid is incompressible the density should remain constant at all points during the flow.
- There are no viscous forces in the fluid, and friction is negligible.

Consider a pipe whose diameter and elevation change as a fluid passes through it. Consider a small mass of the fluid with density ρ that flows from point 1 to 2 as shown in figure 7.9. The work done by a force F on the fluid to displace it by an infinitesimal distance Δx is given by,

$$W = F\Delta x$$

Therefore, at points 1 and 2, the work done are,

$$\Delta W_1 = F_1\Delta x_1$$

$$\Delta W_2 = F_2\Delta x_2$$

Total work done when the fluid moves 1 to 2 is,

$$\Delta W = \Delta W_1 - \Delta W_2$$

$$\text{or, } \Delta W = F_1\Delta x_1 - F_2\Delta x_2$$

Force is the product of pressure and area

($F = pA$), and the volume is the product of length and cross – sectional area

($V = Ax$). Therefore,

DO YOU KNOW?

When a truck moves very fast, it created a low pressure area, so dusts are being pulled along in the low pressure area. If we stand very close to railway track in the platform, when a fast train passes us, we get pulled towards the track because of the low pressure area generated by the sheer speed of the train.

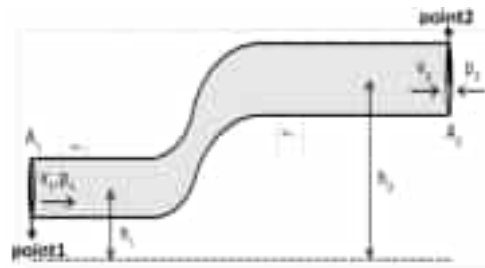

Fig: 7.9 fluid passthrough pipe

Unit 7: Fluid Dynamics

$$\Delta W = p_1 A_1 \Delta x_1 - p_2 A_2 \Delta x_2 = p_1 \Delta V - p_2 \Delta V = (p_1 - p_2) \Delta V$$

Now, when the fluid moves from point 1 to 2, there is a change of kinetic energy.

$$\Delta K.E = \frac{1}{2} m_2 v_2^2 - \frac{1}{2} m_1 v_1^2 = \frac{1}{2} \rho \Delta V v_2^2 - \frac{1}{2} \rho \Delta V v_1^2 = \frac{1}{2} \rho \Delta V (v_2^2 - v_1^2) \dots\dots(7.10)$$

Similarly, the change in potential energy is given by,

$$\Delta U = mgh_2 - mgh_1 = \rho \Delta V g (h_2 - h_1) \dots\dots(7.11)$$

The work done in moving the fluid is the sum of the change in kinetic and potential energies.

$$\Delta W = \Delta K.E + \Delta U$$

$$\text{or, } (p_1 - p_2) \Delta V = \frac{1}{2} \rho \Delta V (v_2^2 - v_1^2) + \rho \Delta V g (h_2 - h_1)$$

$$\text{or, } p_1 - p_2 = \frac{1}{2} \rho (v_2^2 - v_1^2) + \rho g (h_2 - h_1)$$

$$p_1 + \frac{1}{2} \rho v_1^2 + \rho g h_1 = p_2 + \frac{1}{2} \rho v_2^2 + \rho g h_2$$

$$\text{or, } p + \frac{1}{2} \rho v^2 + \rho g h = \text{constant}$$

This is Bernoulli's equation.

Therefore

$$P + \frac{1}{2} \rho v^2 + \rho g h = \text{Constant} \dots\dots(7.12)$$

The height h is measured from some convenient reference level, for example at the surface of the liquid. The equation is really a statement of conservation of energy per unit volume in the fluid.

- $\frac{1}{2} \rho v^2 + \rho g h$ is total pressure.
- $\rho g h$ is static pressure.
- $\frac{1}{2} \rho v^2$ is dynamic pressure.

Worked Example 7.4

Water leaves the jet of a horizontal hose at 10 m/s, if the velocity of water within the hose is 0.4 m/s, calculate the pressure P within the hose. (Density of water 1000 kg/m³ and atmospheric pressure is 100000 Pa).

Solution:

Step 1:

$$V_1 = 10 \text{ m/s}$$

$$V_2 = 0.4 \text{ m/s}$$

$$P = ?$$

$$\text{Density of water} = 1000 \text{ kg/m}^3$$

$$\text{Atmospheric Pressure} = 100000 \text{ Pa}$$

Step 2:

Here $h_1 = h_2$, so Bernoulli's equation becomes

$$P_1 + \frac{1}{2} \rho V_1^2 = P_2 + \frac{1}{2} \rho V_2^2$$

Step 3:

$$100000 + \frac{1}{2} \times 1000 \times 100 = P_2 + \frac{1}{2} \times 1000 \times 0.16$$

$$P_2 = 1.5 \times 10^5 \text{ Pa}$$

7.5.2 Applications of Bernoulli's Principle:

Bernoulli's principle, also known as the Bernoulli effect, describes the relationship between fluid velocity and pressure in a flowing fluid. It states that in an ideal, incompressible, and non-viscous fluid, the sum of the fluid's kinetic energy (velocity) and potential energy (pressure) remains constant along a streamline. This principle has various practical applications, including those mentioned in your question:

Filter Pump: In a filter pump, Bernoulli's principle is applied to increase the pressure of the fluid passing through the pump. By reducing the cross-sectional area of the pump's outlet, the fluid's velocity increases according to the principle, leading to a decrease in pressure (as kinetic energy increases). This pressure drop helps draw fluid into the pump and through the filter medium, facilitating the filtration process.



Fig: 7.10
Filter pump

Venturi Meter: A Venturi meter is a device used to measure the flow rate of a fluid in a pipe. It consists of a gradually narrowing tube (Venturi tube) inserted in the pipe. As the fluid flows through the narrowing section, its velocity increases according to Bernoulli's principle, and the pressure decreases. By measuring the pressure difference between the narrowest section and the wider parts of the pipe, the flow rate can be determined.

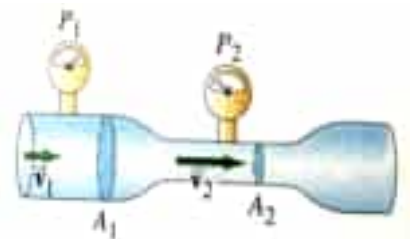

Fig: 7.11 Venturi meter

Atomizer: Atomizers are devices used to convert liquids into fine sprays or mists. The application of Bernoulli's principle is crucial in this process. As the liquid passes through a small nozzle in the atomizer, its velocity increases, leading to a decrease in pressure according to the principle. This decrease in pressure facilitates the breakup of the liquid into tiny droplets or a fine spray.



Fig: 7.12 Atomizer

DO YOU KNOW?

Why does smoke go up a chimney?

It's partly because hot air rises as it's less dense and therefore buoyant. When wind blows across the top of a chimney, the pressure is less there than inside the house. Hence, air and smoke are pushed up the chimney by the higher indoor pressure. Even on an apparently still night there is usually enough ambient air flow at the top of a chimney to assist upward flow of smoke.



Flow of Air over an Aerofoil: When air flows over an aerofoil (such as the wing of an aircraft), the shape of the aerofoil causes the air to travel faster over the top surface compared to the bottom surface. According to Bernoulli's principle, the air pressure decreases over the top surface due to the increased velocity, creating a pressure difference that results in lift, allowing the aircraft to stay airborne

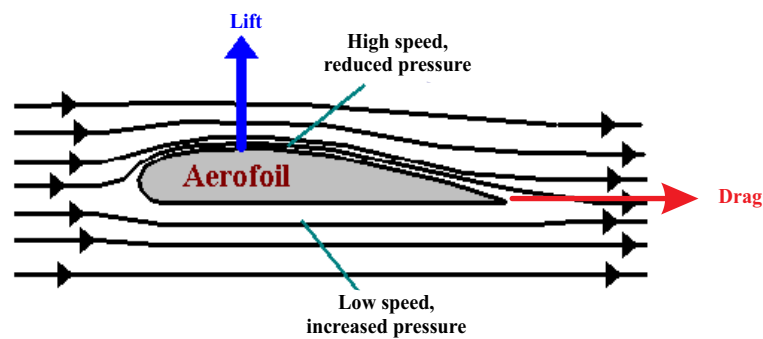

Fig: 7.13 An aerofoil

Blood Physics: In the circulatory system, Bernoulli's principle is applicable to the flow of blood through blood vessels, particularly in areas of constriction or stenosis. When the diameter of a blood vessel narrows, the blood velocity increases, leading to a decrease in pressure, which can have clinical implications in conditions such as atherosclerosis or stenosis.

It's essential to note that while Bernoulli's principle is an excellent theoretical tool for understanding fluid behavior in these applications, real-world fluids may have additional complexities, such as viscosity and compressibility, which need to be considered for precise calculations and analyses.

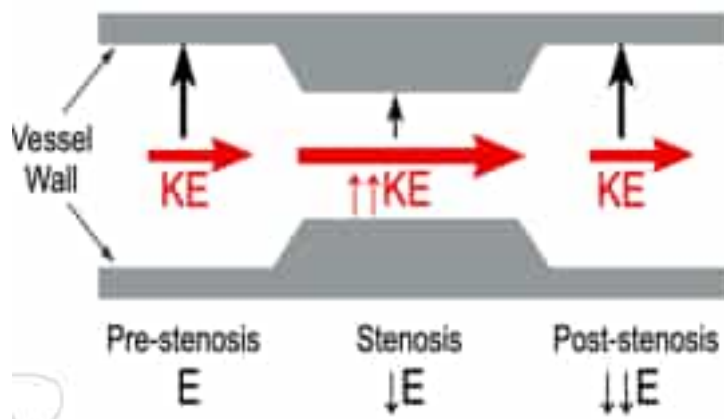
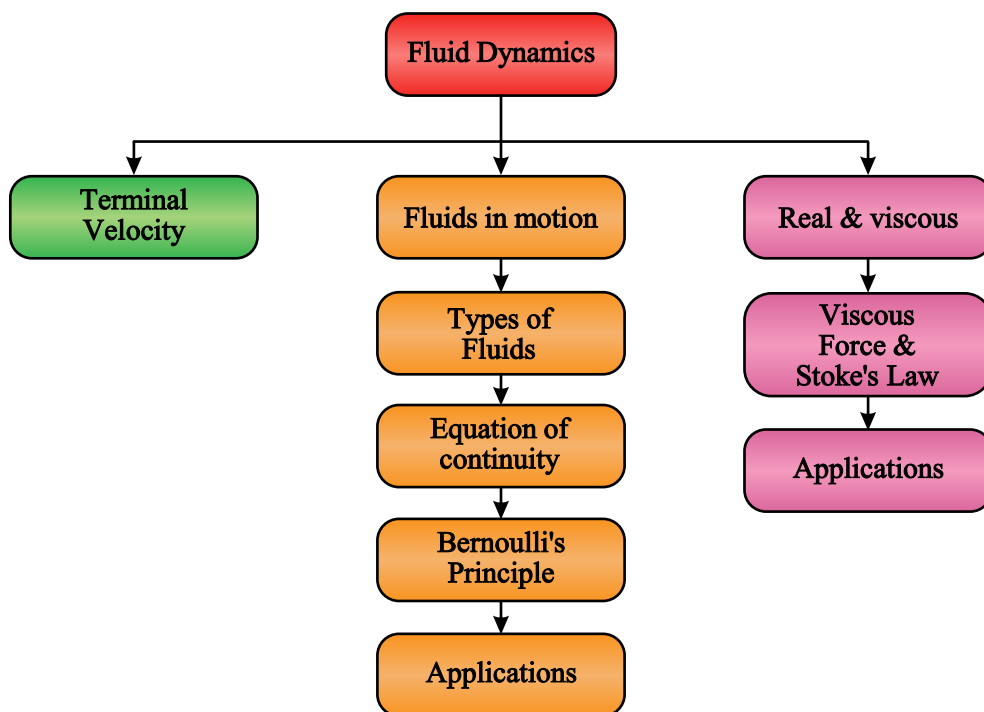

Fig: 7.14 Stenosis or pre stenosis of blood vessels walls



SUMMARY

- The physics of fluids in motion is Fluid Dynamics:
- A frictional force between adjacent layers of fluid as the layers move past one another is called Viscosity:
- The rate of change of velocity with distance normal to the direction of flow of the layers of the fluid with respect to object passing through the fluid is known as Velocity Gradient:
- When fluid resistance of a falling object equals its weight, the net force is zero and no further acceleration occurs is called Terminal Velocity:
- The velocity of the fluid particles at any is constant as time passes is called Steady flow: Whenever the velocity at a point in the fluid changes as time passes, such flow becomes turbulent is known as unsteady flow:
- An incompressible, non-viscous fluid is called an *ideal fluid*,
- The sliding of layers of fluid parallel and smoothly to direction of flow is Laminar Flow:
- The ratio of the typical inertial force to the viscous force and thus is a pure dimensionless number is called Reynolds Number:
- The velocity of a fluid is high, the pressure is low, and the velocity is low, the pressure is high is known as Bernoulli's Principle:





EXERCISE

Section (A): Multiple Choice Questions (MCQs)

- For an incompressible fluid, the flow rate is
 - equal for all surfaces.
 - constant throughout the pipe.
 - greater for the larger parts of the pipe.
 - none of the above
- Bernoulli's principle states that for horizontal flow of a fluid through a tube, the sum of the pressure and energy of motion per unit volume is
 - increasing with time
 - decreasing with time
 - constant
 - varying with time
- Which of the following is associated with the law of conservation of energy in fluids?
 - Archimedes' principle
 - Bernoulli's principle
 - Pascal's principle
 - equation of continuity
- As the speed of a moving fluid increases, the pressure in the fluid
 - increases
 - remains constant
 - decreases
 - may increase or decrease, depending on the viscosity
- If the cross-sectional area of a pipe decreases, what happens to the fluid velocity?
 - Increases
 - Decreases
 - Remains the same
 - Depends on the fluid density
- A sky diver falls through the air at terminal velocity. The force of air resistance on him is
 - half his weight
 - equal to his weight
 - twice his weight
 - Cannot be determined from the information given.
- Wind speeding up as it blows over the top of a hill
 - Increases atmospheric pressure there.
 - decreases atmospheric pressure there.
 - doesn't affect atmospheric pressure there.
 - equal's atmospheric pressure.

8. A fluid is undergoing “incompressible” flow. This means that:
 - a) the pressure at a given point cannot change with time
 - b) the velocity at a given point cannot change with time
 - c) the velocity must be the same everywhere
 - d) the pressure must be the same everywhere
 - e) the density cannot change with time or location

9. A fluid is undergoing steady flow. Therefore:
 - a) the velocity of any given molecule of fluid does not change
 - b) the pressure does not vary from point to point
 - c) the velocity at any given point does not vary with time
 - d) the density does not vary from point to point

10. The equation of continuity for fluid flow can be derived from the conservation of:
 - a) energy
 - b) mass
 - c) volume
 - d) pressure

Section (B): Structured Questions

CRQ's:

1. What is difference between streamline and turbulent flow?
2. Would a drinking straw work in space where there is no gravity? Explain.
3. Why do airplanes take off into wind?
4. Describe terminal velocity in liquids.
5. Discuss the significance of Reynolds number.
6. State Bernoulli's principle.
7. Give two applications of Bernoulli's principle.
8. 'Fluid flow is turbulent rather than laminar', support this statement.
9. Discuss importance of Stokes law.
10. Justify spin of ball in Bernoulli's principle.

ERQ's:

1. Derive equation of continuity. Also show its physical significance.
2. Derive Bernoulli's equation.
3. Discuss viscous force in fluids.
4. Define fluid dynamics and explain its significance in the study of fluids. How does it differ from fluid statics?
5. Discuss the concept of Reynolds number and its significance in fluid dynamics. Explain how Reynolds number relates to the transition between laminar and turbulent flow.

Numericals:

- Two spherical raindrops of equal size are falling through air at a velocity of 0.08 m/s. If the drops join together forming a large spherical drop, what will be the new terminal velocity? **(0.13 m/s)**
- Calculate the viscous drag on a drop of oil of 0.1 mm radius falling through air at its terminal velocity. (Viscosity of air = 1.8×10^{-5} Pa. s; density of oil = 850 kg / m^3) **(3.48×10^{-8} N)**
- What area must a heating duct have if air moving 3.0 m/s along it can replenish the air every 15 minutes in a room of volume 300 m^3 . Assume air density remains constant. **(0.11 m^2 , 0.33 m)**
- Water circulates throughout a house in a hot-water heating system. If the water is pumped at a speed of 0.50 m/s through a 4.0 cm diameter pipe in the basement under a pressure of 3.0 atm, what will be the flow speed and pressure in a 2.6 cm diameter pipe on the second floor 5.0 m above? Assume the pipes do not divide into branches. **(1.2 m/s , 2.5 atm)**
- What is the volume rate of flow of water from a 1.85 cm diameter faucet if the pressure head is 12 m? **($4.6 \times 10^{-3} \text{ m}^3/\text{s}$)**
- The stream of water emerging from a faucet ‘neck down’ as it falls. The cross-sectional area is 1.2 cm^2 and 0.35 cm^2 . The two levels are separated by a vertical distance of 45 mm as shown in figure. At what rate does water flow from the tap? **($34 \text{ cm}^3 / \text{s}$)**
- Water leaves the jet of a horizontal hose at 10 m/s. If the velocity of water within the hose is 0.40 m/s, calculate the pressure within the hose. Density of water is 1000 kg/m^3 and atmospheric pressure is 100000 Pa. **($1.5 \times 10^5 \text{ Pa}$)**
- What is the maximum weight of an aircraft with a wing area of 50 m^2 flying horizontally, if the velocity of the air over the upper surface of the wing is 150 m/s and that the lower surface 140 m/s? Density of air is 1.29 kg/m^3 **($9.3 \times 10^4 \text{ N}$)**
- A liquid flows through a pipe with a diameter of 0.50 m at a speed of 4.20 m/s. What is the rate of flow in L/min? **(49500 L/min)**
- Calculate the average speed of blood flow in the major arteries of the body, which have a total cross-sectional area of about 2.1 cm^2 . Use the data of example **(13.6 cm/s)**



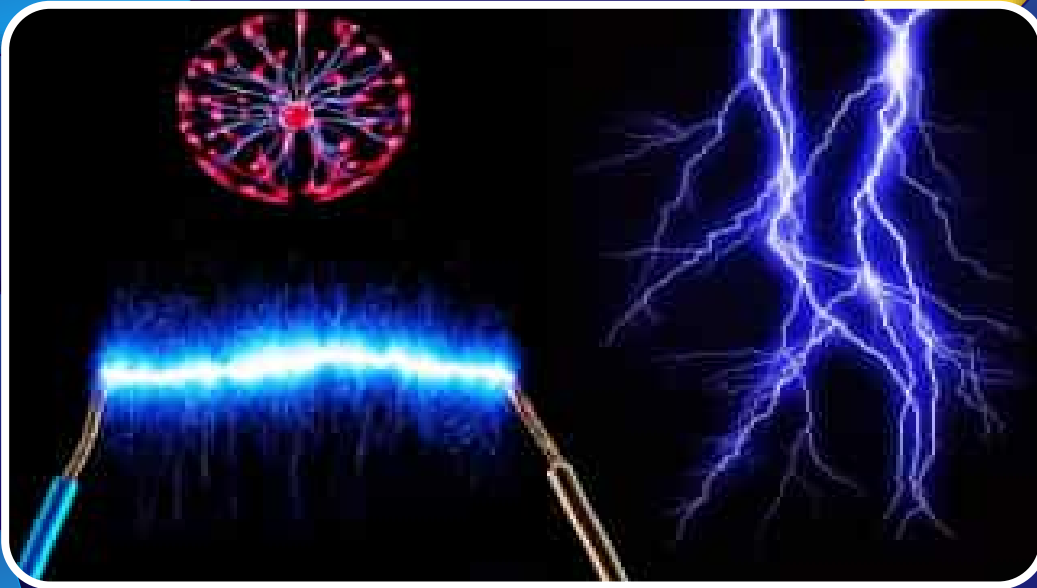

In this unit student should be able to:

- Define Electrostatic force
- Explain Coulomb's law
- Define the Coulomb's force in different mediums
- Solve problems using Coulomb's law
- Describe the concept of an electric field as an example of a field of force.
- Derive the expression $\vec{E} = \frac{1}{4\pi\epsilon_0} \frac{q}{r^2}$ for the magnitude of electric field at a distance 'r' from a point charge 'q'.
- Define electric field strength as a force per unit positive charge.
- Solve problems and analyze information using $\vec{E} = \frac{F}{q}$.
- Solve problems involving the use of the expression, $\vec{E} = \frac{1}{4\pi\epsilon_0} \frac{q}{r^2}$
- Describe the concept of electric dipole
- Calculate the magnitude and direction of the electric field at a point due to two charges with the same or opposite signs.
- Sketch the electric field lines for two point-charges of equal magnitude with the same or opposite signs.
- Describe electric flux.
- Explain electric flux through a surface enclosing a charge.
- Define absolute electric potential.
- Define potential difference and its unit.
- Solve problems by using the expression $V=W/q$.
- Calculate the potential in the field of a point charge using the equation,

$$V = \frac{1}{4\pi\epsilon_0} \frac{q}{r}$$
- Show that the electric field at a point is given by the negative potential gradient at that point.
- Solve problems by using the expression, $E=-V/d$
- Define electron volt.

8.1.1 Electrostatic force:

In the early days, the early Greek philosophers has studied the physics of electrostatic by performing an activity; when amber is rubbed with silk or wool and brought near dust particles, the dust particles will jump to stick with the amber. This attraction between dust particles and amber is known as an electrostatic force.

The electrostatic force between two charges is analogy to the gravitational force. Two charged objects can (i) attract or (ii) repel each other with a force is known as electrostatic force.

Whereas the gravitational force is always attractive in nature. Furthermore, the electrostatic forces are short range forces as compare to the gravitational forces, but the electrostatic forces are strong forces than the gravitational forces.

The object having same nature of charges repel each other and having opposite nature attract each other with an electrostatic force.

8.1.2 Coulomb's Law:

Charles-Augustin de Coulomb performed an experiment of torsion balance (see figure 8.1) in 1785 to measure the magnitudes of the electric force between charged objects. Once the spheres are charged by rubbing, the electric force between them is very large compared with the gravitational attraction, and so the gravitational force can be neglected. From Coulomb's experiments, we can generalize the properties of the electric force (sometimes called the electrostatic force) between two stationary charged particles.

- If two charged particles are brought near each other, they exert an electrostatic force on each other. The direction of the force vectors depends on the signs of the charges.
- If the particles have the same sign of charge, they repel each other. That means that the force vector on each is directly away from the other particle. Beside this,

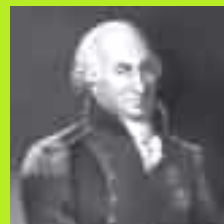
DO YOU KNOW?

- Name: Charles-Augustin de Coulomb
- Birth Year: 1736
- Birth date: June 14, 1736
- Birth City: Angoulême
- Birth Country: France
- Gender: Male
- Best Known For: French engineer and physicist Charles de Coulomb made pioneering discoveries in electricity and magnetism, and came up with the theory called Coulomb's Law.

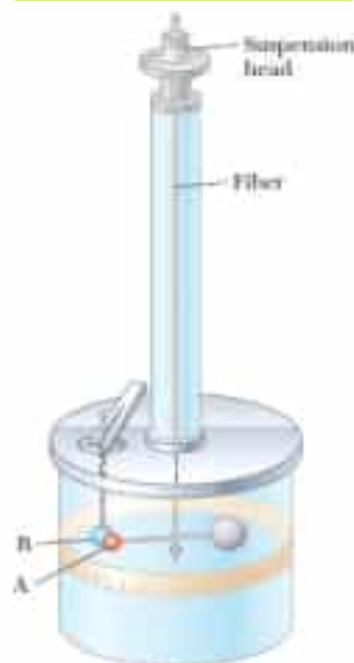

Fig: 8.1
Coulomb's torsion balance.

- If the particles have opposite signs of charge, they attract each other and the force vector on each is directly towards the other particle as shown in figure 8.2.



Fig: 8.2 (a) both are positive

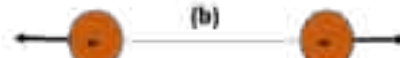

Fig: 8.2 (b) both are negative..

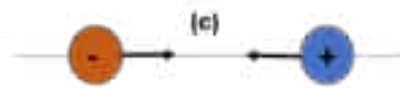

Fig: 8.2 (c) both are opposite

The illustration for two charges (q_1, q_2) and separation (r) between the charges is shown in figure 8.3.



Fig: 8.3

Two charges q_1 and q_2 placed at a distance r from each other.

The electrostatic force F is directly proportional to the product of magnitudes of the charges q_1 and q_2 . And inversely proportional to the square of the distance r between the charges and

$$\vec{F} \propto q_1 q_2$$

$$\vec{F} \propto \frac{1}{r^2}$$

This result is known as the inverse square law.

$$\vec{F} = k \frac{q_1 q_2}{r^2}$$

Where k is known as the Coulomb's constant and $k = \frac{1}{4\pi\epsilon_0}$.

$$\vec{F} = \frac{1}{4\pi\epsilon_0} \frac{q_1 q_2}{r^2} \quad (8.1)$$

8.1.3 Coulomb's force in different medium:

The permittivity of air at standard pressure is only about 1.005 times that of ϵ_0 . Therefore, it can be assumed in many cases that the values of ϵ_0 are equal for both vacuum and air. The permittivity of water is about eighty times that of a vacuum. Thus, the force between charges situated in water is eighty times less than if they were situated the same distance apart in a vacuum.

In general, the equation (8.1) can rewrite as

$$\vec{F} = \frac{1}{4\pi\epsilon} \frac{q_1 q_2}{r^2}$$

where $\epsilon = \epsilon_r \epsilon_0$ is the permittivity of the medium and ϵ_r is the relative permittivity.

DO YOU KNOW?

For your information

ϵ_0 is known as the permittivity of free space. if we suppose the charges are situated in a vacuum then the value of ϵ_0 is given as $\epsilon_0 = 8.854 \times 10^{-12} \text{ C}^2/\text{N m}^2$. The value of Coulomb's constant in SI unit is given as $k = 8.988 \times 10^9 \text{ N m}^2/\text{C}^2$

Material	Relative Permittivity
Vacuum	1.0000
Air	1.0006
PTFE, FEP (Teflon)	2.0
Polympropylene	2.20 to 2.28
Polystyrene	2.4 to 3.2
Wood (Oak)	3.3
Bakelite	3.5 to 6.0
Wood (Maple)	4.4
Glass	4.9 to 7.5
Wood (Birch)	5.2
Glass-Booded Mica	6.3 to 9.1
Porcelain, Siacite	6.5

DO YOU KNOW?
Why do salt crystals dissolve in water?

A salt crystal is an ionic crystal. For example, in the case of sodium chloride (NaCl). The sodium ions (Na⁺) and the chlorine ions (Cl⁻) in a salt crystal are oppositely charged. The electrostatic forces between these ions hold the atoms together. Note that Coulomb's law as stated above applies strictly to a vacuum. In terms of the force between two-point charges in air, the force is effectively the same as it would be in a vacuum.

Vector form of Coulomb's law:

Figure 8.4 illustrates the vector form of electrostatic force between two charges. The electric force F_{12} exerted by a charge q_1 on other charge q_2 is written as:

$$\vec{F}_{12} = \frac{1}{4\pi\epsilon} \frac{q_1 q_2}{r^2} \hat{r}_{12} \quad (8.2)$$

where \hat{r}_{12} is a unit vector directed from q_1 toward q_2 as shown Figure 8.4. Because the electric force obeys Newton's third law, as equal and opposite direction; that is, $\vec{F}_{12} = -\vec{F}_{21}$

Fig: 8.4

The force F_{21} exerted by q_2 on q_1 is equal in magnitude and opposite in direction to the force F_{12} exerted by q_1 on q_2 .

Worked Example 8.1

The electron and proton of a hydrogen atom (**figure A**) are separated by approximately $5.3 \times 10^{-11} \text{ m}$. Find the magnitudes of (a) the electric force and (b) the gravitational force between the two particles. (c) What is your conclusion about these forces.

Solution:

Step:1 Write down the known quantities and quantities to be found.

$$r = 5.3 \times 10^{-11} \text{ m}.$$

- (a) Charge on electron = $q_e = -1.602 \times 10^{-19} \text{ C}$,
 Charge on proton = $q_p = 1.602 \times 10^{-19} \text{ C}$,
 $k = 8.988 \times 10^9 \text{ N m}^2/\text{C}^2$
 Electrostatic force = $F_e = ?$
- (b) Mass of electron = $m_e = 9.109 \times 10^{-31} \text{ kg}$
 Mass of proton = $m_p = 1.672 \times 10^{-27} \text{ kg}$.
 where $G = 6.67 \times 10^{-11} \text{ N m}^2/\text{kg}^2$,
 Gravitational force = $F_g = ?$

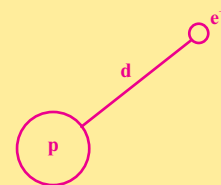
Figure A

Step:2 Write down the formula and rearrange if necessary.

(a) For electrostatic force $F_e = k \frac{q_e q_p}{r^2}$

(b) For gravitational force $F_g = G \frac{m_e m_p}{r^2}$

Step:3 Put the values in formula and calculate.

$$(a) F_e = 8.988 \times 10^9 \text{ N m}^2/\text{C}^2 \times \frac{-1.602 \times 10^{-19} \text{ C} \times 1.602 \times 10^{-19} \text{ C}}{(5.3 \times 10^{-11} \text{ m})^2}$$

$$F_e = -8.2 \times 10^{-8} \text{ N}$$

where negative sign indicates the force is attractive. The magnitude of this electrostatic force is $8.2 \times 10^{-8} \text{ N}$.

$$(b) F_g = 6.67 \times 10^{-11} \text{ N m}^2/\text{kg}^2 \frac{9.109 \times 10^{-31} \text{ kg} \times 1.672 \times 10^{-27} \text{ kg}}{(5.3 \times 10^{-11} \text{ m})^2}$$

$$F_g = 3.6 \times 10^{-47} \text{ N}$$

Hence, the gravitational force of attraction between the particles is $3.6 \times 10^{-47} \text{ N}$

(c) Conclusion:

The gravitational force between electron and proton is negligible as compared to the electric force, which implies that electric force is strong force.

Worked Example 8.2

Two positive charge of equal magnitude are placed of in vacuum at distance of 50cm and repel each other with the electric force of 0.1N. **(a)** Find the value of the charge. **(b)** Calculate the force between these two charges if they are places in an insulating liquid whose permittivity is five times that of a vacuum.

Solution:

Step:1 Write down the known quantities and quantities to be found.

$$r = 0.5 \text{ m}$$

$$F = 0.1 \text{ N}$$

$$\epsilon = 5\epsilon_0$$

(a) $q_1 = q_2 = q = ?$

(b) $F_{\text{liquid}} = ?$

Step:2 Write down the formula and rearrange if necessary.

$$(a) F = k \frac{q_1 q_2}{r^2} \Rightarrow q^2 = \frac{F \times r^2}{k}$$

$$(b) F_{\text{liquid}} = \frac{1}{4\pi\epsilon} \frac{q_1 q_2}{r^2} = \frac{1}{5 \times 4\pi\epsilon_0} \frac{q^2}{r^2}$$

$$F_{\text{liquid}} = \frac{1}{5} F$$

Step:3 Put the values in formula and calculate.

$$(a) q^2 = \frac{0.1 \times (0.5)^2}{8.988 \times 10^9}$$

$$q = 1.7 \times 10^{-7} \text{ C} = 0.17 \mu\text{C}$$

$$(b) F_{\text{liquid}} = \frac{0.1 \text{ N}}{5} = 0.02 \text{ N}$$

Hence, the magnitude of electric force for an insulating liquid is 0.02N.

Worked Example 8.3

Three charges $q_1 = +2 \mu\text{C}$, $q_2 = +3 \mu\text{C}$, and $q_3 = +4 \mu\text{C}$ are placed in air at the vertices of an equilateral triangle of sides 10 cm (see figure). Calculate the magnitude of the resultant force acting on the charge q_3 ?

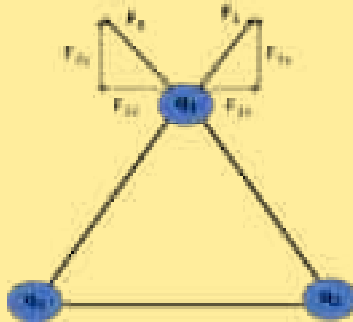
**Solution:**

Step:1 Write down the known quantities and quantities to be found.

$$q_1 = +2 \mu\text{C}, q_2 = +3 \mu\text{C}, q_3 = +4 \mu\text{C}, r = 0.1 \text{ m and } \theta = 60^\circ$$

Magnitude of the resultant force acting on charge $q_3 = F_{\text{resultant}} = ?$

Step:2 Write down the formula and rearrange if necessary.

$$\text{Force between the charge } q_1 \text{ and } q_3 \quad F_1 = k \frac{q_1 q_3}{r^2}$$

$$\text{Force between the charge } q_2 \text{ and } q_3 \quad F_2 = k \frac{q_2 q_3}{r^2}$$

Now, resolving the forces F_1 and F_2 into their components and the resultant value of x and y-components (see figure 8.6)

$$F_x = F_1 \cos \theta - F_2 \cos \theta$$

$$F_y = F_1 \sin \theta + F_2 \sin \theta$$

The magnitude of the resultant force acting.

$$F = \sqrt{F_x^2 + F_y^2} = \sqrt{F_1^2 + F_2^2 + 2F_1 F_2 (\sin^2 \theta - \cos^2 \theta)}$$

Step:3 Put the values in formula and calculate.

To find the force between the charge q_1 and q_3

$$F_1 = 8.988 \times 10^9 \text{ N m}^2/\text{C}^2 \times \frac{2 \times 10^{-6} \text{ C} \times 4 \times 10^{-6} \text{ C}}{(0.1 \text{ m})^2}$$

$$F_1 = 7.2 \text{ N}$$

Similarly, the force between the charge q_2 and q_3

$$F_2 = 8.988 \times 10^9 \text{ N m}^2/\text{C}^2 \times \frac{3 \times 10^{-6} \text{ C} \times 4 \times 10^{-6} \text{ C}}{(0.1 \text{ m})^2}$$

$$F_2 = 10.8 \text{ N}$$

The resultant force.

$$F = \sqrt{(7.2)^2 + (10.8)^2 + 2(7.2)(10.8)\{(\sin 60^\circ)^2 - (\cos 60^\circ)^2\}}$$

$$F = 15.69 \text{ N}$$

Hence, the magnitude of the resultant force acting on the charge q_3 is 15.69 N .

Self-Assessment Questions:

1. Calculate the separation between two electrons (in vacuum) for which the electric force between them is equal to the gravitation force on one of them at the earth surface.
2. If a dielectric medium of dielectric constant ϵ_r is filled in between the charges which are placed at distance r , then show that force between the charges decreases as compare the force when these charge place in air at same distance.

8.2.1 Electric field:

The concept of a field was developed by Michael Faraday (1791–1867) in the context of electric forces.

an electric field is said to exist in the region of space around a charged object. The charged object which produce the electric field is known as the source charge. Michael Faraday also introduced the idea of the electric field lines. These electric lines are imaginary, but these lines can be visualized by the motion of the test charge. The electric field lines around charged objects are very helpful in understanding the field strength and direction of electric field. These field lines are radial and cannot intersect each other. These field lines are originated from a positive charge and terminated on a negative charge as shown in figure 8.5. The electric field is strong where these lines are close together.

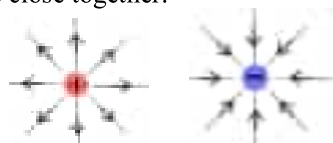

Fig: 8.5

The electric lines of force for positive and negative charge.

Strength of Electric field:

To observe the strength of electric field of the source charge, another charged object is required which is known as the test charge. This test charge experiences the electric force due to the field produced by the source charge.

To be more specific, the electric field \vec{E} at a point in space around the source charge is defined as the electric force F acting on a positive test charge placed at that point divided by the test charge q_0 .

$$\vec{E} = \frac{\vec{F}}{q_0} \quad (8.3)$$

The SI unit of electric field is volts per meter (V/m) or, equivalently, newtons per coulomb (N/C).

DO YOU KNOW?

To eliminate stray electric field interference, circuits of sensitive electronic devices such as T.V and computers are often enclosed with metal boxes.



8.2.2 Electric field of point charge:

To find the electric field due to a charged particle, consider a point charge q as a source charge. This charge creates an electric field at all points in space surrounding it. A test charge q_0 is placed at a distance r from the source charge. (see figure 8.6).



Fig: 8.6

A test charge q_0 in the field of source charge q .

The test charge experiences electric force from which we can determine the direction of the electric field. According to Coulomb's law, the force exerted by q on the test charge is

$$\vec{F} = \frac{1}{4\pi\epsilon_0} \frac{qq_0}{r^2} \hat{r}$$

where \hat{r} is a unit vector directed from q toward q_0 and the direction of force \vec{F} is directly away from the source charge q . To calculate the electric field at a distance r from the point charges, we first calculate the electric field vector using equation 8.3.

$$\vec{E} = \frac{\vec{F}}{q_0} = \frac{1}{4\pi\epsilon_0} \frac{q}{r^2} \hat{r} \quad (8.4)$$

The direction of electric field directly away from the point charge q as shown in **figure 8.9**.

The magnitude of electric field at any given distance r can expressed as:

$$\vec{E} = \frac{1}{4\pi\epsilon_0} \frac{q}{r^2}$$

$$\vec{E} \propto \frac{1}{r^2}$$

This equation shows that the intensity of the electric field decreases with distance from the source charge(s). The field intensity is inversely proportional to the square of the distance from the charge(s).

If there are n number of charged particles $q_1, q_2, q_3, \dots, q_n$, then the net electric force of these charges at a point. According to superposition principle,

$$\vec{F} = \vec{F}_1 + \vec{F}_2 + \vec{F}_3 + \dots + \vec{F}_n$$

From equation 8.6, the net electric field of these charged particles

DO YOU KNOW?

A small positive test charge q_0 placed near a source charge carrying a much greater positive charges q as shown in figure. The test charge is always so small that the field of the source charge is unaffected by its presence.

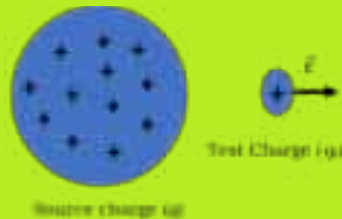

The electric field strength due to the source charge at the location of the test charge is defined as the electric force on the test charge per unit charge.

$$\vec{E} = \frac{\vec{F}_1}{q_0} + \frac{\vec{F}_2}{q_0} + \frac{\vec{F}_3}{q_0} + \dots \dots \frac{\vec{F}_n}{q_0}$$

$$\vec{E} = \vec{E}_1 + \vec{E}_2 + \vec{E}_3 + \dots \dots \vec{E}_n$$

Therefore, the electric fields of these charges experienced by the test charge q_0 is vector sum of electric field of individual charge.

Worked Example 8.4

Find the intensity of electric field at a point such that a proton placed at it would experience a force equal to its weight.

Solution:

Step:1 Write down the known quantities and quantities to be found.

Mass of proton = $m_p = 1.672 \times 10^{-27} \text{ kg}$,

Charge on proton = $q_p = 1.602 \times 10^{-19} \text{ C}$ and $g = 9.8 \text{ m/s}^2$

Step:2 Write down the formula and rearrange if necessary.

$$\vec{E} = \frac{F}{q_p}$$

as the electric force equal to its weight, i.e. $F = W = mg$,

$$\vec{E} = \frac{mg}{q_p}$$

Step:3 Put the values in formula and calculate.

$$\vec{E} = \frac{(1.672 \times 10^{-27} \text{ kg}) \times 9.8 \text{ m/s}^2}{1.602 \times 10^{-19} \text{ C}}$$

$$\vec{E} = 10.22 \times 10^{-8} \text{ N/C}$$

Worked Example 8.5

- Calculate the magnitude of electric field strength, if a test charge $q_0 = +3.5 \mu\text{C}$ experience a force of 70 mN (field lines of electric field shown in figure A).
- if this test charge is replaced by an electron, then calculate force on an electron and state the direction of force.

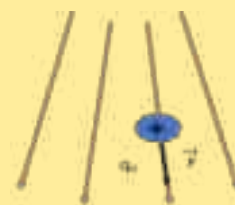

Figure A

Solution:

Step:1 Write down the known quantities and quantities to be found.

$F = 70 \text{ mN} = 70 \times 10^{-3} \text{ N}$, $q_0 = 3.5 \mu\text{C} = 3.5 \times 10^{-6} \text{ C}$

Charge on electron = $q_e = 1.602 \times 10^{-19} \text{ C}$

(a) $E = ?$

(b) $F = ?$

Step:2 Write down the formula and rearrange if necessary.

$$E = \frac{F}{q_0} \text{ and } F = Eq_e$$

Step:3 Put the values in formula and calculate.

$$(a) E = \frac{70 \times 10^{-3} \text{ N}}{3.5 \times 10^{-6} \text{ C}} = 2.0 \times 10^4 \text{ N/C}$$

(b) $F = 2.0 \times 10^4 \text{ N/C} \times 1.602 \times 10^{-19} \text{ C}$
 $F = 3.204 \times 10^{-15} \text{ N}$

The magnitude of the force experienced by an electron is $3,204 \times 10^{-15} \text{ N}$.
 The direction of the force on an electron is directly upwards because field lines is directly downwards and the charge on an electron is negative.

Self-Assessment Question:

A certain gas is filled in a tube and when the electric field reaches to a certain maximum value across the tube then the gas becomes conducting. Explain why the gas becomes conducting.

8.3.1 Electric Dipole:

An electric dipole is a simple system in electromagnetism consisting of two opposite electric charges of equal magnitude, separated by a small distance d as shown in figure. The charges create an electric field that has a distinct pattern, with field lines oriented along the axis of the dipole. The strength and direction of the dipole are represented by its dipole moment. The dipole moment \vec{p} is a vector quantity that represents the strength and direction of the electric dipole. It is defined as the product of the charge magnitude (q) and the distance between the charges d :

$$\vec{p} = q \times d$$

Electric dipoles play a fundamental role in understanding the behavior of polar molecules, interactions in electric fields, and various electrical phenomena in physics and engineering.

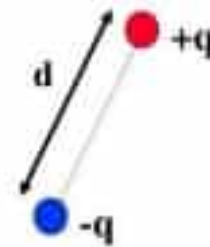

Fig: 8.7

8.3.2 Electric field at point due to two charges:

A pair of equal and opposite point charges separated by a small distance form an electric dipole. To calculate the electric field of the dipole at point C which is at a distance “ y ” from the center of dipole. Consider two charges “ $-q$ ” and “ $+q$ ” place at a small distance “ d ” from each other as shown in figure 8.8. The charge “ $+q$ ” sets up field E_+ and the charge “ $-q$ ” produce the field E_- . (see the figure for the direction of the fields). Resolving the field vectors into the components. From figure, it clear that the vertical components “ $E_+ \cos\theta$ ” and “ $E_- \cos\theta$ ” cancel each other. Therefore, the net electric is due to the vector sum of the horizontal components.

$$\vec{E} = E_+ \cos\theta + E_- \cos\theta$$

The magnitude of both electric fields is the same. From equation (8.4), we have

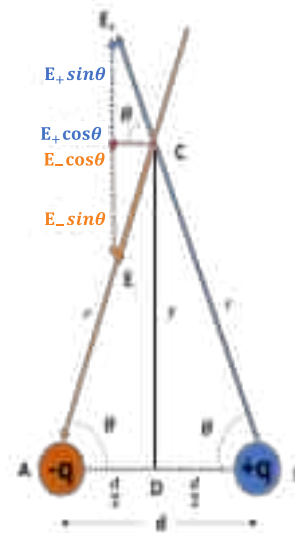

Fig: 8.8
 Electric dipole formed by two charges $+q$ and $-q$.

$$E_+ = E_- = \frac{1}{4\pi\epsilon_0} \frac{q}{r^2}$$

$$E = 2 \times \left(\frac{1}{4\pi\epsilon_0} \frac{q}{r^2} \right) \cos\theta$$

From figure, In triangle ADC,

$$\cos\theta = \frac{d/2}{r} = \frac{d}{2r}$$

Putting the value of $\cos\theta$, we get.

$$E = 2 \times \left(\frac{1}{4\pi\epsilon_0} \frac{q}{r^2} \right) \frac{d}{2r}$$

$$E = \frac{1}{4\pi\epsilon_0} \frac{qd}{r^3}$$

From figure, In triangle ADC,

$$r = \sqrt{y^2 + (d/2)^2}$$

$$E = \frac{1}{4\pi\epsilon_0} \frac{P}{\left(y^2 + (d/2)^2\right)^{3/2}}$$

where the product of the “ q ” and “ d ” is known as the electric dipole moment “ P ” of the dipole. The electric dipole moment is a vector quantity and it is always directed from the negative to the positive charge.

$$E = \frac{1}{4\pi\epsilon_0} \frac{P}{y^3 \left(1 + (d/2y)^2\right)^{3/2}}$$

As $d \ll y$, therefore approximate electric field intensity of the dipole can be calculated by neglecting the term $(d/2y)^2$.

$$E = \frac{1}{4\pi\epsilon_0} \frac{P}{y^3} \quad (8.5)$$

DO YOU KNOW?

Do you know about the electric field lines of two point charges?



Worked example 8.6

Calculate the electric field intensity at point P of two positive charges of same magnitude which are separated by small distance “ d ” as given in figure.

Solution:

Resolving the field vectors into the components. From figure, it clear that the horizontal components cancel each other. Therefore, the net electric is due to the vector sum of the vertical components.

$$E_{total} = E \sin\theta + E \sin\theta$$

$$E_{total} = 2E \sin\theta$$

where $\sin\theta = \frac{y}{r}$ and using equation (8.7), we get

$$E = 2 \times \left(\frac{1}{4\pi\epsilon_0} \frac{q}{r^2} \right) \frac{y}{r}$$

$$E = \frac{1}{2\pi\epsilon_0} \frac{qy}{r^3}$$

where $r = \sqrt{y^2 + (d/2)^2}$

$$E = \frac{1}{2\pi\epsilon_0} \frac{qy}{(y^2 + (d/2)^2)^{3/2}}$$

$$E = \frac{1}{2\pi\epsilon_0} \frac{qy}{y^3 \left(1 + (d/2y)^2 \right)^{3/2}}$$

As $d \ll y$, therefore approximate electric field intensity due to two positive charges can be calculated by neglecting the term $(d/2y)^2$.

$$E = \frac{1}{2\pi\epsilon_0} \frac{q}{y^2}$$

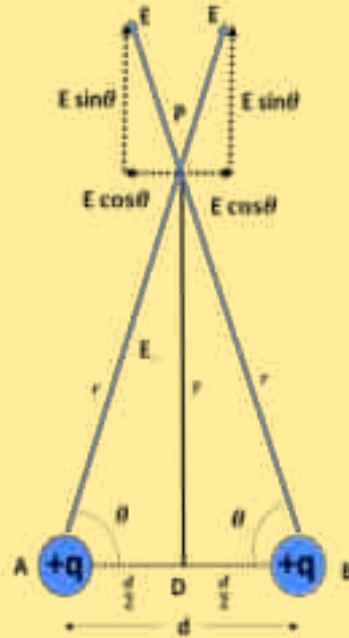
**8.4.1 Electric Flux:**

To understand the electric field lines quantitatively, we consider electric field that is uniform in both magnitude and direction. The field lines penetrate a rectangular surface of area A , whose plane is oriented perpendicular to the field E as shown in **figure 8.9**. The total number of lines penetrating the surface is proportional to the dot product of E and A . Therefore, the dot product of the electric field \vec{E} and vector area \vec{A} is called the electric flux and denoted by Φ_e .

$$\Phi_e = \vec{E} \cdot \vec{A} \quad (8.6)$$

where vector area A is parallel to electric field lines. The SI unit of electric flux is $N \cdot m^2/C$.

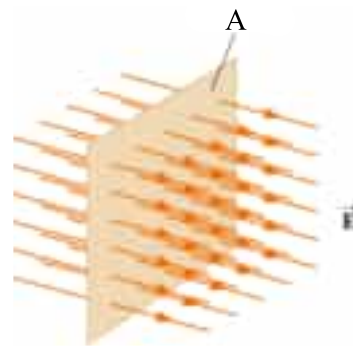

Fig: 8.9
The field lines penetrating through a rectangular surface of area.

If the electric field line penetrating through a surface in such a way that the vector area A is parallel to the field, then the maximum field lines will penetrate through the surface. From above equation,

$$\Phi_e = EA \cos 0^\circ = EA$$

If the electric field line penetrating through a surface in such way that the vector area A is perpendicular to the field, then no field lines will penetrate through the surface.

$$\Phi_e = EA \cos 90^\circ = 0$$

If the electric field line penetrating through a surface in such way that the vector area A is antiparallel to the field, then the electric flux will be negative.

$$\Phi_e = EA \cos 180^\circ = -EA$$

8.4.2 Electric Flux through a surface enclosing a charge:

The definition of electric flux given by equation (8.6) is valid for a small element of area over which the field is approximately constant. To calculate the electric flux through a surface enclosing a charge. This surface is divided into a N number of small elements of area $\Delta A_1, \Delta A_2, \Delta A_3, \dots, \Delta A_N$ as shown in figure 8.10. According to the equation (8.9), the values electric flux through these small area elements are $\vec{E} \cdot \Delta \vec{A}_1, \vec{E} \cdot \Delta \vec{A}_2, \vec{E} \cdot \Delta \vec{A}_3, \dots, \vec{E} \cdot \Delta \vec{A}_N$. Therefore, the net electric flux through the closed surface is given as:

$$\Phi_e = \vec{E} \cdot \Delta \vec{A}_1 + \vec{E} \cdot \Delta \vec{A}_2 + \vec{E} \cdot \Delta \vec{A}_3 + \dots + \vec{E} \cdot \Delta \vec{A}_N$$

$$\Phi_e = \sum_{i=1}^{i=N} \vec{E} \cdot \Delta \vec{A}_N$$

We are often interested to evaluate the flux through a closed surface such as the flux through a surface of a sphere. The electric flux through a sphere can be calculated by considering a sphere of radius “ r ” enclosing the charge “ q ”. If we divide the whole sphere into small area element, then the field lines are penetrating parallel to the vector area for each area element. The area of the sphere is $\sum_{i=1}^{i=N} \Delta A_N = 4\pi r^2$ and electric field at the surface of sphere is $E = \frac{1}{4\pi\epsilon_0} \frac{q}{r^2}$

From equation (8.10), the net electric flux through this sphere is given as

$$\Phi_e = \frac{q}{\epsilon_0}$$

This equation tells us that the net electric flux through a closed surface is equal to $\frac{1}{\epsilon_0}$ time the total charge enclosed in that surface which is known as Gauss’s Law.

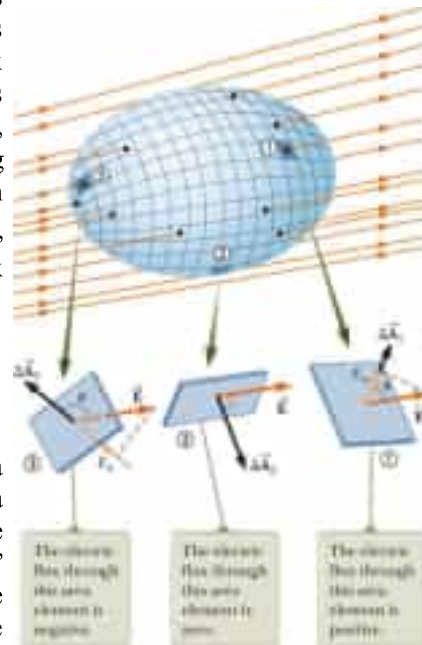

Fig: 8.10
The electric lines of force produced by the source charge enclosed in the closed surface.

Self-Assessment Questions:

1. Sketch the electric field lines for two equal and opposite point charges placed near each other.
2. Calculate the flux of a uniform electric field strength $E = 6\hat{i}N/C$ through surface of vector area $A = (3\hat{i} + 5\hat{j})m^2$.
3. A plane surface is rotated in a uniform electric field. When is the flux of the electric field through the surface maximum? Explain with diagram.

8.5.1 Potential difference:

When a test charge " q_0 " is placed in an electric field " E " created by the source charge then this test charge experiences some force (q_0E). This work is done by some external agent to displace the test charge through a distance " r " from one point to another point against the electric field. This work is stored in form of electric potential energy (U), i.e.,

$$W = U = Fr = q_0Er$$

This situation is analogous to that of lifting an object with mass in a gravitational field: the work done by the external agent is mgh as discussed in Chapter 5. The electric potential is defined as the work done by the test charge to move it from lower potential to the higher potential and given as.

$$V = \frac{W}{q_0} = \frac{U}{q_0} \quad (8.7)$$

Worked Example 8.7

An alpha particle ($+2e$) in a nuclear accelerator moves from one terminal at the potential of $6.5 \times 10^6 V$ to another terminal at zero potential. What is the corresponding change in the potential energy of the system?

Solution:

Step:1 Write down the known quantities and quantities to be found.

Charge on alpha particle $q = 2e = 2 \times 1.6 \times 10^{-19} C$

The electric potential at one terminal $= V_1 = 6.5 \times 10^6 V$

The electric potential at other terminal $= V_2 = 0 V$

$$\Delta U = ?$$

Step:2 Write down the formula and rearrange if necessary.

From equation (8.11), we have $V_1 = \frac{U_1}{q}$, $V_2 = \frac{U_2}{q}$,

Therefore, the change in potential energy

$$\Delta U = q(V_2 - V_1)$$

Step:3 Put the values in formula and calculate.

$$\Delta U = 2 \times 1.6 \times 10^{-19} C (0 - 6.5 \times 10^6 V)$$

Hence, the potential energy of the system is $2.1 \times 10^{-12} J$.

Worked Example 8.8

For what value of change in electric potential to remove the six electrons from the carbon atom if the change in potential energy is 120 keV.

Solution:

Step:1 Write down the known quantities and quantities to be found.

$$q = 6e = 6 \times 1.6 \times 10^{-19} \text{ C}$$

$$\Delta U = 120 \text{ keV} = 120 \times 1.6 \times 10^{-19} \text{ kV}$$

Step:2 Write down the formula and rearrange if necessary.

$$\Delta V = \frac{\Delta U}{q}$$

Step:3 Put the values in formula and calculate.

$$\Delta V = \frac{120 \times 1.6 \times 10^{-19} \text{ kV}}{6 \times 1.6 \times 10^{-19} \text{ C}}$$

$$\Delta V = 20 \text{ kV}$$

Hence, the value of change in electric potential is 20 kV.

8.5.2 Electric Potential of point charge:

The electric potential can be calculated by considering a point charge q as a source charge. This charge creates an electric field at all points in space surrounding it. A test charge q_0 is placed at a distance r from the point charge as shown in figure 8.11. Putting the value of work done ($W = q_0 E r$) in equation (8.7), we get $V = E r$.

Substituting the value of electric field of point charge from equation (8.4), we get

$$V = \frac{1}{4\pi\epsilon_0} \frac{q}{r}$$

Figure 8.16 shows that the potentials at two different places in the field of the charge “ q ”.

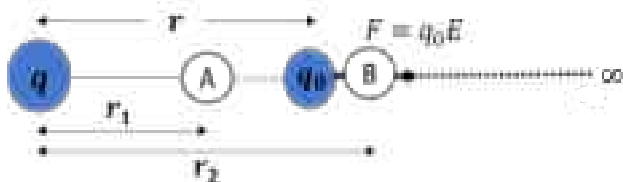

Fig: 8.11: A test charge q_0 in the field of source charge q .

This potential difference can be written as:

$$V_2 - V_1 = \frac{q}{4\pi\epsilon_0} \left(\frac{1}{r_2} - \frac{1}{r_1} \right)$$

where V_1 and V_2 are electric potentials at a distance r_1 and r_2 respectively.

Form above relation, the absolute potential is the work done on a unit charge to bring it from infinity to a certain point in the electric field.

DO YOU KNOW?

This relation can also be used to measure the Hall potential with the help of voltmeter during the Hall Effect experiment.

DO YOU KNOW?

Sharks have special organs that are very sensitive to electric field and can detect potential difference of the order of nano-volt and can locate their prey very precisely.



8.5.3 Calculating electric field from electric potential:

Suppose that a positive test charge q_0 moves through a displacement from one-point A to another point B against the electric field as shown in figure 8.12. The work done in moving the test charge “ q_0 ” through a displacement Δr against the field.

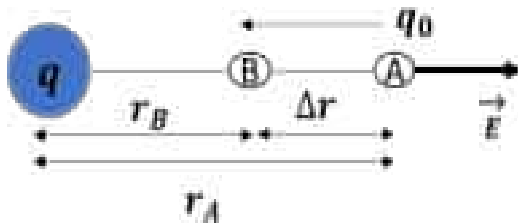

Figure: 8.12: The potentials difference between two points in the electric field.

$$\Delta W = -F\Delta r = -q_0 E \Delta r$$

From the definition of electric potential,

$$\text{we hav } \Delta V = \frac{\Delta W}{q_0} = \frac{-q_0 E \Delta r}{q_0}$$

$$E = -\frac{\Delta V}{\Delta r} \quad (8.8)$$

where $\frac{\Delta V}{\Delta r}$ represent the maximum rate of change of potential with respect to the distance known as potential gradient. Thus, the above equation shows that the electric field intensity can be calculated from the negative potential gradient.

DO YOU KNOW?

A unit of energy commonly used in atomic and nuclear physics is the electron volt (eV), which is defined as the energy a charge-field system gains or losses when a charge of magnitude e is moved through a potential difference of 1 V. The fundamental charge “ e ” is equal to $1.6 \times 10^{-19} \text{ C}$, the electron volt is related to the joule as follows:

$$1 \text{ eV} = 1.6 \times 10^{-19} \text{ C V}$$

$$1 \text{ eV} = 1.6 \times 10^{-19} \text{ C} \left(\frac{\text{J}}{\text{C}} \right)$$

$$1 \text{ eV} = 1.6 \times 10^{-19} \text{ J}$$

Worked Example 8.9

An electron is placed in an xy plane where the electric potential depends on x and y as shown in figure. The scale of the vertical axis is set by one square box equal to 500V. Find the electric field (both cases) acting on the electron between two points as shown in the graph?

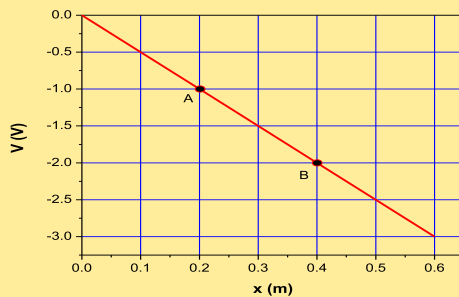

$$\frac{GmM_e}{r_1 r_2} (r_2 - r_1) = GmM_e \left(\frac{r_2 - r_1}{r_1 r_2} \right)$$

Solution:

Step:1 Write down the known quantities and quantities to be found.

From the graph (a) of the given figure

$$\Delta V = -1000 - (-500) = -500 \text{ V}$$

$$\Delta x = 0.4 - 0.2 = 0.2 \text{ m}$$

From the graph (b)

$$\Delta V = 750 - 250 = 500 \text{ V}$$

$$\Delta x = 0.6 - 0.2 = 0.4 \text{ m}$$

Step:2 Write down the formula and rearrange if necessary.

$$E_x = -\frac{\Delta V}{\Delta x} \text{ and } E_y = -\frac{\Delta V}{\Delta y}$$

Step:3 Put the values in formula and calculate.

$$E_x = -\left(\frac{-500 \text{ V}}{0.2 \text{ m}}\right) = 2500 \text{ V/m}$$

Similarly, from the graph (b)

$$E_y = -\frac{\Delta V}{\Delta y} = -\left(\frac{500 \text{ V}}{0.4 \text{ m}}\right) = -1250 \text{ V/m}$$

Hence, the value of electric field acting on the electron in both cases are 2500 V/m and -1250 V/m.

Self-Assessment Questions:

1. Discuss how potential difference and electric field strength are related.
2. If a proton is released from rest in an electric field, will it move in the direction of increasing or decreasing potential? Explain why.



SUMMARY

- The electrostatic force is an attractive or repulsive force between the charged particles. The electric force between stationary charged body is conventionally known as the electrostatic force. It is also referred to as Coulomb's force.
- Coulomb's Law describes the electrostatic force (electric force) between two charged particles. $F = \frac{1}{4\pi\epsilon_0} \frac{q_1q_2}{r^2}$

where $\epsilon_0 = 8.854 \times 10^{-12} \text{ C}^2/\text{N m}^2$ is permittivity of free space. The ratio $\frac{1}{4\pi\epsilon_0}$ is often replaced with Coulomb's constant $k = 8.988 \times 10^9 \text{ N m}^2/\text{C}^2$.

- The **electric field** \vec{E} at some point in space is defined as the electric force \vec{F} that acts on a small positive test charge placed at that point divided by the magnitude q_0 of the test charge. $\vec{E} = \frac{\vec{F}}{q_0}$
- The magnitude of **electric field** set up by a point charge q at a distance r from the charge is,

$$E = \frac{1}{4\pi\epsilon_0} \frac{|q|}{r^2}$$

- An **electric dipole** is a pair of equal and opposite charges $+q$ and $-q$ separated by some distance d . Its dipole moment vector \mathbf{p} has magnitude qd and is in the direction of the dipole axis from $-q$ to $+q$. The magnitude of the electric field set up by the dipole at a distant point perpendicular to the dipole axis is $E = \frac{1}{4\pi\epsilon_0} \frac{p}{y^3}$

- The **electric flux** Φ_e of the electric field \vec{E} through vector area \vec{A} is given by $\Phi_e = \vec{E} \cdot \vec{A}$
- The electric flux through a closed surface is equal to $\frac{1}{\epsilon_0}$ time the total charge enclosed in that surface.
- The **electric potential** is defined as the work done on a charge to move it from lower potential to the higher potential and given as.

$$V = \frac{W}{q_0} = \frac{U}{q_0}$$

- The **electric potential** due to a point charge at any distance r from the charge is

$$V = \frac{1}{4\pi\epsilon_0} \frac{q}{r}$$

- The electric potential associated with a group of point charges is obtained by summing the potentials due to the individual charges.
- The electric field intensity can be calculated from the negative gradient of potential as given below: $E = -\frac{\Delta V}{\Delta r}$
- One electron volt is equivalent to the energy an electron acquires when accelerated across an electric potential difference of one volt. Mathematically, it is represented as:

$$1 \text{ eV} = 1.602 \times 10^{-19} \text{ joules}$$

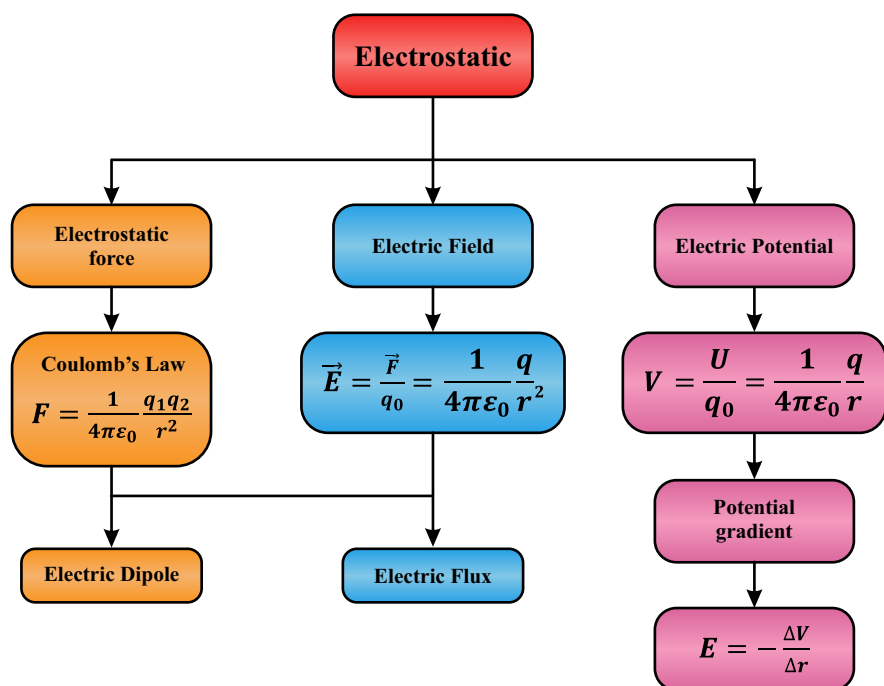



EXERCISE

Section (A): Multiple Choice Questions (MCQs)

- A $2\mu\text{C}$ point charge is located a distance “d” away from $6\mu\text{C}$ point charge, what is the ratio of F_{12}/F_{21} ?
 (a) $1/3$ (b) 3
 (c) 1 (d) 12
- The minimum charge on an object cannot be less than:
 (a) $1.6 \times 10^{-19}\text{C}$ (b) $3.2 \times 10^{-19}\text{C}$
 (c) 9.1×10^9 (d) No definite value exist
- Two charges are placed at a certain distance. If the magnitude of each charge is doubled the force will become
 (a) $1/4$ th of its original value (b) 4 times of its original value
 (c) $1/8$ th of its original value (d) 8 times of its original value
- Which of the following can be deflected while moving in the electric field?
 (a) neutron (b) photon
 (c) electron (d) (a) and (b)
- The flux through a flat surface of area “A” in a uniform electric field “E” is maximum when the surface area is:
 (a) Parallel to E (b) perpendicular to E
 (c) placed 45° to E (d) placed 60° to E
- The product of charge “q” and small separation “d” between two charges of same magnitude and opposite in nature is known as:
 (a) Electric dipole (b) Moment arm
 (c) Electric dipole moment (d) Flux of electric field
- 12 J of work is to be done against an existence electric field to take a charge of 0.01 C from one-point A to another point B. The potential difference between B and A is
 (a) 120 V (b) 1200 V
 (c) 1.2 V (d) 12 V
- The force between two charges placed in air is F. if air is replaced by a medium of relative permittivity ϵ_r then force is reduced to:
 (a) $F\epsilon_r$ (b) F/ϵ_r
 (c) ϵ_r/F (d) $\epsilon\epsilon_r$
- The negative gradient of the potential is:
 (a) potential energy (b) voltage
 (c) electric field intensity (d) electric flux
- The electric flux through a plane area will be half of its maximum value when area is held at angle of _____ with electric field
 (a) 30° (b) 60°
 (c) 45° (d) 90°

Section (B): Structured Questions

CRQs:

1. Why do most objects tend to contain nearly equal numbers of positive and negative charges?
2. When measuring an electric field, could we use a negative rather than a positive test charge?
3. During fair weather, the electric field due to the net charge on Earth points downward. Is Earth charged positively or negatively?
4. How the electric flux through a closed surface is independent on the size or shape of the surface enclosed the charge.
5. What is electric dipole and electric dipole moment?
6. A charged particle is seen to be moving in an electric field along a straight line. How it effects the path of motion of the particle?
7. An electron has a speed of 10^6 m/s. Find its energy in electron volt. **(Ans. 2.84 eV)**

ERQs:

1. Define electric charge. Discuss the fundamental properties of electric charge, including the principles of conservation of charge and quantization of charge.
2. State and explain Coulombs law. Apply it to calculate the electric field due to an isolated point charge.
3. Define electric flux and explain its significance in the study of electromagnetism. How does it relate to electric fields and charged particles?
4. What is electric potential? Derive expression for potential due to an isolated point charge.
5. Define an electric dipole. Derive formula for the electric field due to an electric dipole at a point "P" placed on its axial line.

Numericals:

1. (a) Calculate the value of two equal charges if they repel one another with a force of 0.1 N when situated 50 cm apart in a vacuum.
(b) What would be the size of the charges if they were situated in an insulating liquid whose permittivity was ten times that of a vacuum? **(Ans. $1.7 \mu\text{C}$, $5.3 \mu\text{C}$)**
2. How far apart must two protons be if the magnitude of the electrostatic force acting on either one due to the other is equal to the magnitude of the gravitational force on a proton at Earth's surface? (mass of proton = 1.67×10^{-27} kg, charge of proton = 1.6×10^{-19} C) **(Ans. 0.119 m)**
3. An electron of charge 1.6×10^{-19} C is situated in a uniform electric field of intensity 1200-volt cm^{-1} . Find the force on it, its acceleration, and the time it takes to travel 2 cm from rest (electronic mass, $m_e = 9.1 \times 10^{-31}$ kg).
(Ans. 1.92×10^{-14} N, $2.12 \times 10^{16} \text{ms}^{-2}$, 1.37×10^{-9} s).

4. An alpha particle (the nucleus of a helium atom) has a mass of 6.64×10^{-27} kg and a charge of $2e$. What are the (a) magnitude and (b) direction of the electric field that will balance the gravitational force on the particle?

(Ans. 2.03×10^{-7} N/C, the electric field is directed upwards)

5. A proton and an electron form two corners of an equilateral triangle of side length 2.0×10^{-6} m. What is the magnitude of the net electric field these two particles produce at the third corner? (Ans. 3.6×10^2 N/C)

6. Figure shows two charged particles on an x axis: $-q = -3.20 \times 10^{-19}$ C at $x = -3.00$ m and $q = 3.20 \times 10^{-19}$ C at $x = 3.00$ m. What are the (a) magnitude and (b) direction (relative to the positive direction of the x axis) of the net electric field produced at point P at $y = 4.00$ m?

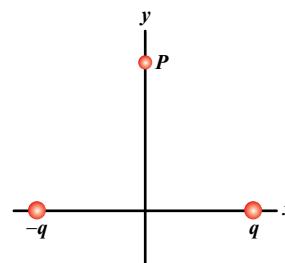

(Ans. 1.38×10^{-10} N/C, The net electric field points in the $-x$ direction)

7. A proton and an electron form two corners of an equilateral triangle of side length $5 \mu\text{m}$. What is the magnitude of the net electric field these two particles produce at the third corner?

8. The square surface shown in figure measures 3.2 mm on each side. It is immersed in a uniform electric field with magnitude $E = 1800$ N/C and with field lines at an angle of $\theta = 35^\circ$ with a normal to the surface, as shown. Take that normal to be directed “outward,” as though the surface were one face of a box. Calculate the electric flux through the surface. (Ans. -1.5×10^{-2} N.m²/C)

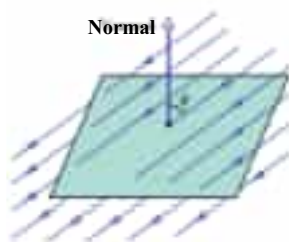

9. An electron is liberated from the lower of two large parallel metal plates separated by a distance $h = 2$ cm. The upper plate has a potential of 2400 volts relative to the lower. How long does the electron take to reach it? (Ans. 1.2×10^5 Vm⁻¹)

10. Two large parallel metal plates are 1.5 cm apart and have charges of equal magnitudes but opposite signs on their facing surfaces. Take the potential of the negative plate to be zero. If the potential halfway between the plates is then 5.0 V, what is the electric field in the region between the plates? (Ans. 6.7×10^2 V/m)



Various types of Capacitors

In this unit student should be able to:

- Explain capacitors as Charge storing Devices.
- Identify types of capacitors used in different field.
- Identify factors affecting the capacitance of a parallel plate capacitor and use equations
 $\epsilon_r = C/C_0$; $C = \epsilon_0 \epsilon_r A/d$.
- Calculate combined capacitance of capacitors in series and in parallel.
- Demonstrate charging and discharging of a capacitor through a resistance.
- Prove that energy stored in capacitor is:
 $W = \frac{1}{2} QV$ and hence $E = \frac{1}{2} CV^2$

9.1.1 Capacitor:

A capacitor is an electrical device which is used to store electrical energy in the same way as the bucket is used for storing water or a tank for storing gas. Each of these devices has fixed capacity which does not depend on the quantity to be stored.

Capacitors are electronic components designed to store electric charge. Figure 9.1 shows the schematic diagram of parallel plate capacitors. They consist of two conductive plates separated by an insulating material called a dielectric. When a voltage is applied across the plates, one plate accumulates a positive charge while the other accumulates an equal and opposite negative charge, resulting in the storage of electric charge in the capacitor.

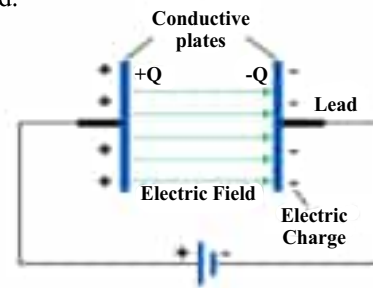

Fig: 9.1
A Parallel Plate Capacitor.

The ability of a capacitor to store charge is determined by its capacitance (C), which is measured in farads (F). The capacitance depends on the physical characteristics of the capacitor, such as the area of the plates, the distance between them, and the properties of the dielectric material.

The quantity of charge Q on a capacitor is directly proportional to the potential difference V between the plates; that is, $Q \propto V$.

$$Q = CV \quad (9.1)$$

Where:

Q = Electric charge stored in the capacitor (measured in coulombs, C)

C = Capacitance of the capacitor (measured in farads, F)

V = Voltage applied across the capacitor (measured in volts, V)

The proportionality constant depends on the shape and separation of Plates.

The capacitance of a capacitor is defined as

“The amount of charge required to create a unit potential difference between Parallel plates.”

From equation (9.1), the capacitance C of a capacitor can be measured as

$$C = \frac{Q}{V}$$

Hence, capacitance is the charge stored per unit potential difference.

DO YOU KNOW?

Capacitors are very useful to reduce voltage fluctuations in electronic power supplies, to transmit signals, to detect electro-magnetic oscillations at radio frequencies and to other important electronic circuits.

DO YOU KNOW?



Capacitor also used as sensor

9.1.2 Types of Capacitor:

Capacitors play a very important role in various electrical circuits, especially radio circuit. Here we classify some common types of capacitors.

Variable Capacitors:

This type of capacitor is used to control the capacitance continuously for tuning transmitters and receivers signals.



Variable capacitor

Film Capacitors:

Film Capacitors consisting of a relatively large family of capacitors with the difference being in their dielectric properties. They are available in almost any value and voltages as high as 1500 volts. Film capacitors are used in power electronics devices, phase shifters, X-ray flashes and pulsed lasers.



Film capacitor

Ceramic capacitors:

These capacitors are used in high-frequency circuits ranging from audio to radio frequency. These capacitors are also called disc capacitors.



Ceramic capacitor

Electrolytic Capacitors:

These capacitors are generally used when very large capacitance values are required. The majority of electrolytic capacitors are polarized. Electrolytic Capacitors are generally used in DC power supply circuits due to their large capacitance's and small size which help to reduce the ripple voltage.



Electrolytic capacitor

9.1.3 Capacitance of a parallel plate Capacitor:

It consist of two parallel metallic plates of equal area A which are separated by a distance d as shown in **figure 9.2**. Both parallel plates carry charges of magnitude $+Q$ and $-Q$ respectively. The surface charge density (σ) is defined as the charge stored (Q) per unit area (A).

$$\sigma = Q / A$$

Therefore, the electric field in this case will be

$$E = \frac{Q}{A\epsilon_0} = \frac{\sigma}{\epsilon_0} \dots \dots (9.2)$$

As the field between the plates is uniform, therefore, the magnitude of the potential difference between the plates equals Ed . i.e., $V=Ed$, Substituting the value of V from equation (9.1), we get,

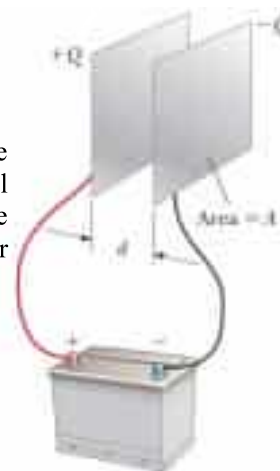

Fig: 9.2

A parallel-plate capacitor consists of two parallel conducting plates, each of area A , separated by a distance d .

$$E = \frac{V}{d} = \frac{Q}{Cd} \quad \dots \dots (9.3)$$

By comparing the equations (9.2) and (9.3), we get relation for capacitance as given below

$$C = \frac{\epsilon_0 A}{d} \quad \dots \dots (9.4)$$

Equation (9.4) shows that the capacitance of a parallel-plate capacitor is proportional to the area of plates and inversely proportional to the plate separation.

Effects of dielectric materials:

Experimentally it is found that capacitance of a capacitor can be increased by filling the space between the plates with dielectrics. Dielectrics are electrically insulating materials that increase the ability of storing charges on the plates of the capacitor. Polythene and waxed paper are the examples of dielectrics.

Microscopically, the molecules of the dielectric materials become polarized by the charged plates of the capacitor as shown in figure 9.3. This polarization is responsible to increase the capacitance of the capacitor. When the dielectric is inserted between the plates of a capacitor, then permittivity of such capacitor will increase by the amount of $\epsilon_0 \epsilon_r$. where ϵ_r is the relative permittivity of a substance and it is called the dielectric constant.

Therefore, the capacitance of such capacitor is given as

$$C_o = \frac{\epsilon_0 \epsilon_r A}{d}$$

$$C_o = \epsilon_r \left(\frac{\epsilon_0 A}{d} \right) = \epsilon_r C$$

The above relation shows that the charge storing capacity of a capacitor is enhanced by the dielectric which permits it to store ϵ_r times more charge for the same potential difference.

$$\epsilon_r = \frac{C_o}{C} \quad \dots \dots (9.5)$$

The relative permittivity ϵ_r of the material is the ratio of the capacitance of a capacitor with a given materials filling the space between the plates to the capacitance of the same capacitor when space is evacuated. Typical values of ϵ_r are presented in table 9.1.

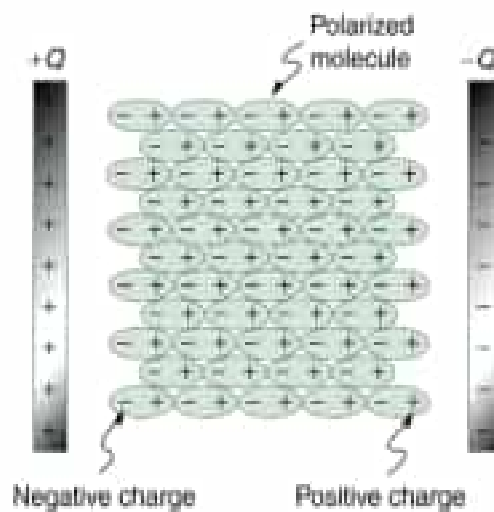

Fig: 9.3
A capacitor filled with dielectric material.

Table No. 9.1: Dielectric Constant (ϵ_r)

S/No.	Insulating material	Dielectric constant
1	Vacuum	1
2	Air	1.0006
3	Teflon	2
4	Mineral Oil	2.2
5	Polyethylene	2.3
6	Waxed paper	2.5
7	Epoxy	3.3
8	PVC	3.7
9	Nylon	4.1
10	Bakelite	5
11	Mica	7
12	Water	81

Worked Example 9.1

A parallel plate capacitor consists of two plates with an area of 0.01 m^2 each, separated by a distance of 0.002 m . The capacitor is filled with a dielectric material having a relative permittivity (ϵ_r) of 4. Calculate the capacitance of this capacitor.

Solution:

Step 1: Formula:

$$C = \epsilon_0 \epsilon_r A / d$$

where:

C is the capacitance,

ϵ_0 is the vacuum permittivity constant (approximately $8.854 \times 10^{-12} \text{ F/m}$),

ϵ_r is the relative permittivity (given as 4),

A is the area of one plate (0.01 m^2),

d is the separation distance between the plates (0.002 m).

Step 2:

Now, substitute the given values into the formula:

$$C = (8.854 \times 10^{-12} \text{ F/m}) \times 4 \times (0.01 \text{ m}^2) / (0.002 \text{ m})$$

$$C \approx 8.854 \times 10^{-12} \times 4 \times (0.01 / 0.002) \text{ F}$$

$$C \approx 3.5416 \times 10^{-11} \text{ F}$$

So, the capacitance of the parallel plate capacitor is approximately 3.5416×10^{-11} Farads (F).

Self-Assessment Questions:

1. The capacitance of a capacitor formed by two parallel metal plates each 200 cm² in area separated by a dielectric 4 mm thick is 0.0004 microfarads. A potential difference of 20,000 V is applied. Calculate the total charge on the plates?

9.1.4 Combinations of Capacitors:

Two or more capacitors often are combined in electric circuits. We can calculate the equivalent capacitance of certain combinations with the help of a circuit diagram. The circuit symbols for capacitors, batteries, and switches are shown in figure 9.4.

Parallel Combination of capacitors:

In a parallel combination of capacitors, two or more capacitors are connected side by side with their positive terminals connected together and their negative terminals connected together. This arrangement allows the capacitors to share the same voltage across their terminals while increasing the total capacitance of the combination.

When capacitors are connected in parallel, the total capacitance (C_{total}) of the combination is the sum of the individual capacitances ($C_1, C_2, C_3,$ and so on) of the capacitors connected:

$$C_{total} = C_1 + C_2 + C_3 + \dots + C_n$$

Consider three capacitors are connected in parallel combination as shown figure 9.5 and all three diagrams are equivalent. we know that potential difference across each capacitors connected in parallel are the same and equal to the potential difference applied across the combination. i.e.,

$$V = V_1 = V_2 = V_3$$

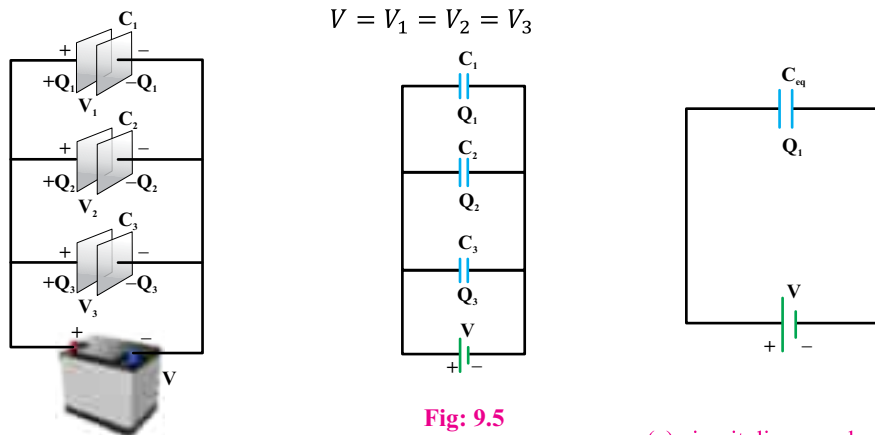

(a) a pictorial representation of three capacitors connected in parallel to a battery

(b) circuit diagram showing the three capacitors connected in parallel to a battery

(c) circuit diagram showing the equivalent capacitance of the capacitors connected in parallel.

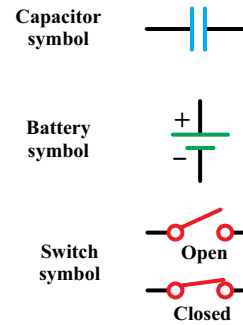

Fig: 9.4
Circuit symbols for capacitors, batteries, and switches.

Unit 9: Capacitors

In general, when a potential difference V is applied across several capacitors connected in parallel, that potential difference V is same across each capacitor. The total charge Q stored on the equivalent capacitor is the sum of the charges stored on all the capacitors.

To find an expression for equivalent capacitance C_{eq} , use the eq. (9.1) to find the charge on each actual capacitor and equivalent capacitor.

$$Q_1 = C_1V, \quad Q_2 = C_2V, \quad Q_3 = C_3V \quad \text{and} \quad Q = C_{eq}V$$

The total charge on the parallel combination is given as

$$\begin{aligned} Q &= Q_1 + Q_2 + Q_3 \\ C_{eq}V &= C_1V + C_2V + C_3V \\ C_{eq} &= C_1 + C_2 + C_3 \quad \dots (9.6) \end{aligned}$$

Therefore, the equivalent capacitance of a parallel combination of capacitors is the algebraic sum of the individual capacitances and has greater value than any of the individual capacitances. This combination is used in the circuit where the high capacitance is required because equivalent capacitor store more energy.

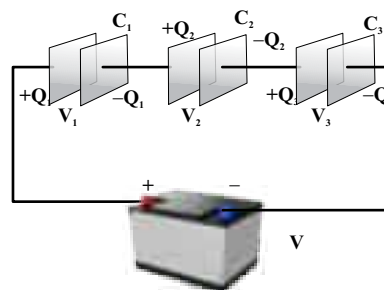

(a)

Series Combination of capacitors:

In a series combination of capacitors, two or more capacitors are connected one after the other in a single line, with the positive terminal of one capacitor connected to the negative terminal of the next capacitor. This arrangement allows the capacitors to share the same charge while effectively reducing the total capacitance of the combination compared to individual capacitors.

Three capacitors are connected in series combination as shown Figure 9.6 (a, b, c) and all three diagrams are equivalent. In series means that the capacitors are connected by a wire and there is no other way of flowing of charge. When a potential V is applied across them, the same amount Q of charge will appear on each of the capacitor. The battery directly produces charges on only the two plates to which it is connected. Charges that are produced on the other plates are due to the simple impact of electric field induction. Due to this the charges can be distributed over all other plates connected in the circuit. Therefore, the charges on capacitors connected in series are the same.

In general, the total potential difference across any number of capacitors connected in series is the sum of the potential differences across the individual capacitors.

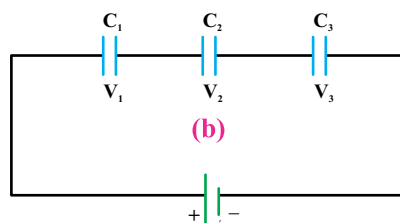

(b)

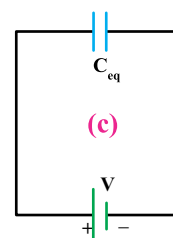

(c)

Fig: 9.6

- (a) a pictorial representation of two capacitors connected in series to a battery
- (b) circuit diagram showing the two capacitors connected in series to a battery
- (c) circuit diagram showing the equivalent capacitance of the capacitors connected in series

$$V = V_1 + V_2 + V_3$$

To find an expression for equivalent capacitance C_{eq} , use the eq. (9.1) to find the potential difference across each actual capacitor and equivalent capacitor.

$$V_1 = \frac{Q}{C_1}, V_2 = \frac{Q}{C_2}, V_3 = \frac{Q}{C_3} \text{ and } V = \frac{Q}{C_{eq}}, \text{ therefore,}$$

we have

$$\frac{Q}{C_{eq}} = \frac{Q}{C_1} + \frac{Q}{C_2} + \frac{Q}{C_3}$$

$$\frac{1}{C_{eq}} = \frac{1}{C_1} + \frac{1}{C_2} + \frac{1}{C_3} \quad \dots \dots (9.7)$$

This expression shows that the reciprocal of the equivalent capacitance is the algebraic sum of the reciprocal of the individual capacitance. Thus, the equivalent capacitance of a series combination is always less than any individual capacitance.

Self-Assessment Questions:

1. Find the equivalent capacitance of the circuit shown in figure and all capacitors have the same capacitance of $15\mu F$.

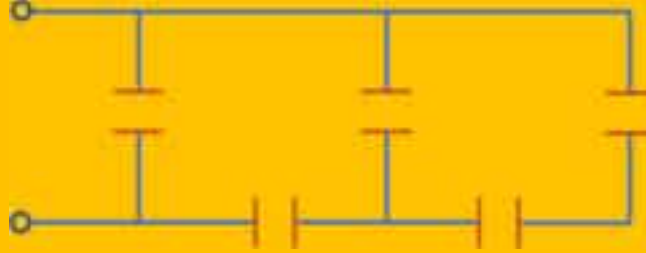

2. Two capacitors X and Y are connected in series across a 100 V supply and it is observed that the potential difference across them are 60 V and 40 V respectively. A capacitor of $2\mu F$ capacitance is now connected in parallel with X and the potential difference across Y rises to 90 volts. Calculate the capacitance of X and Y.

9.2.1 Charging and discharging of a capacitor through a resistor:

Consider a circuit having a capacitance C and a resistance R which are connected in series with a battery of potential difference V through a switch as shown in the **figure 9.7**. This circuit is called RC circuit.

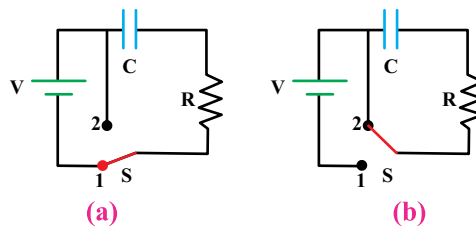

Fig: 9.7 Resistor Capacitor (RC) circuit.

When the switch is at position 1 as shown in Fig. 9.7(a), the capacitor begins to store charge. If at any time during charging, the charge Q flowing through the circuit and Q is the charge on the capacitor, then sum of potential difference between the plates of the capacitor and across the resistor is equal to the potential difference supply from the battery. As the current stops flowing when the capacitor is fully charged, When $Q = Q_0$ (the maximum value of the charge on the capacitor), then

$$Q_0 = C V$$

Experiments shows that the charging process of a capacitor exhibits the exponential behaviour therefore we can write its equation as

$$Q = Q_0(1 - e^{-t/R}) \quad \dots \dots (9.8)$$

where Q_0 represents the final charge on the capacitor that accumulates. Where the quantity $\tau = RC$ is called the time constant or the capacitive time constant of the circuit and it has dimensions of time. Further,

if $RC \ll 1$, Q will attain its final value rapidly
if $RC \gg 1$, it will do so slowly.

Thus, RC determines the rate at which the capacitor charges (or discharges) itself through a resistance.

If $\tau = t$, the from equation (9.8)

$$Q = Q_0(1 - e^{-1}) = Q_0 \left(1 - \frac{1}{e}\right)$$

$$Q = Q_0 \left(1 - \frac{1}{2.718}\right) = Q_0(1 - 0.368)$$

$$Q = 0.632Q_0 \dots \dots (9.9)$$

Therefore the time constant is the duration of time for the capacitor in which 63.2% of its maximum value charge is deposited on the plates during the charging of the capacitor. The equation (9.8) shows that charge builds up exponentially during the charging process (See Fig. 9.8 a).

When the switch is moved to position 2, for the circuit which shows the discharging of the charged capacitor (see Fig. 9.8(b). The battery is now out of the circuit and the capacitor will discharge itself through resistor R . This discharging process of the capacitor follows the following equation.

$$Q = Q_0 e^{-t/\tau} \quad (9.10)$$

where Q_0 represents the initial charge on the capacitor at the beginning of the discharge, i.e., at $t=0$. The above expression shows that the charge

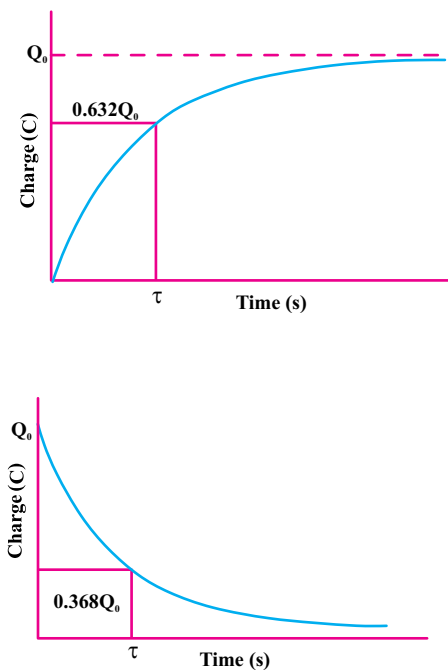

Fig: 9.8
Capacitor (a) charging and (b) discharging verses time.

decays exponentially when the capacitor discharges, and that it takes an infinite amount of time to fully discharge.

If $\tau = RC = t$, the equation (9.9) becomes

$$Q = Q_0 e^{-1} = \frac{Q_0}{e} = \frac{Q_0}{2.718}$$

$$Q = 0.368 Q_0 \dots\dots(9.11)$$

Time constant of a RC circuit is thus also the time during which the charge on the capacitor falls from its maximum value to 0.368 of its maximum value.

9.2.2 Energy Stored in a Capacitor:

Charging of a capacitor always involves some expenditure of energy by the charging agency. This energy is stored up in the electrostatic field set up in the dielectric medium. On discharging the capacitor, the field collapses and the stored energy is released. Many of those who work with electronic equipment have at some time verified that a capacitor can store energy. If the plates of a charged capacitor are connected by a conductor such as a wire, charge moves between each plate and its connecting wire until the capacitor is uncharged.

The discharge can often be observed as a visible spark. If you accidentally touch the opposite plates of a charged capacitor, your fingers act as a pathway for discharge and the result is an electric shock. The degree of shock you receive depends on the capacitance and the voltage applied to the capacitor. Such a shock could be dangerous if high voltages are present as in the power supply of a home theater system. Because the charges can be stored in a capacitor even when the system is turned off, unplugging the system does not make it safe to open the case and touch the components inside.

Let us consider a capacitor connected to source of potential difference V . Initially, when the capacitor is uncharged, the potential difference between the plates is zero. Finally when charge $+Q$ and $-Q$ deposited on the plates, the potential difference between the plates becomes V . The average voltage on the capacitor during the charging process is $V/2$. See unit 08 section 8.5.2, The equation (8.7) can be modified for this case

$$\frac{V}{2} = \frac{U}{Q}$$

$$U = \frac{1}{2} QV \quad \therefore Q = CV$$

DO YOU KNOW?

The flash which comes from the camera when we take photographs is due to the energy released from the capacitor.



DO YOU KNOW?

During cardiac arrest, heart defibrillator is used to give a sudden surge of a large amount of electrical energy to the patient's chest to retrieve the normal heart function.



$$U = \frac{1}{2} CV^2 \quad \dots \dots (9.12)$$

For a given capacitance, the stored energy increases as the charge and the potential difference increase. In practice, there is a limit to the maximum energy (or charge) that can be stored because, at a sufficiently large value of V, discharge ultimately occurs between the plates. For this reason, capacitors are usually labeled with a maximum operating voltage.

Self-Assessment Questions:

1. A 2200 μF capacitor is charged to a potential difference of 9.0 V then discharged through a 100 k Ω resistor. Calculate (a) the initial charge stored by the capacitor, (b) the time constant of the circuit, (c) calculate the potential difference after a time of 300s equal to the time constant.
2. An air-capacitor of capacitance 0.005 μF is connected to a direct voltage of 500 V, is disconnected and then immersed in oil with a relative permittivity of 2.5. Find the energy stored in the capacitor before and after immersion.



SUMMARY

- A capacitor consists of two isolated plates with charges +q and -q. Its capacitance C is defined from $Q = CV$
- where V is the potential difference between the plates. The capacitance depends only on the geometry of the conductors and not on an external source of charge or potential difference. The SI unit of capacitance is coulombs per volt, or the farad (F): 1 F = 1 C/V.
- A parallel-plate capacitor with flat parallel plates of area A and spacing d has capacitance $C = \frac{\epsilon_0 A}{d}$
- If the space between the plates of a capacitor is completely filled with a dielectric material, the capacitance C is increased by a factor ϵ_r , called the dielectric constant, which is characteristic of the material. In a region that is completely filled by a dielectric, all electrostatic equations containing ϵ_0 must be modified by replacing ϵ_0 with $\epsilon_0 \epsilon_r$.
- The effects of adding a dielectric can be understood physically in terms of the action of an electric field on the permanent or induced electric dipoles in the dielectric slab. The result is the formation of induced charges on the surfaces of the dielectric, which results in a weakening of the field within the dielectric for a given amount of free charge on the plates.
- If two or more capacitors are connected in parallel, the potential difference is the same across all capacitors. The equivalent capacitance of a parallel combination of capacitors is
 $C_{\text{eq}} = C_1 + C_2 + C_3 + \dots$
- If two or more capacitors are connected in series, the charge is the same on all capacitors, and the equivalent capacitance of the series combination is given by

- $1/C_{eq} = 1/C_1 + 1/C_2 + 1/C_3 + \dots$
- Experiments shows that the charging process of a capacitor exhibits the exponential behaviour therefore we can write its equation as

$$Q = Q_0(1 - e^{-t/RC}) \quad (9.8)$$
 - where as The discharging process of the capacitor follows the following equation.

$$Q = Q_0e^{-t/\tau} \quad (9.9)$$
 - where the quantity $\tau = RC$ is called the time constant or the capacitive time constant of the circuit.
 - Energy is stored in a charged capacitor because the charging process is equivalent to the transfer of charges from one conductor at a lower electric potential to another conductor at a higher potential. The energy stored in a capacitor of capacitance C with charge Q and potential difference V is

$$U = \frac{1}{2}QV = \frac{1}{2}CV^2$$

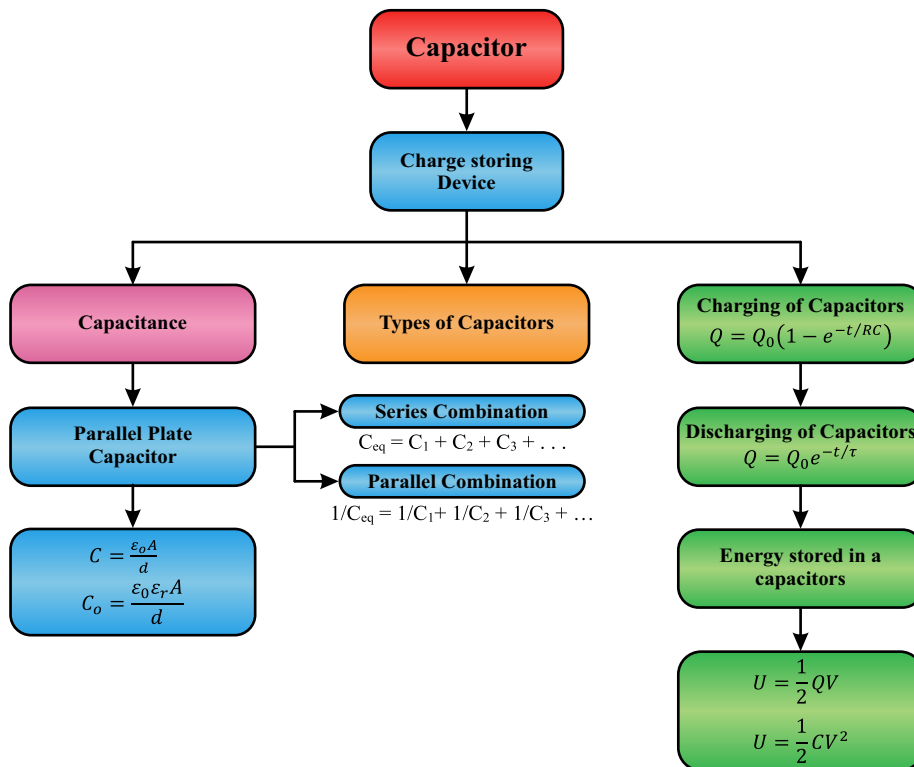



EXERCISE

Section (A): Multiple Choice Questions (MCQs)

- The capacitance of a capacitor is NOT influenced by:
(a) Plate thickness (b) Plate area
(c) Plate separation (d) Nature of the dielectric
- What is the value of capacitance of a capacitor which has a voltage of 4V and has 16C of charge?
(a) 2F (b) 4F (c) 6F (d) 8F
- Capacitors are used in electric power supply system to:
(a) Improve power factor (b) Reduce line current
(c) Provide voltage stability (d) switching
- In a variable capacitor, capacitance can be varied by:
(a) Turning the rotatable plates in or out (b) Changing the plates
(c) Sliding the rotatable plates (d) Changing the material of plates
- Energy stored in the capacitor is:
(a) $E = \frac{1}{4} CV$ (b) $E = \frac{1}{2} CV^2$ (c) $E = CV^2$ (d) $E = \frac{1}{2} CV$
- The time constant of a series RC circuit consisting of $100\mu F$ capacitor in series with a 100Ω resistor is:
(a) 0.1 s (b) 0.1 ms (c) 0.01 s (d) 0.01 ms
- The charging of a capacitor through a resistance follows:
(a) linear law (b) square law
(c) exponential law (d) none of the above
- When the total charge in a capacitor is doubled, the energy stored
(a) remains the same (b) is doubled
(c) is halved (d) is quadrupled
- The capacitance C is charged through a resistor R. The time constant of the charging circuit is given by:
(a) C/R (b) 1/RC (c) RC (d) R/C
- Capacitor blocks:
(a) alternating current (b) direct current
(c) both alternating and direct current (d) neither alternating nor direct current

Section (B): Structured Questions

CRQs:

- State the factors on which the capacitance of a parallel plate capacitor depends.
- Explain what is meant by dielectric constant (relative permittivity). State two physical properties desirable in a material to be used as the dielectric in a capacitor.
- Derive expressions for the combined capacitance of two capacitors (a) connected in series, (b) connected in parallel.

- Derive an expression for the energy stored in a capacitor C when there is a potential difference V between the plates.
- A capacitor gets a charge of 50C when it is connected to a battery of emf 5 V . Calculate the capacity of the capacitor.

ERQs:

- Calculate combined capacitance of capacitors in series and in parallel.
- Prove that energy stored in a capacitor is $E = \frac{1}{2}CV^2$
- Describe the factors affecting the capacitance of a parallel plate capacitor?

Numericals:

- The capacitance of air-filled parallel-plate capacitor is 1.3 pF . If the separation of the plates is doubled and wax is inserted between them. The new capacitance is 2.6 pF . Find the dielectric constant of the wax. **(Ans. 4.0)**
- Three capacitors have capacitances $10, 50$ and $25\ \mu\text{F}$ respectively as shown in figure. Calculate (i) charge on each when connected in parallel to a 250 V supply (ii) total capacitance and (iii) potential difference across each when connected in series. **(Ans.(i) $2.5\text{ mC}, 12.5\text{ mC}, 6.75\text{ mC}$ (ii) $85\ \mu\text{F}$ (iii) $156.25\text{ V}, 62.5\text{ V}, 31.25\text{ V}$)**
- Three capacitors are connected through a potential difference of 100 volts as shown in figure. Find the charges and potential difference across each capacitor. **(Ans. $160\ \mu\text{C}, 60\ \mu\text{C}, 100\ \mu\text{C}, V_1=80\text{ V}, V_2=20\text{ V}$)**
- Capacitor is charged through a large non-reactive resistance by a battery of constant voltage V . For this arrangement, if the capacitor has a capacitance of $10\ \mu\text{F}$ and the resistance is $1\text{ M}\ \Omega$, calculate the time taken for the capacitor to receive 90% of its final charge. **(Ans. 23s)**
- What capacitance is required to store energy of 10 kWh at a potential difference of 1000 V ? **(Ans. 72 F)**
- A $2.0\ \mu\text{F}$ capacitor and a $4.0\ \mu\text{F}$ capacitor are connected in parallel across a 300 V potential difference. Calculate the total energy stored in the capacitors. **(Ans. 0.27J)**
- A 12.0-V battery is connected to a capacitor, resulting in $54.0\ \mu\text{C}$ of charge stored on the capacitor. How much energy is stored in the capacitor?
(Ans. $3.24 \times 10^{-4}\text{J}$)

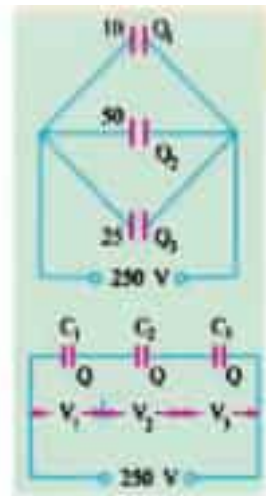

Figure for 9.9

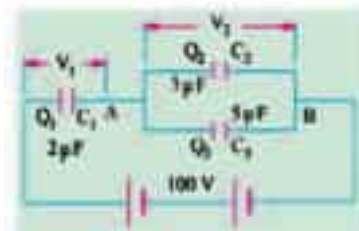

Figure for 9.10



In this unit student should be able to:

- Recall the concept of resistance.
- Indicate the value of resistance by reading color code on it.
- Define the resistivity and explain its dependence upon temperature and also derive the mathematical relationship between them.
- Solve problems using the equation of resistivity.
- Understand the effects of the internal resistance of e.m.f on the terminal potential difference.
- Distinguish between e.m.f and p.d. using the energy consideration.
- Explain the internal resistance of sources and its consequences for external circuits.
- Describe some sources of e.m.f.
- Describe the conditions for maximum power transfer.
- Describe thermocouple and its functions.
- Explain variation of thermoelectric e.m.f. with temperature.
- Identify the function of thermistor in fire alarms and thermostats that control temperature.
- State Kirchhoff's first law and appropriate the link to conservation of charge.
- State Kirchhoff's second law and appropriate the link to conservation of energy.
- Derive the equation by using Kirchhoff's laws, a formula for the combined resistance of two or more resistors connected in series and parallel.
- Describe the Wheatstone bridge and how it is used to find unknown resistance.
- Describe the working of rheostat as a potential divider in circuit.
- Describe the function of potentiometer to measure and compare potentials without drawing any current from it.

10.1 Resistors:

In electronic circuits resistors usually serve two main purposes to

1. Limit the current flow to a specified value
2. Provide a desired reduction in voltage, or current.

Resistance is a measure of the opposition to current flow in an electrical circuit.

Suppose we maintain a potential difference across the ends of a conductor. How does the current *I* that flows through the conductor depend on the potential difference ΔV . For many conductors, the current is proportional to the potential difference.

George Simon Ohm (1789-1854) first observed this relationship, which is now called **Ohm's law**:

According to Ohm's law:

$$\Delta V = IR$$

$$I = \Delta V / R$$

Hence the electrical resistance **R** is defined to be the ratio of the potential difference for voltage ΔV across a conductor to the current **I** through the material

$$R = \Delta V / I \quad \dots(10.1)$$

In SI units, electrical resistance is measured in ohms (symbol Ω , the Greek capital omega), defined as

$$1\Omega = 1V/A$$

10.1.2 Resistor Color Code:

Basically a standard describes the way to measure and quantify important properties. There are many standards exist for resistors. Probably, the most common and well-known standard available is the color code marking for carbon resistors. The basis of this system is the use of colors for numerical values, as listed in Table 10.1.

We need to understand how to apply color code system in order to get the correct value of the resistor. We can summarize the different weighted positions of each colored band which makes up the resistors color code in the table 10.2.



Fig:10.1 Resistor

DO YOU KNOW?

Physical size of resistor has its correlation with its power rating. Larger the physical size higher will be the value of its power rating. tolerance is the amount by which the resistance of a resistor may vary from its marked value.

Table.10.1

Colour	Value	Multiplier	Tolerance
Black	0	10^0	-
Brown	1	10^1	-
Red	2	10^2	-
Orange	3	10^3	-
Yellow	4	10^4	-
Green	5	10^5	-
Blue	6	10^6	-
Violet	7	10^7	-
Grey	8	10^8	-
White	9	10^9	-
Gold	-	10^{-1}	5%
Silver	-	10^{-2}	10%
None	-	-	20%

Table 10.2

Number of Colored Bands	3 Colored Bands (E6 Series)	4 Colored Bands (E12 Series)	5 Colored Bands (E48 Series)	6 Colored Bands (E96 Series)
1 st Band	1 st Digit	1 st Digit	1 st Digit	1 st Digit
2 nd Band	2 nd Digit	2 nd Digit	2 nd Digit	2 nd Digit
3 rd Band	Multiplier	Multiplier	3 rd Digit	3 rd Digit
4 th Band	–	Tolerance	Multiplier	Multiplier
5 th Band	–	–	Tolerance	Tolerance
6 th Band	–	–	–	Temperature Coefficient

In a 4 band resistor the first band nearest to the lead gives the first digit, the next band marks the second digit and the third band is the multiplier, which gives the number of zeroes after the two digits. In fig.10.2 (4 Band Resistor) the first stripe is brown for 1 and the next strip is black for 0 and third stripe is orange, a multiplier which means add 3 zeroes to 10. Therefore, the value of R is 10,000 Ω or 10K Ω. The fourth band is golden, which means that the resistor has a tolerance of 5%. Therefore, the resistance value lies between 9.5K Ω and 10.5KΩ. If the tolerance band would be left blank, the result is a 3 band resistor. This means that the resistance value remains the same, but the tolerance is 20%.

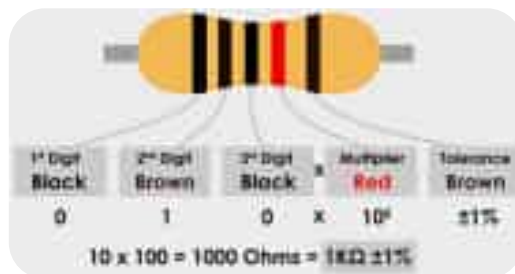

Resistance of 5 Band Resistor

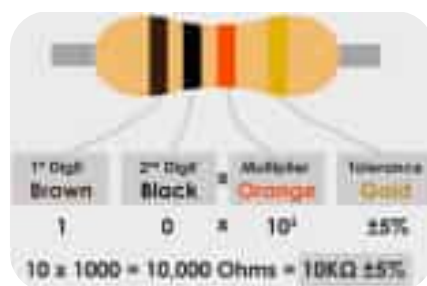

Resistance of 4 Band Resistor

Fig:10.2 (4 and 5) Band Resistors

DO YOU KNOW?

Carbon Composition
 Insulating cover
 Carbon composition
 Lead
 Colour code

Wire Wound Resistor
 Resistance element
 Ceramic core
 Stainless steel End cap

Surface Mount Resistors
 Insulating Protective coating
 Ceramic body

Photo resistor
 Cold weld contacts
 Electrodes
 Ceramic
 Photoconductive material

Non-ohmic materials are substances that do not follow Ohm's Law
 Semiconductor materials: Materials like silicon (Si), germanium (Ge), and gallium arsenide (GaAs) are non-ohmic.

10.2 Resistivity and its dependence upon temperature:

Resistance depends on size and shape. Returning to the analogy with fluid flow: a longer pipe offers more resistance to fluid flow than does a short pipe and a wider pipe offers less resistance than a narrow one. By analogy, we expect a long wire to have higher resistance than a short one everything else being the same and a thicker wire to have a lower resistance than a thin one.

The electrical resistance of a conductor of length L and cross-sectional area A can be written:

$$R \propto L/A$$

$$R = \rho L/A \quad \dots\dots(10.2)$$

The constant of proportionality ρ , which is an intrinsic characteristic of a particular material at a particular temperature, is called the resistivity of the material. The SI unit for resistivity is $\Omega \cdot m$. The resistivity of various substances at $20^\circ C$ is listed in table 10.3.

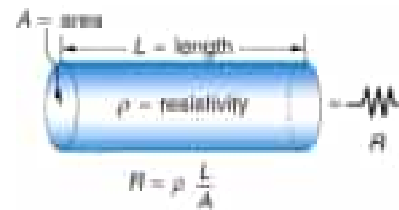

Fig:10.3 Resistivity

10.2.1 Resistivity Depends on Temperature:

Resistivity does not depend on the size or shape of the material, but it does depend on temperature. Two factors primarily determine the resistivity of a metal:

1. The number of conduction electrons per unit volume and the rate of collisions between an electron and an ion.
2. The sensitive to changes in temperature. At a higher temperature, the internal energy is greater; the ions vibrate with larger amplitudes. As a result, the electrons collide more frequently with the ions.

Table10.3 Material resistivity and temperature coefficient

Material	Resistivity ρ (ohm m)		Temperature coefficient α per degree C	Conductivity σ $\times 10^7 / \Omega m$
Conductor				
Silver	1.59	$\times 10^{-8}$.0038	6.29
Copper	1.68	$\times 10^{-8}$.00386	5.95
Copper	1.724	$\times 10^{-8}$
Copper, annealed	1.72	$\times 10^{-8}$.00393	5.81
Aluminum	2.65	$\times 10^{-8}$.00429	3.77
Tungsten	5.6	$\times 10^{-8}$.0045	1.79
Iron	9.71	$\times 10^{-8}$.00651	1.03
Platinum	10.6	$\times 10^{-8}$.003927	0.943
Manganin	48.2	$\times 10^{-8}$.000002	0.207
Lead	22	$\times 10^{-8}$...	0.45

Mercury	98	$\times 10^{-8}$.0009	0.10
Nichrome(Ni,Fe,Cr alloy)	100	$\times 10^{-8}$.0004	0.10
Constantan	49	$\times 10^{-8}$...	0.20
Semi conductors				
Carbon* (graphite)	3.60	$\times 10^{-5}$	-.0005	...
Germanium*	1.500	$\times 10^{-3}$	-.05	...
Silicon*	0.1-60	...	-.07	...
Insulator				
Glass	1.10000	$\times 10^9$
Quartz (fused)	7.5	$\times 10^{17}$
Hard rubber	1.100	$\times 10^{13}$

With less time to accelerate between collisions, they acquire a smaller drift speed, thus, the current is smaller for a given electric field. Therefore, as the temperature of a metal is raised, its resistivity increases. The metal filament in a glowing incandescent light bulb reaches a temperature of about 3000 K; its resistance is significantly higher than at room temperature. For many materials, the relation between resistivity and temperature is linear over a fairly wide range of temperatures (about 500°C):

$$\begin{aligned} \Delta R &\propto R_0 \\ \Delta R &\propto \Delta T \\ R_E &= \rho_0(1 + \alpha\Delta T) \\ \rho_t &= \rho_0(1 + \alpha\Delta T) \end{aligned} \quad \dots(10.3)$$

Where, ρ_t = resistivity at temperature T °C
 ρ_0 = resistivity at temperature T₀ °C
 α = linear temperature coefficient of resistivity and has SI units °C⁻¹ or K⁻¹. The temperature coefficients for some materials are listed in table 10.3.
 Note that for semiconductors, $\alpha < 0$. A negative temperature coefficient means that the resistivity decreases with increasing temperature. It is still true, as for metals that are good conductors that the collision rate increases with temperature. However, in semiconductors the number of carriers (conduction electrons or holes) per unit volume increases with increasing temperature: with more carriers, the resistivity is smaller.

DO YOU KNOW?

The resistivity of good conductors is small. The resistivity of pure semiconductors is significantly larger. By doping semiconductors (introducing controlled amounts of impurities), their resistivity can be changed dramatically, and Insulators have very large resistivity (about a factor of 10²⁰ larger than for conductors). Some materials become superconductors ($\rho = 0$) at low temperatures. Once a current is started in a superconducting loop, it continues to flow indefinitely without a source of emf.

10.2.2 Conductance and Conductivity:

It is defined as “The measure of how easily flow of charges (electrical current) can pass through a material” or Conductivity is the ability of a material to conduct electricity and quantifies the effect of matter on current flow in response to an electric field.

Conductance is the reciprocal, or inverse, of resistance. The greater the resistance, the less the conductance and vice versa. It is denoted by symbol “ σ ” and its unit is the mho “ Ω ”, The unit of the mho has been replaced by the unit of *Siemens* (abbreviated by the capital letter “S”).

Conductivity is denoted by Greek letter sigma (σ) and is the reciprocal of the resistivity i.e. $1/\rho$. It is measured in siemens per meter (S/m). Since electrical conductivity $\sigma = 1/\rho$, the previous expression for electrical resistance, R can be rewritten as a function of conductivity.

$$R = L / \sigma A \quad \dots(10.4)$$

DO YOU KNOW?

Mercury was the first superconductor discovered (by Dutch scientist Kammerlingh Onnes in 1911). As the temperature of mercury is decreased, its resistivity gradually decreases--as for any metal – but at mercury's critical temperature ($T_c = 4.15$ K) its resistivity suddenly becomes zero.

Worked Example 10.1

Calculate the resistance of 100 meter rolls of 2.5mm^2 copper wire if the resistivity of copper at 20°C is $1.72 \times 10^{-8} \Omega$ meter.

Solution:**Step 1: Write the known quantities and point out quantities to be found**

Resistivity of copper at $20^\circ\text{C} = \rho = 1.72 \times 10^{-8} \Omega$ meter

Coil length = $L = 100\text{m}$

Resistance = $R = ?$

Cross-sectional area of the conductor = $A = 2.5\text{mm}^2 = 2.5 \times 10^{-6} \text{m}^2$.

Step 2: Write the formula and rearrange if necessary

$$\rho = R A / L$$

$$R = \rho L / A$$

Step 3: Put the values in formula and calculate

$$R = (1.72 \times 10^{-8}) \times 100 / (2.5 \times 10^{-6})$$

$$\mathbf{R = 0.688 \Omega}$$

Result: Resistance will be **688 milli-ohms** or **0.688 Ohms**.

Worked Example 10.2

A 20-meter length of cable has a cross-sectional area of 1mm^2 and a resistance of 5 ohms. Calculate the conductivity of the cable.

Solution:

Step 1: Write the known quantities and point out quantities to be found

DC resistance = $R = 5$ ohms

Cable length = $L = 20\text{m}$

Cross-sectional area of the conductor = $A = 1\text{mm}^2 = 1 \times 10^{-6} \text{m}^2$.

Conductivity = $\sigma = ?$

Step 2: Write the formula and rearrange if necessary

$$\sigma = L / RA$$

Step 3: Put the values in formula and calculate

$$= 20 / 5 \times 1 \times 10^{-6} = 4 \times 10^6 \text{ S/M}$$

$$\sigma = 4\text{MS/m}$$

Thus, Conductivity of Cable is 4MS/m

10.3 Internal Resistance:

Internal resistance is the opposition to the flow of current within a battery, or other sources of voltage, causing heat generation. Due to this reason a cell becomes hot after a period of time.

10.3.1 The effects of Internal resistance of a source of e.m.f on the terminal potential difference:

The internal resistance of a source of electromotive force (e.m.f) has a significant effect on the terminal potential difference across the source. An ideal voltage source is often represented as an ideal voltage source V in series with an internal resistance r . In real-world sources like batteries or power supplies, the internal resistance is a physical characteristic that affects the terminal voltage when a load is connected.

When a load (external circuit) is connected to the voltage source, current flows through both the load and the internal resistance of the source. The flow of current through the internal resistance causes a voltage drop across it, leading to a reduction in the terminal

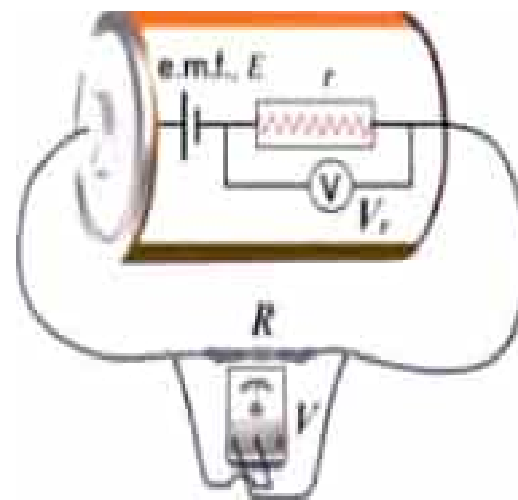

Fig:10.4
Internal resistance of a source

potential difference compared to the ideal voltage source.
Here's how the internal resistance affects the terminal potential difference:

Terminal Potential Difference V_t :

The terminal potential difference V_t is the voltage measured across the terminals of the voltage source when a load is connected. It is the voltage that is available to the external circuit for doing useful work.

Voltage Drop across Internal Resistance:

As current flows through the internal resistance r of the source, there is a voltage drop across it, given by Ohm's Law: $V_{\text{internal}} = Ir$, where I is the current flowing through the circuit.

Terminal Potential Difference Equation:

The terminal potential difference V_t can be calculated as the difference between the ideal voltage of the source V and the voltage drop across the internal resistance:

$$V_t = E - V_{\text{internal}}$$

$$V_t = \mathcal{E} - Ir \dots\dots(10.5)$$

The terminal potential difference V_t is reduced from the ideal voltage V due to the presence of the internal resistance r . The larger the internal resistance, the greater the voltage drop across it, resulting in a more significant reduction in the terminal potential difference.

10.3.2 Energy consideration in e.m.f and potential difference:

The electromotive force \mathcal{E} (e.m.f). It is actually the amount of energy that it provides to each coulomb of charge, whereas the potential difference is the amount of energy used by the one coulomb of charge. The e.m.f transfers the energy in the entire circuit,

The Potential difference V . It is the measure of energy between any two points on the circuit. The electrical energy is gained by the e.m.f in the circuit, whereas electrical energy is lost by the potential difference in the circuit.

The electromotive force can be induced in the magnetic, electric. In contrary, the potential difference can only be generated in an electric field.

DO YOU KNOW?

Electro-motive force can be expressed as a voltage, and is defined as the total amount of energy (in joules) per unit charge (in coulombs) supplied to the circuit.

$$\mathcal{E} = \frac{E}{Q}$$

E = the energy in joules
 Q = the charge in coulombs
 \mathcal{E} = the electro-motive force

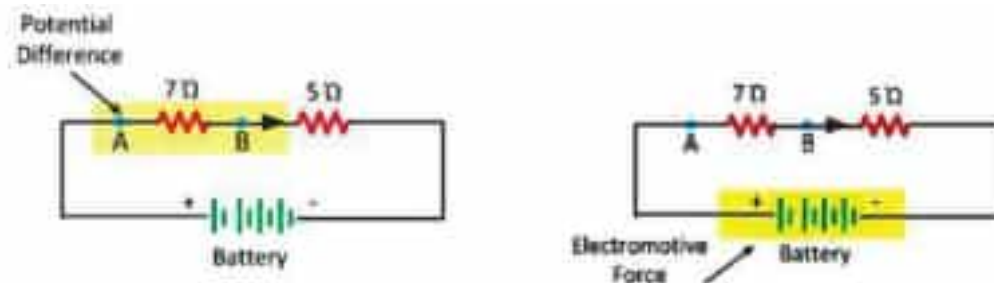

Fig: 10.5 emf and potential difference

The potential difference between the two point charges is expressed by the formula shown below.

$$\text{Potential Difference} = \frac{\text{Energy or Work}}{\text{Charge}}$$

$$V = \frac{E \text{ or } W}{Q} \text{ volts}$$

$$\text{EMF} = \mathcal{E} = \frac{W}{Q} \text{ volts} \quad \dots\dots(10.6)$$

10.3.3 The internal resistance of sources and its consequences for external circuits:

It is important to understand the consequences of the internal resistance of emf sources, such as batteries. Internal resistance affects the performance of emf sources by reducing the potential difference across the external circuit components, which ultimately decreases its ability to supply current and lowers its power output. As the internal resistance of the battery is difficult to measure directly and can change over time, the analysis of circuits is done with the terminal voltage of the battery, as we have done in the previous sections. The internal resistance of a battery can increase for many reasons. For example, the internal resistance of a rechargeable battery increases as the number of times the battery is recharged. The increased internal resistance may have two effects on the battery. First, the terminal voltage will decrease. Second, the battery may overheat due to the increased power dissipated by the internal resistance.

The internal resistance 'r' of a battery can behave in complex ways. It generally increases as a battery is depleted, due to the oxidation of the plates or the reduction of the acidity of the electrolyte. However, internal resistance may also depend on the magnitude and direction of the current through a voltage source and its temperature. The internal resistance of rechargeable nickel-cadmium cells, for example, depends on how many times and how deeply they have been depleted. A simple model for a battery consists of an idealized emf source \mathcal{E} and an internal resistance 'r'.

10.3.4 Sources of emf:

There must be a source of electromotive force (emf) or voltage for electrons to flow. This emf source can be produced from different primary energy sources. These primary sources supply

energy in one form, which is then converted to electric energy. Some Primary sources of electromotive force include:

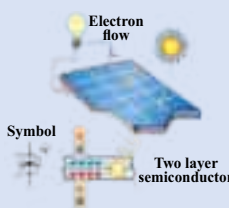
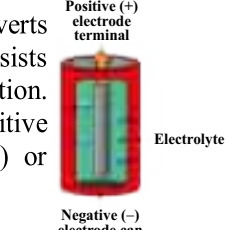
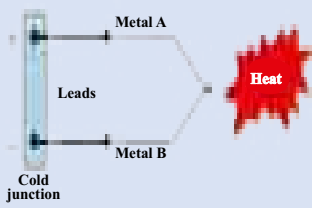
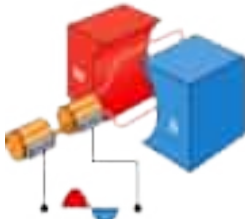
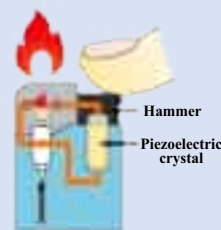
S.No.	Primary Source of emf	Example
1.	Light	<p>A solar or photovoltaic cells and solar module or panel converts solar light to electric energy. These are made up of semiconducting, light-sensitive material which makes electrons available when struck by the light energy.</p> 
2.	Chemical Reaction	<p>A battery or voltaic cell directly converts chemical energy into electric energy. It consists of two electrodes and an electrolyte solution. One electrode connects to the (+) or positive terminal (anode), and the other to the (-) or negative terminal (cathode).</p> 
3.	Heat	<p>Thermocouple converts heat energy directly into electric energy. When we supplied heat to the hot junction, electrons start moving from one metal to the other. This creates a negative charge on one and a positive charge on the other.</p> 
4.	Mechanical-Magnetic	<p>An electric generator converts mechanical-magnetic energy into electric energy. To produce mechanical energy, a generator should be driven by an engine, a turbine or any other machine.</p> 
5.	Piezoelectric Effect	<p>In this type a substance is used which produces an electric charge when a mechanical pressure is applied. Certain crystals like quartz are piezoelectric in nature. They generate an electric charge when they are compressed or struck. A common example of piezoelectricity is the piezo gas igniter.</p> 

10.4 Power Dissipation in Resistors:

It is a fact that resistors always dissipate power. Where does a resistor's power go? By Conservation of Power, the dissipated power must be absorbed somewhere, actually

“The current flowing through a resistor makes it hot; its power is dissipated by heat”.

As the charges Q moves through a resistor, it loses a potential energy $W=VQ$ where V is the potential drop across the resistor. This energy converted into energy of vibration of the atoms into which the charges (electrons) were bumping and has all been converted into heat. This conversion of potential energy into heat refer to as **dissipation**. Hence the power dissipated in a resistor is the energy dissipated per time. If an amount of charge Δq moves through the resistor in a time Δt , the power loss is

$$P = \frac{\Delta qV}{\Delta t} = IV \dots (10.7)$$

Where I is the current through the resistor and V is the voltage drop across it.

The formula $P = IV$ also gives the power generated by a battery if I is the current coming from the battery and V is its voltage.

From Ohms Law, power may also be shown as,

$$\begin{aligned} \text{Power} &= I(IR) \\ \text{Power} &= I^2R \\ \text{Power} &= (V/R)^2R \\ \text{Power} &= \frac{V^2}{R} \end{aligned}$$

If V is in Volts and I in Amperes, then

Power = $I \times V$ = Amperes x Volts = coulomb / second x joule / coulomb = joule / second

Thus resulting units of power is joule per second. The SI unit of power is the watt, where 1 watt = 1 joule per second.

Finally, we have

$$1 \text{ watt} = 1 \text{ ampere} \times 1 \text{ volt}$$

It is a common misconception that Power and Energy/Electricity are same. Interestingly, they have a very different meaning. Power is the rate at which electricity is used and energy is the actual consumption. To give an analogy, power is similar to speed but energy is the actual distance travelled.

So, Power \times Time = Energy

10.4.1 Condition for Maximum power transfer:

The maximum power transfer theorem states that, maximum external power can be obtained from a source with a finite internal resistance, if the resistance of the load is equal to the

DO YOU KNOW?

The English unit of power is horsepower (hp), which is related to the watt by the conversion factor: 1 hp = 746 watt.

DO YOU KNOW?

A unit is represented in kWh or Kilowatt Hour on the electricity bills. This is the energy/electricity actually used. If we use 1000 Watts or 1 Kilowatt of power for 1 hour then we consume 1 unit or 1 Kilowatt-Hour (kWh) of electricity. It means that the electricity meter reading represents the actual usage of electricity. Similarly, a 100-Watt bulb if kept on for 10 hours will consume: $100 \times 10 = 1000 \text{ Watt-Hour} = 1 \text{ Kilowatt-Hour (kWh)} = 1 \text{ units (on our meter)}$.

resistance of the source. This Theorem is another useful circuit analysis method; it ensures that the maximum amount of power will be dissipated in the load resistance when the value of the load resistance is exactly equal to the resistance of the power source.

Consider a circuit in which we have load resistance R_L (Variable 0-100 Ω), internal resistance $R_S = 25 \Omega$ and a voltage supply $V_s = 100V$. We can find the value of the load resistance, R_L that will give the maximum power transfer in this circuit as shown in figure 10.6. By using the Ohm's Law equations:

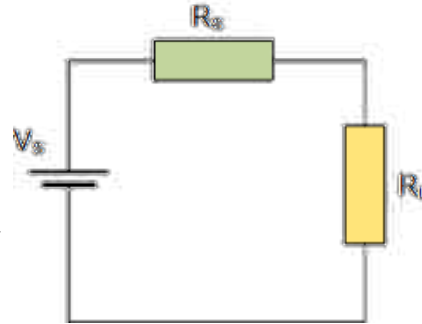

Fig:10.6 Maximum power

$$I = \frac{V_s}{R_s + R_L} \quad \text{and} \quad P = I^2 R_L \quad \dots\dots(10.8)$$

Table 10.4

R_L (Ω)	I (amps)	P (watts)
0	4.0	0
5	3.3	55
10	2.8	78
15	2.5	93
20	2.2	97
25	2.0	100
30	1.8	97
40	1.5	94
60	1.2	83
100	0.8	64

In the table below we have determined the current and power in the circuit for different values of load resistance.

Using the above data, we can plot a graph of load resistance, R_L against power, P for different values of load resistance.

We can see that the **Maximum Power Transfer** occurs when $R_S = R_L = 25\Omega$. It is called a “matched condition” and in this case maximum power is transferred. Also notice that power is zero for an open-circuit (zero current condition) and also for a short-circuit (zero voltage condition). The graph for the power against load resistance is shown below.

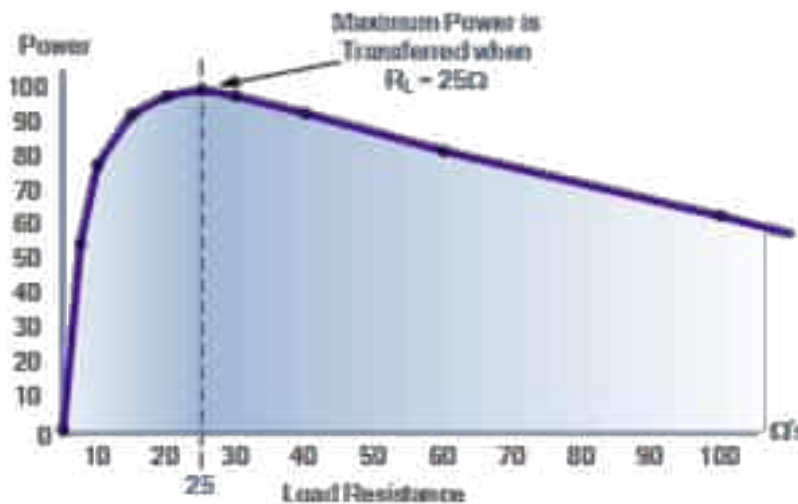

Fig:10.7 Maximum Power transfer

Self-Assessment Questions:

1. A given battery has a 12V emf and an internal resistance of 0.1Ω . Calculate its terminal voltage when connected to a 10Ω load. If the internal resistance grows to 0.5Ω , find the current and terminal voltage.
2. What causes the terminal voltage to be greater than the emf in Cars and in batteries for small electrical appliances and electronic devices while recharging them?
3. A battery that produces a potential difference V is connected to a 5-W light bulb. Later, the 5-W bulb is replaced with a 10-W light bulb. In which case does the battery supply the greatest current?

10.5 Thermoelectricity:

We know that there are various methods for the generation of electricity. It can be generated from wind, using windmills, from water, with the help of hydroelectric power plants, from sun, using solar panels. Similarly, electricity can also be generated from heat energy as well. So thermoelectricity is the electricity generated from heat energy. In thermoelectricity, the conversion of heat energy into electrical energy takes place with the help of a thermocouple.

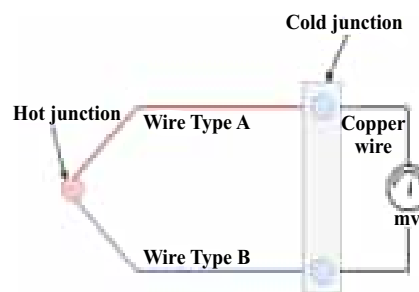

Fig:10.8 Thermocouple

10.5.1 Thermocouple and its function:

The thermocouple is basically a device for measuring temperature. Unlike a thermometer, which relies on the thermal characteristics of a material, a thermocouple is used to measure the temperature at one specific point in the form of EMF or an electric current. It comprises of two dissimilar metal wires that are connected together at one junction where temperature can be measured. The change in temperature of the metal wire stimulates the voltages. It is useful for signaling electronic systems that control household gas devices, such as water heaters and boilers.

10.5.2 Variation of thermoelectric e.m.f with temperature:

Variation of thermoelectric emf with temperature can be studied using an iron-copper thermocouple as shown in Fig.10.10. One junction is dipped in an oil bath and other junction is kept at melting ice (temperature kept constant). Now we observe that:

- The galvanometer shows no deflection when the temperature of both junctions are same (0°C), so thermal emf is also zero
- As the temperature of the hot junction is increased gradually, and the cold junction is remain at 0°C , thermo emf also increase till it becomes maximum. Temperature of the hot junction at which the thermo emf becomes maximum is called neutral temperature (T_n).

- If we increase the temperature of the hot junction beyond neutral temperature, thermo emf starts to decrease and becomes zero and changes its polarity at a temperature called inversion temperature (T_i)
- As the temperature is increased beyond T_i , the direction of thermal emf is reversed. The inversion temperature depends upon the temperature of cold junction and nature of metals used in the thermocouple.

The variation of thermal emf with temperature (T) is given by

$$E = \alpha T + 1/2\beta T^2$$

Where, α and β are constant whose value depends upon material of conductor and the temperature difference of two junctions.

If T_c is the temperature of cold junction, then we can write,

$$T_i - T_n = T_n - T_c \text{ or,}$$

$$2T_n = T_c + T_i$$

Therefore,

$$T_n = \frac{T_c + T_i}{2} \dots\dots(10.9)$$

So, the neutral temperature lies between the inversion temperature and temperature of cold junction.

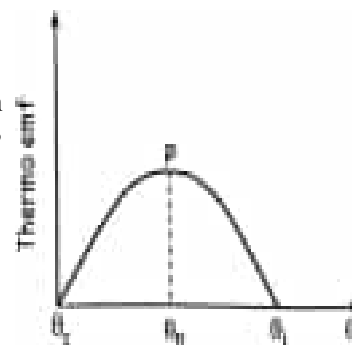
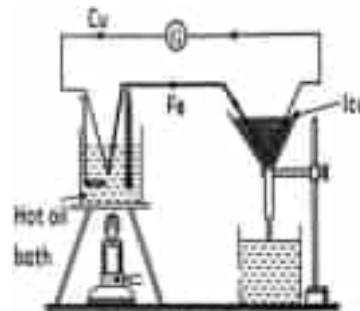

Fig:10.9
Variation of thermoelectric emf

10.5.3 The function of thermistor in fire alarms and thermostats that control temperature:

Fire Alarm:

A thermistor is a variable resistor whose resistance changes with temperature. Its temperature detection can be used in fire alarms for the detection of fires. Fire Alarm Circuit is a simple circuit that detects the fire and activates the Siren Sound or Buzzer.

In this fire alarm circuit, the resistance of the thermistor is approximately in kilo-ohms at normal temperature. During fire, the resistance reduces to a few ohms as the temperature increases which switches ON the *transistor. Once the transistor is turned ON, the current from Vcc starts to flow via buzzer which produces a beep sound. For unidirectional conduction a **Diode is used and the use of capacitor removes sudden transients from the thermistor.

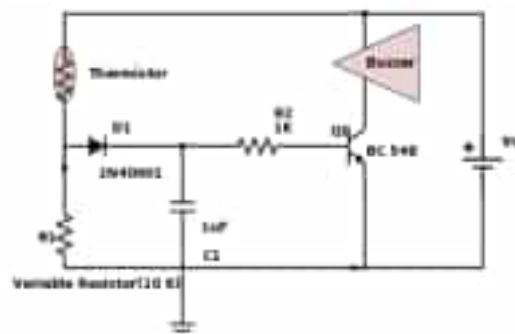

Fig: 10.10 Fire Alarm

Thermostats:

Thermostat is formed by two Greek words thermo and statos, thermos means heat and statos means stationary or fixed. Thermostat is used to control the devices or home appliances according to the temperature, like turn on/off air conditioner, room heaters etc.

The thermostat circuit comprises of a voltage divider circuit and output “ON and OFF” circuit.

Voltage divider circuit comprises of the thermistor and a variable resistor. Voltage divider circuit output is connected to the base of NPN transistor through a $1k\Omega$ resistor. Voltage divider circuit makes it possible to sense the variation in voltage caused by variation in resistance of Thermistor. LED will be switched On, only if temperature crosses a particular value

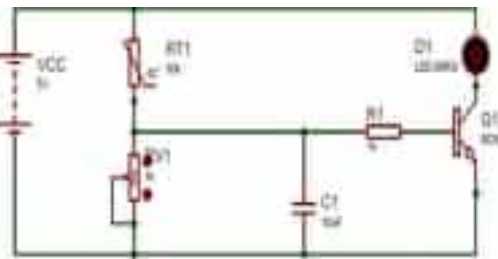

Fig: 10.11 Thermostat

Self-Assessment Questions:

1. Do thermocouples tell you the temperature?
2. Why are two different metals required in a thermocouple?
3. What are the common causes of thermistor failure?

10.6.1 Kirchhoff’s Laws:

Kirchhoff’s laws were stated by German Physicist Gustav Robert Kirchhoff (1824–1887) in 1847. In Physics, Kirchhoff’s laws quantify the way in which current flows through a circuit and the voltage varies around a loop in a circuit. These laws help in simplifying the circuits having multiple resistance networks which are usually very time taking to solve through the combination of resistors in series and parallel. Kirchhoff’s laws can be applied to solve all types of circuits because they are not limited to specific configurations involving series and parallel connections

10.6.1 Kirchhoff’s first law: (Current Law):

You should remember the idea that current may be divided where a circuit splits into two separate branches. The total amount of current remains same after it splits. We would not expect some of the current to disappear, or extra current to appear from nowhere. This is the basis of **Kirchhoff’s first law**, also known as Kirchhoff’s junction rule, which states that “**the current that flows into a junction-any electrical**

DO YOU KNOW?

A diode is a two-terminal electronic component that conducts electricity primarily in one direction.



DO YOU KNOW?

A transistor is a miniature semiconductor that regulates or controls current or voltage flow in addition to amplifying and generating these electrical signals and acting as a switch/gate for them.

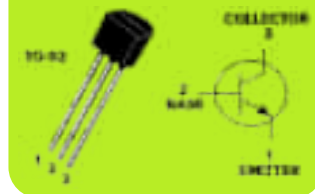

connection-must equal the current that flows out of the same junction". The law can be restated as "the algebraic sum of currents in a network of conductors meeting at a point is zero. The Kirchhoff's Current law is a consequence of the law of conservation of charge. Since charge does not continually build up at a junction, the net rate of flow of charge into the junction must be zero.

We can write Kirchhoff's first law as an equation:

$$\Sigma I_{\text{in}} = \Sigma I_{\text{out}} \dots\dots(10.10)$$

When applying the current law, let current flowing into a junction be positive and current flowing out the junction be negative; then we can say that the net current flowing into a junction is zero.

$$\Sigma I = 0 \quad \dots\dots(10.11)$$

We can also explain Current law diagrammatically as shown in the figures below.

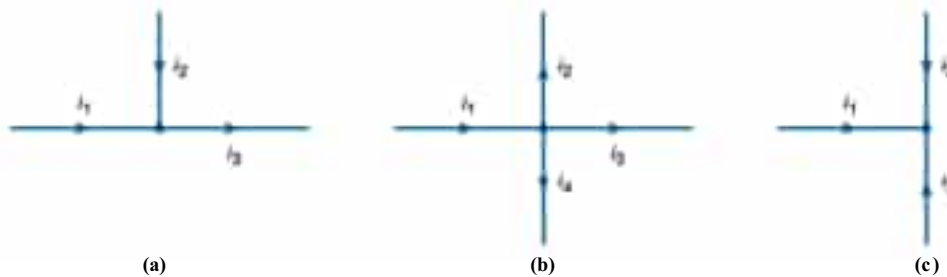

Fig:10.12 Kirchhoff's current law

- In figure A, $i_1 + i_2 = i_3$ or $i_1 + i_2 - i_3 = 0$
- In figure B, $i_1 = i_2 + i_3 + i_4$ or $i_1 - i_2 - i_3 - i_4 = 0$
- In figure C, $i_1 + i_2 + i_3 = 0$

10.6.2 Kirchhoff's second law:

Recall your understanding that the electric potential at any point should have a unique value, it cannot depend on the path one takes to arrive at that point therefore, if a closed path is followed in a circuit i.e. starting and ending at the same point, the algebraic sum of the potential changes must be zero. Think of taking a hike in the mountains, starting and returning at the same spot. No matter what path you take, the algebraic sum of all your elevation changes must equal zero.

The second law, known as Kirchhoff's loop rule or Kirchhoff's voltage law, states that the sum of electromotive forces in a loop equals the sum of potential drops in the loop.

Equation for Kirchhoff's second law:

The Kirchhoff's second law equation can be written as:

$$\Sigma E = \Sigma V \dots\dots(10.12)$$

Where ΣE is the sum of the e.m.f.s and ΣV is the sum of the potential differences. We can also write as:

$$\Sigma \Delta V = 0 \quad \dots\dots(10.13)$$

Kirchhoff's second law is based on the principle of conservation of energy. When a charge, moves around the circuit, it **gains** energy as it passes through each source of e.m.f. and **loses**

energy as it moves through each Potential difference (p.d). During its motion around a closed loop, or circuit charge will end up back to where it started in the circuit and therefore back to the same initial potential with no loss of voltage around the loop. it must have the same energy at the end as at the beginning. So: **energy gained passing through sources of e.m.f. = energy lost passing through components with p.d.s**

For any path in a circuit with same start and end points. (Potential rises are positive: potential drops are negative.). This is well illustrated in the Fig.10.13.

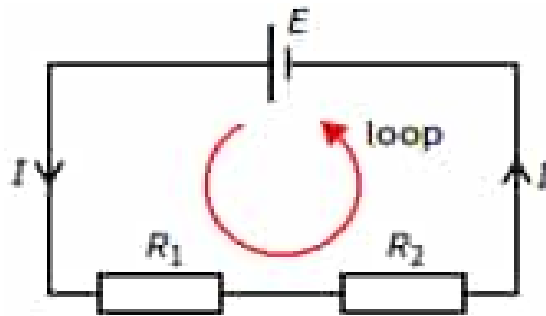

Fig:10.13
Kirchhoff's 2nd law

Consider a simple series circuit which contains a cell and two resistors of resistances R_1 and R_2 , the current I must be the same all the way around, and we need not concern ourselves further with Kirchhoff's first law. For this circuit, we can write the following equation:

$$E = IR_1 + IR_2$$

e.m.f. of battery = sum of p.d.s across the resistors

Directions and Signs:

when the direction of motion is from negative terminal to the positive terminal, the e.m.f of battery is taken as positive. If we move in the opposite direction to the current, then the potential differences of the resistances are taken as positive. It is shown in Fig.10.14.

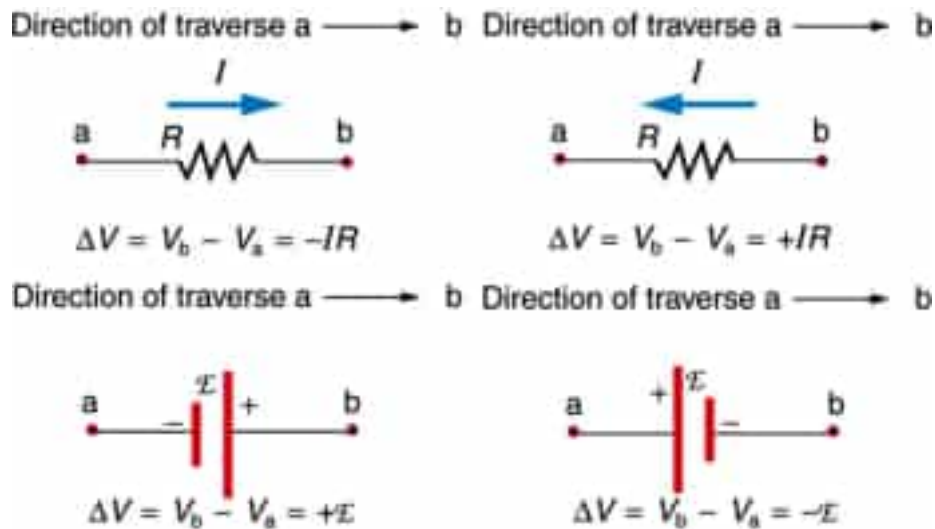

Fig:10.14 Directions of e.m.f and p.d

10.6.3 Kirchhoff's laws for series and parallel resistors combinations:

You are already familiar with the formulae used to calculate the combined resistance R of two or more resistors connected in series or in parallel. To derive these formulae, we have to make use of Kirchhoff's laws.

Resistors in series:

Take two resistors of resistances R_1 and R_2 connected in series (Figure 10.15). According to Kirchhoff's first law, the current in each resistor is the same. The p.d. V across the combination is equal to the sum of the p.d.s across the two resistors:

$$V = V_1 + V_2$$

Since $V = IR$, $V_1 = IR_1$ and $V_2 = IR_2$, we can write:

$$IR = IR_1 + IR_2$$

Cancelling the common factor of current I gives:

$$R = R_1 + R_2$$

For three or more resistors, the equation for total resistance R becomes:

$$R = R_1 + R_2 + R_3 + \dots$$



Fig: 10.15 Resistors in series

Resistors in parallel:

For two resistors of resistances R_1 and R_2 connected in parallel (Figure 10.16), we have a situation where the current divides between them. Hence, using Kirchhoff's first law, we can write:

$$I = I_1 + I_2$$

If we apply Kirchhoff's second law to the loop that contains the two resistors, we have:

$$I_1 R_1 - I_2 R_2 = 0 \text{ V}$$

(Because there is no source of e.m.f. in the loop).

This equation states that the two resistors have the same p.d. V across them. Hence we can write:

$$I = \frac{V}{R}$$

$$I_1 = V/R_1$$

$$I_2 = V/R_2$$

Since, $I = I_1 + I_2$

Therefore, $V/R = V/R_1 + V/R_2$

Cancelling common factor V from both sides

$$1/R = 1/R_1 + 1/R_2$$

For more resistors the equation for total resistance will be

$$1/R = 1/R_1 + 1/R_2 + 1/R_3 + 1/R_4 + \dots$$

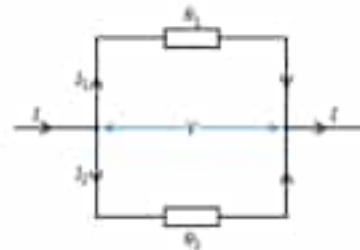
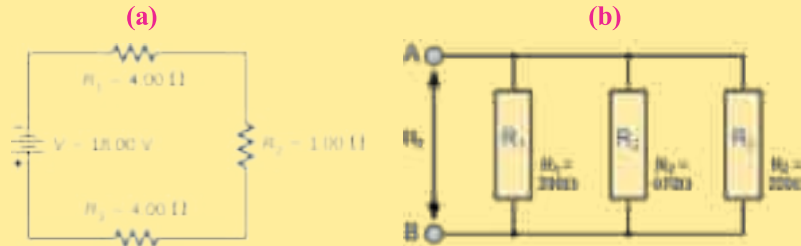

Fig: 10.16 Resistors in parallel

Worked example 3

Determine the equivalent resistance for each of the two circuits shown below:



Solution:

In Circuit (a) the three resistors R_1 , R_2 and R_3 are connected in series.

We know that equivalent resistance of series resistors is given as,

$$R_{eq} = R_1 + R_2 + R_3 + \dots$$

$$\therefore R_{eq} = 4 + 1 + 4 = 9 \Omega$$

In Circuit (b) the three resistors R_1 , R_2 and R_3 are connected in parallel.

We know that equivalent resistance of parallel resistors is given as,

$$\begin{aligned} \frac{1}{R_T} &= \frac{1}{R_1} + \frac{1}{R_2} + \frac{1}{R_3} \\ &= \frac{1}{20} + \frac{1}{40} + \frac{1}{20} = 0.0117 \\ \text{therefore } R_T &= \frac{1}{0.0117} = 85.6 \Omega \end{aligned}$$

Worked example 4:

Find the equivalent resistance of the given circuit

Solution:

We can see that the two resistors, R_2 and R_3 are actually both connected together in a "SERIES" combination. The resultant resistance for this combination would therefore be:

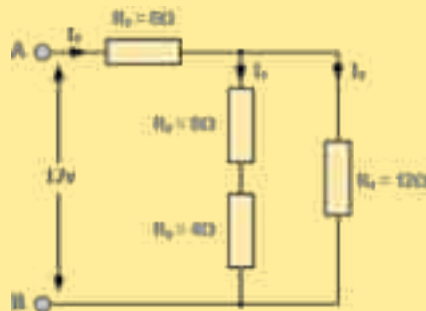

$$R_2 + R_3 = 8\Omega + 8\Omega = 16\Omega$$

So we can replace both resistor R_2 and R_3 above with a single resistor R_A of resistance value 16Ω

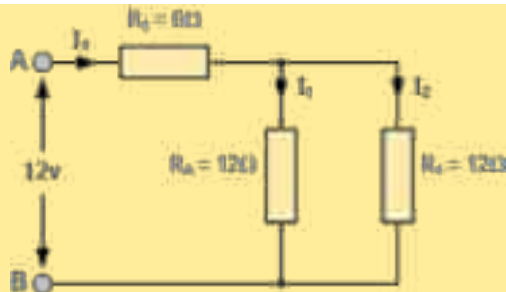

Now our circuit has a single resistor R_A in “PARALLEL” with the resistor R_4 . Using the formula for two parallel connected resistors we can find out its equivalent single resistor.

$$R_{(eq)} = \frac{1}{R_A} + \frac{1}{R_4} = \frac{1}{12} + \frac{1}{12} = 0.1667$$

$$R_{(combination)} = \frac{1}{R_{(eq)}} = \frac{1}{0.1667} = 6\Omega$$

The resultant circuit would be:

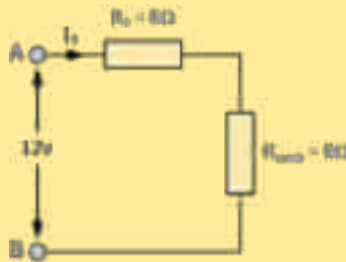

The two remaining resistances, R_1 and $R_{(comb)}$ are connected together in a “SERIES” combination so resultant will be:

$$R_{(ab)} = R_{comb} + R_1 = 6\Omega + 6\Omega = 12\Omega$$

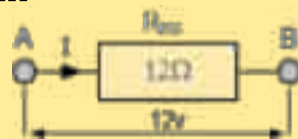

Thus equivalent resistance is of 12Ω . It means the original four resistors connected together in the original circuit above can be replaced by a 12Ω resistor.

Self-Assessment Questions:

1. Can we apply Kirchhoff's laws in the presence of magnetic field?
2. Is it true that Kirchhoff's first law supports law of conservation of charge?
3. Can Kirchhoff's rules be applied to simple series and parallel circuits or are they restricted for use in more complicated circuits that are not combinations of series and parallel?

10.7 Balanced Potential:

Although in today's world digital instruments are providing very accurate measurements but they are costly. However, simple instruments like Wheatstone Bridge and Potentiometer are still providing precise measurements using Balanced potential condition, where no current flows.

10.7.1 Wheatstone Bridge and its uses:

The **Wheatstone Bridge** also known as the resistance bridge is a diamond shaped circuit which was invented by Samuel Hunter Christie in 1833 and Sir Charles Wheatstone later popularized it in 1843. Wheatstone bridge is a setup with four arms (resistors) and the ratio of two of them is kept at a fixed value. The two other arms are balanced, one of which is the unknown resistor whereas the resistance of the other arm can be varied. **A balanced bridge is a Wheatstone bridge circuit with zero output voltage.** When no current passes through a galvanometer, the bridge circuit is said to be balanced. The balancing or null condition is used to compute unknown resistance. The Wheatstone bridge circuit gives a very accurate measurement of resistance. Meter bridge, Carey Foster bridge, Wien bridge and many other instruments are based on the Wheatstone bridge principle.

Principle of Wheatstone Bridge:

The Wheatstone bridge works on the principle of null deflection. In normal conditions, current flows through the galvanometer and the bridge is said to be in an unbalanced condition. Adjusting the known resistance and variable resistance a condition is achieved when no current flows through the galvanometer i.e. a balanced condition.

Working of Wheatstone Bridge:

Wheatstone Bridge Principle states that if four resistance P, Q, R and S are arranged to form a bridge as shown in figure 10.17 with a cell E and one key K1 between the point A and C and galvanometer G and tapping key K2 between the points B and D, closing K1 first and K2 later on, if the galvanometer shows no deflection then bridge is balanced.

Current distribution in the circuit is shown in the figure. Total current by cell is I, it distributed to P and R as I1 and I-I1. The current through galvanometer is Ig.

Current in Q is I-I-Ig and through S current is

$I-I_1+I_g$. Resistance of galvanometer is G.

If we apply Kirchhoff's 2nd law in ABDA, we get

$$I_1 P + I_g G - (I-I_1) R = 0 \quad \dots\dots(i)$$

Now apply Kirchhoff's 2nd law in BCDB, we get

$$(I_1 - I_g) Q - (I-I_1+I_g) S - I_g G = 0 \quad \dots\dots(ii)$$

If value of R is such that the galvanometer shows no deflection that is $I_g = 0$. Putting this value in equation (i) and (ii) we get

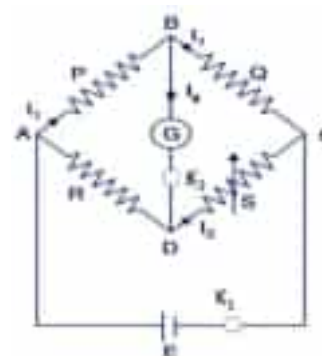

Fig: 10.17
Wheatstone Bridge

$$\frac{P}{Q} = \frac{R}{S}$$

.....(iii)

Equation (iii) relating the four resistors is called the **balance condition for the galvanometer** to give zero or null deflection.

A practical device using this principle is called the **meter bridge**.

10.7.2 Working of rheostat as a potential divider:

A rheostat is a variable resistor, used for controlling the flow of electric current by increasing or decreasing the resistance. The term rheostat is derived from the Greek word “rheos” and “statis” which means current controlling device.

A potential divider is used for getting a variable potential from a fixed potential difference. A potential difference V is provided with the help of a battery across the ends of a variable resistor. If R is the resistance of the wire, the current flowing in the resistor is

$$I = V/R.$$

Let R_{BC} be the resistance of the portion BC of the wire. The current passing through this portion is also I . The PD between the points B and C is given by $V_{BC} = I R_{BC}$

R_{BC} increases as we go away from A and decreases as C comes close to A . This changes the ratio R_{BC} to R and hence a variable voltage can be obtained. If V is regarded as input PD to the potential divider and V_{BC} as the output PD, then V_{BC} can be tapped off and applied to another circuit.

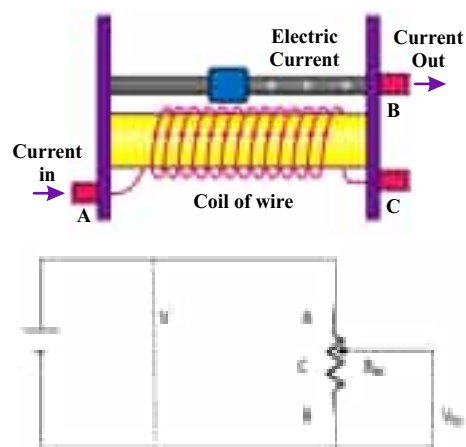

Fig: 10.18

Rheostat as a potential divider

10.7.3 Potentiometer:

A Potentiometer is a three terminal device, consists of a resistance R in the form of a wire on which a terminal C can slide as shown in Fig. 10.19. It is used to compare the e.m.f. of two cells, to measure the internal resistance of a cell, and for accurate measurement of potential difference across a resistor. In many applications it is also used as a variable resistor. It consists of a long wire of uniform cross-sectional area.

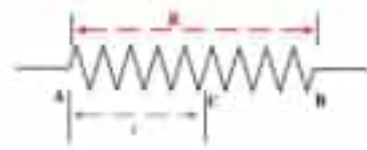

Fig:10.19 Potentiometer

Principle of Potentiometer:

It works on the principle based on the fact that the potential difference across any two points of a wire is directly proportional to the length of the wire, which has a uniform cross-sectional area and the constant current flowing through it.

10.7.3 Describe the function of Potentiometer to measure and compare potentials without drawing any current from the circuit:

Consider a potentiometer of length AB. There are two cells of e.m.fs \mathcal{E}_1 and \mathcal{E}_2 . Now the positive ends of the cells are connected to point 'A' and the negative ends of the cells are connected to the jockey through galvanometer (G). When the key is closed and the jockey is moved along wire AB to find the null point (P) where there is no deflection in the galvanometer (G). Let P_1 be the null point when cell \mathcal{E}_1 is connected and corresponding length between the end A of the wire to the null point P_1 be ' l_1 '. The potential difference across this length balances emf \mathcal{E}_1 .

$$\mathcal{E}_1 = Kl_1 \dots \dots \dots (i)$$

Where, K is the potential gradient of the wire.

Then disconnect the cell of e.m.f \mathcal{E}_1 and connect the cell of e.m.f \mathcal{E}_2 in the circuit. Let P_2 be the null point and let ' l_2 ' be the length between the end A of the wire to the null point P_2 . Then we have $\mathcal{E}_2 = Kl_2 \dots \dots \dots (ii)$

By dividing equation (i) by equation (ii), we get

$$\mathcal{E}_1 / \mathcal{E}_2 = l_1 / l_2$$

As we measure the value of l_1, l_2 we can compare the emf of two cells.

Note: The wire should be uniform, and its resistance must be higher. It is also kept in mind that the emf of the battery connected across the wire should be greater than the emf to be compared.

Self-Assessment Questions:

1. In a potentiometer of 5 wires, the balance point is obtained on the 2nd wire. To shift the balance point to the 4th wire, what should be done?
2. When is Wheatstone bridge most sensitive?
3. When rheostat works as a potential divider, which resistance is taken?

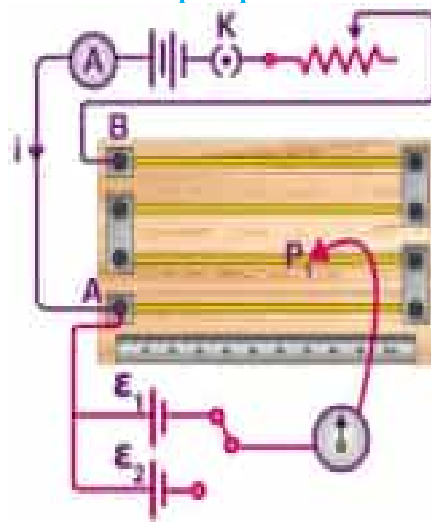

Fig: 10.20(a)

Function of Potentiometer

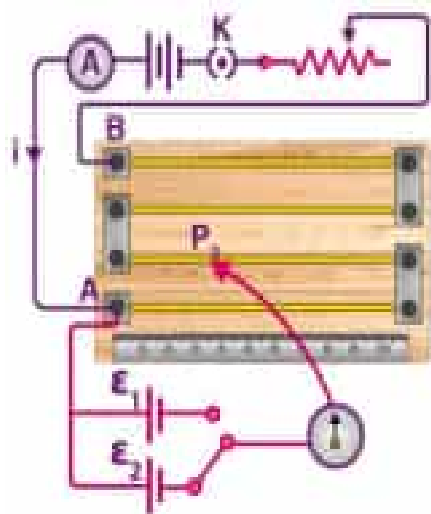

Fig: 10.20(b)

Function of Potentiometer



SUMMARY

- In an electronic circuit, resistors are the electrical components that regulate the flow of electrical current. These resistors vary in their construction, power dissipation capacities, and tolerance to various parameters.
- There are many standards exist for resistors to measure and quantify important properties. Probably, the most common and well-known standard available is the color code marking for carbon resistors.
- Resistivity is the electrical resistance of a conductor of unit cross-sectional area and unit length. Resistivity is a characteristic property of each material and useful in comparing various materials on the basis of their ability to conduct electric currents.
- Conductance is the measure of how easily flow of charges (electrical current) can pass through a material. Mathematically, conductance is the reciprocal, or inverse, of resistance.
- The internal resistance of a battery/cell is the resistance of its electrodes which opposes the flow of current offered by battery and cell itself. The electro-motive force can be expressed as a voltage, and is defined as the total amount of energy (in joules) per unit charge (in coulombs) supplied to the circuit.
- The maximum power transfer theorem states that, maximum external power can be obtained from a source with a finite internal resistance, if the resistance of the load is equal to the resistance of the source.
- Thermoelectricity is the electricity generated from heat energy.
- Variation of thermoelectric emf with temperature can be studied using an iron-copper thermocouple. One junction is dipped in an oil bath and other junction is kept at melting ice (temperature kept constant).
- A thermistor is a variable resistor whose resistance changes with temperature. Its temperature detection can be used in fire alarms for the detection of fires and in thermostat for temperature control of home appliances.
- Kirchhoff's first law (current Law) states that "the current that flows into a junction-any electrical connection-must equal the current that flows out of the same junction". $\Sigma I_{in} = \Sigma I_{out}$
- The Kirchhoff's second law (voltage law) states that "the sum of electromotive forces in a loop equals the sum of potential drops in the loop i.e $\Sigma E = \Sigma V$ ".
Kirchhoff's laws can be used to find equivalent resistance of resistors. For three or more resistors in series or parallel.
- The Wheatstone bridge circuit gives a very precise measurement of resistance. The Wheatstone bridge works on the principle of null deflection.
- A Potentiometer is a three terminal device used to compare the e.m.f. of two cells, to measure the internal resistance of a cell, and for accurate measurement of potential difference across a resistor.

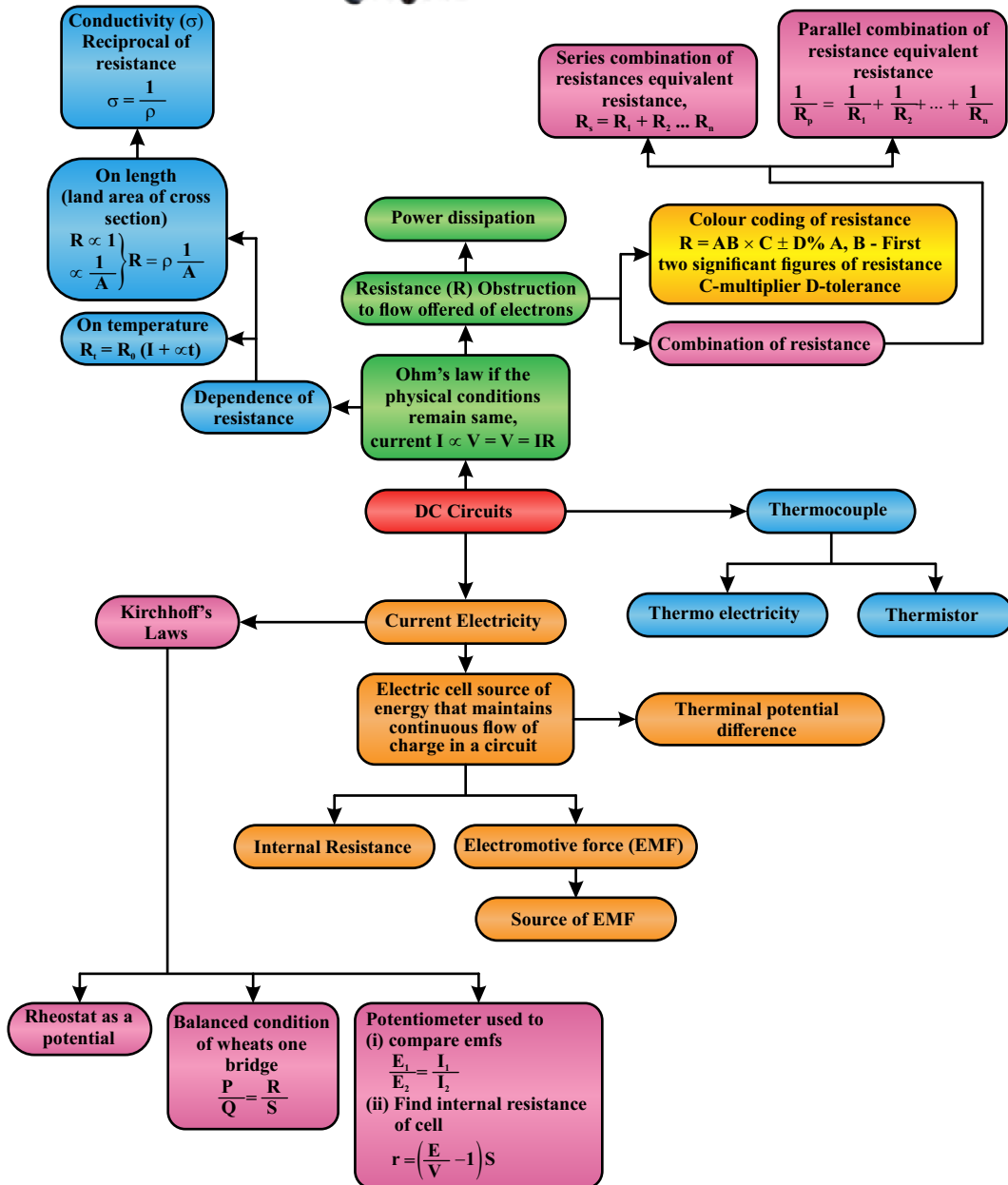



EXERCISE

Section (A): Multiple Choice Questions (MCQs)

- Kirchhoff's laws are useful in determining:
 - current flowing in a circuit
 - emf and voltage drops in a circuit
 - power in a circuit
 - only emf in a circuit
- The resistance of a superconductor is:
 - finite
 - infinite
 - changes with every conductor
 - zero
- Reciprocal of resistance is called:
 - conductance
 - resistivity
 - resonance
 - capacitance
- The graphical representation of Ohm's law is:
 - parabola
 - hyperbola
 - ellipse
 - straight line
- A potential difference is applied across the ends of a wire. If the potential difference is doubled, then the drift velocity of free electrons will:
 - be quadrupled
 - be doubled
 - be halved
 - remain unchanged
- Internal resistance is the resistance offered by:
 - Capacitor
 - resistor
 - Conductor
 - source of emf
- Power dissipation in a resistor can be calculated using which formula:
 - $P = V^2 / R$
 - $P = I^2 \times R$
 - $P = V \times I$
 - $P = R / (V \times I)$
- What is a potentiometer primarily used for?
 - Measuring electric current
 - Measuring electric charge
 - Measuring potential difference (voltage)
 - Measuring electric resistance
- A heat-sensitive device whose resistivity changes with the change in temperature is called:
 - conductor
 - resistor
 - thermistor
 - thermometer
- A wire of uniform area of cross-section A length L and resistance R is cut into two parts. The resistivity of each part:
 - Becomes zero
 - is halved
 - is doubled
 - remains same

CRQs:

- Why is the terminal voltage of a cell less than its emf?
- Why is a potentiometer preferred over a voltmeter for determining the emf of a cell?
- Nichrome and copper wires of same length and same radius are connected in series. Current I is passed through them. Which wire gets heated up more? Justify your answer.
- Explain why the terminal potential of a battery decreases when the current drawn from it is increased?
- What are thermistors? Write their importance.
- State Kirchhoff's Laws.
- If Copper and Aluminum wires of the same length have same resistance, which has the larger diameter? And why?

8. What is the difference between potential difference and emf?

ERQs:

1. State the principle of working of a meter bridge. Explain how it is used to find an unknown resistance.
2. Define thermoelectricity. Explain the working of a Fire Alarm system using thermistor.
3. Define resistivity. Explain dependence of resistivity on temperature.
4. What is a rheostat? How can we use a rheostat as a potential divider?
5. State the underlying principle of a potentiometer. Describe briefly, giving the necessary circuit diagram, how a potentiometer is used to measure the internal resistance of a given cell?

Numericals:

1. The storage battery of a car has an emf of 12 V. If the internal resistance of the battery is 0.5Ω , what is the maximum current that can be drawn from the battery? **(Ans:24A)**
2. A negligibly small current is passed through a wire of length 12m and uniform cross-section $4.0 \times 10^{-7} \text{ m}^2$, and its resistance is measured to be 6.0Ω . What is the resistivity of the material at the temperature of the experiment? **(Ans: $2 \times 10^{-7} \Omega \text{ m}$)**
3. In a potentiometer arrangement, a cell of emf 1.20 V gives a balance point at 40.0 cm length of the wire. If the cell is replaced by another cell and the balance point shifts to 74.0 cm, what is the emf of the second cell? **(Ans: 2.22 V)**
4. **(a)** Three resistors 1Ω , 2Ω , and 3Ω are combined in series. What is the total resistance of the combination? **(Ans: 6Ω)**
(b) If the combination is connected to a battery of emf 24 V and negligible internal resistance, obtain the potential drop across each resistor. **(Ans: $V_1 = 4\text{V}$, $V_2 = 8\text{V}$, $V_3 = 12\text{V}$)**
5. From the given circuit find the value of I.

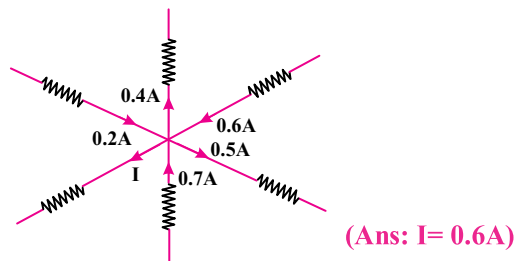

6. In a meter bridge with a standard resistance of 15Ω in the right gap, the ratio of balancing length is 5:3. Find the value of the other resistance. **(Ans: $P = 25 \Omega$)**
7. By using KVL find Current flowing through 10Ω resistance.

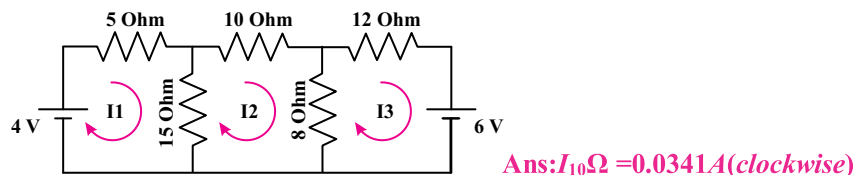



Enjoying on a swing, having a smooth drive on a bike or car on a bumpy road and in today's modern world the most fearsome form of entertainment is bungee jumping. Physics involve in these thrilling phenomena, the motion of a bungee jumper is called Simple Harmonic Motion (SHM).

In this unit student should be able to:

- Describe necessary conditions for execution of simple harmonic motion.
- Investigate the motion of an oscillator using experimental and graphical methods.
- Describe that when an object moves in a circle, the motion of its projection on the diameter of circle is SHM.
- Define the terms amplitude, time period, frequency, angular frequency and phase.
- Identify and use the equation $a = -\omega^2 x$ as the defining equation of SHM.
- Prove that the motion of mass attached to spring is SHM.
- Analyze the motion of a simple pendulum is SHM and calculate its time period.
- Interpret time period of the simple pendulum varies with its length.
- Describe the interchanging between kinetic energy and potential energy during SHM.
- Describe practical examples of free and forced oscillations (resonance).
- Describe graphically how the amplitude of a forced oscillation changes with frequency near to the natural frequency of the system.
- Describe practical examples of damped oscillations with particular reference to the efforts of the degree of damping and the importance of critical damping in cases such as a car suspension system.
- Describe qualitatively the factors which determine the frequency response and sharpness of the resonances.

Along with translational and circular motion, **vibratory** or **oscillatory** motion is one of the most important kinds of motion.

Oscillatory motion is a periodic motion which repeats itself in equal interval of time.

A very common and widely experienced example of vibratory motion is sound.

Other examples of oscillatory motion are;

- Consider a bird in flight flaps its wings up and down. (Fig.11.1)
- A flat strip of metal clamped at one end on the base of table can oscillate up and down when pressed and released from unclamped end.
- A mass suspended by an elastic spring when pulled down and released
- The motion of the bob of simple pendulum when displaced from its mean position and released.
- The atoms or molecules in solid substances oscillate about their mean position. (**equilibrium**)
- Tall buildings and bridges seem to be rigid but they oscillate about their mean position

The vibrations or oscillations occur near the point of stable equilibrium of a particle or system of particles.

“An equilibrium point is stable if the net force acting on the particle for its displacement from equilibrium points back toward the equilibrium point. Such a force is called restoring force”.

Since it tends to restore equilibrium of the particle (Fig.11.2).

11.1 Simple Harmonic Motion:

Simple Harmonic Motion (**SHM**) is a type of oscillation or vibratory motion produced under the action of restoring force.

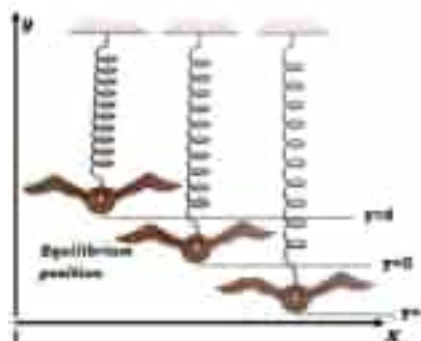

Fig: 11.1

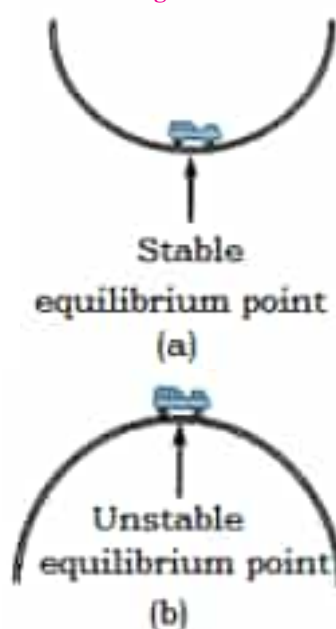

Fig: 11.2

(a) A point of stable equilibrium for a roller-coaster car. If the car is displaced slightly from its position at the bottom of the track, gravity pulls the car back toward the equilibrium point. (b) A point of unstable equilibrium for a roller-coaster car. If the car is displaced slightly from the top of the track the gravity pulls the car away from the equilibrium point.

11.1.1 The necessary conditions for the execution of simple harmonic motion are;

1. The restoring force shall be directly proportional to the displacement from equilibrium position.
2. The restoring force shall be proportional to the inertia (elastic limit) of the system executing SHM.
3. The displacement from the equilibrium point on either side should be small.
4. The force and displacement should follow the Hooke's law ($F = -kx$), where k is 'spring constant or force constant' depends upon the nature of material of spring.
5. Acceleration of the oscillating object should be proportional to the displacement ($a \propto -x$), the negative sign indicates that acceleration is directed towards the equilibrium position O.

11.1.2 Motion of an Oscillator:**(Experimental methods)**

Consider a system of “the mass and spring system” oscillating in horizontal and vertical directions executing simple harmonic motion.

Horizontal Mass-Spring System:

Consider a spring with spring constant k and negligible mass. An object of mass m is attached to one end of the spring whose other end is fixed by a rigid support as shown in Fig.11.3. The spring-mass system can slide on a frictionless horizontal surface. Since the normal reaction force R on the object is balanced by the weight (mg), the net force acting on the object is due to spring. When the spring is at mean position the net force is zero; and the system object is in equilibrium.

If a force F is applied on the object to pull it along the horizontal surface towards right side. The object is displaced from its equilibrium point O for a distance x .

$$F \propto x$$

or
$$F = kx \quad \dots\dots(11.1)$$

“Due to elasticity, the force (equal and opposite) obeying the Hooke's law and is stored in the spring - mass system called elastic restoring force”.

The motion of an object under an elastic restoring force about a fixed point (equilibrium point O) between two extreme point (A, -A) at equal distance from O is a type of oscillatory (vibratory) motion called Simple Harmonic Motion (or SHM).

So restoring force is,

$$F_{res} = -kx \quad \dots\dots(11.2)$$

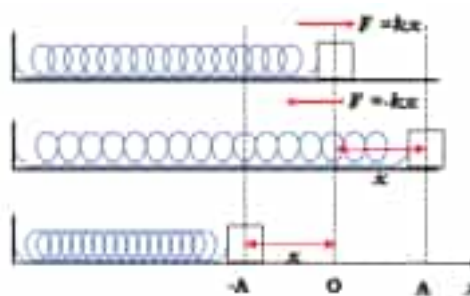

Fig: 11.3

(A horizontal spring mass system to understand the simple harmonic motion under elastic restoring force)

Unit 11: Oscillations

where the negative sign indicates that the elastic restoring force is opposite in direction to the displacement from equilibrium point.

If, now the object is released from A, it begins to oscillate about the equilibrium position between two points A and $-A$

Using $F = ma$ from Newton's second Law of motion in equation 11.2

We have;

$$\begin{aligned} ma &= -kx \\ a &= -\frac{k}{m}x \quad \dots\dots(11.3) \end{aligned}$$

Thus, the acceleration and displacement are always in opposite directions.

As; $\frac{k}{m}$ is a constant; so whenever the acceleration is a negative constant times the displacement the motion is **SHM**.

$$a \propto -x$$

The acceleration of a body executing simple harmonic motion at any instant shall always be proportional to displacement and is always directed towards its equilibrium position.

Self-Assessment Questions:

1. Describe the motion of a mass-spring system in simple harmonic motion (SHM).
2. What are some real-world applications of mass-spring systems?

Graphical representation of SHM:

To understand the simple harmonic motion graphically, we set up an experiment (Fig. 11.4a) with an object attach to a spring. The object oscillates with a maximum displacement x_0 from its equilibrium position. At the same moment a pin projected up and fitted on a horizontal circular disc of radius $R = x_0$ is set into motion with constant angular speed ω . The two objects are set into motion at same instant.

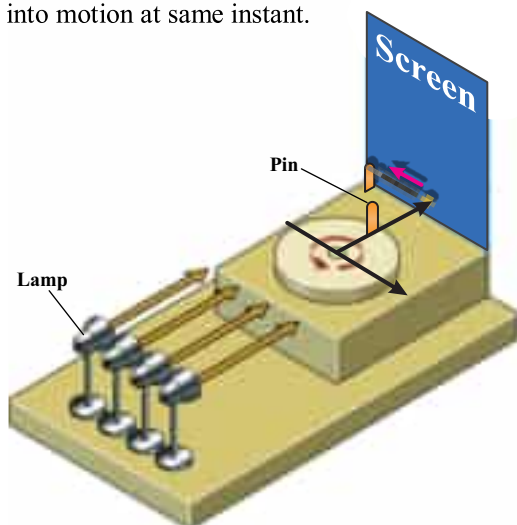

Fig: 11.4 (a) an experiment to show the relation between uniform circular motion and simple harmonic motion

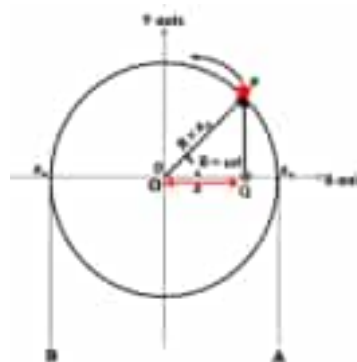

Fig: 11.4 (b)
The motion of the pin moving counter clockwise around a circle of $R = x_0$ as the disc rotates with constant angular speed ω .

Both the pin and the object attached to the spring are illuminated so that the shadows of the pin on the rotating disc and the oscillating object are seen on the screen. The speed of the disk is adjusted until the shadows oscillate with the same period.

Displacement- time (x-t) graph:

We analyze the uniform circular motion of the pin P fitted on a disc of radius x_0 . Figure 11.4(a, b) shows that the pin moves counter clock wise along the circle of radius x_0 with constant angular velocity ω . the displacement – time graph shown in figure 11.5. Let at an instant $t = 0$ the pin starts at A. The position of projection Q is also at A i.e. $x = x_0$. (Fig.11.4b) When pin covers the quarter of its rotation in $t = \frac{1}{4}T$ the projection Q is at $x = 0$ and reaches at B in next $\frac{1}{4}T$. Same motion is now repeated from B to A in next $\frac{1}{2}T$. Similar pattern can be seen in the motion of object attach to the spring.

At any time $t = t$ the angular displacement of the pin is given by;

$$\theta(t) = \omega t$$

The motion of pin's projection (shadow) Q on the screen has the same x-component as the pin itself. Consider a right angle triangle OQP, (Fig.11.4b) we find that

$$x(t) = x_0 \cos \theta = x_0 \cos \omega t \dots (11.4)$$

Velocity – time (v-t) graph:

The comparison of velocity – time graph shown in figure 11.6 and the displacement –time relation in figure 11.5 explains the interrelationship between the displacement and velocity of the object executing SHM. The shape of the curve for velocity - time relation is also same as that of displacement - time graph (Fig.11.7), but the displacement time graph is one quarter ahead of velocity time graph (Fig.11.6). At time $t = \frac{1}{4}T$ the mass is at equilibrium position O and this is the point where the velocity is maximum.

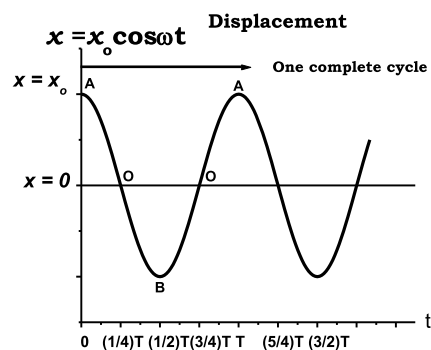

Fig: 11.5 Displacement time graph

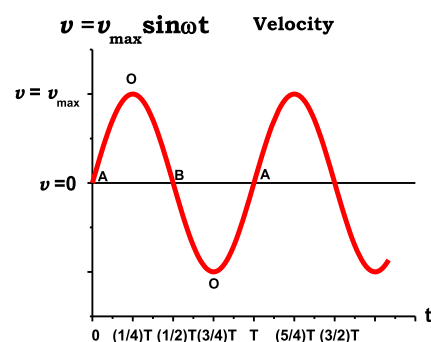

Fig: 11.6 Velocity-time graph

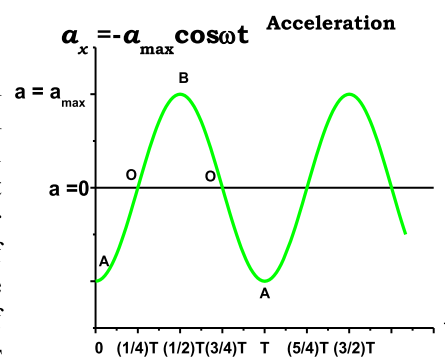

Fig: 11.7 Acceleration-time graph

Acceleration – time (a-t) graph:

In figure 11.7 the relation between acceleration and time is described. At $t = \frac{1}{4}T$ the object is at O and there is no net force acting on it so its acceleration is zero, although the velocity is maximum at equilibrium position. As the object is displaced towards right hand side under the action of a net force $F = kx$, the restoring force $F = -kx$ will act towards left, produces a negative acceleration in the object.

The figure 11.8 shows that acceleration graph is 180° out of phase with displacement graph. This shows that $(a \propto -x)$

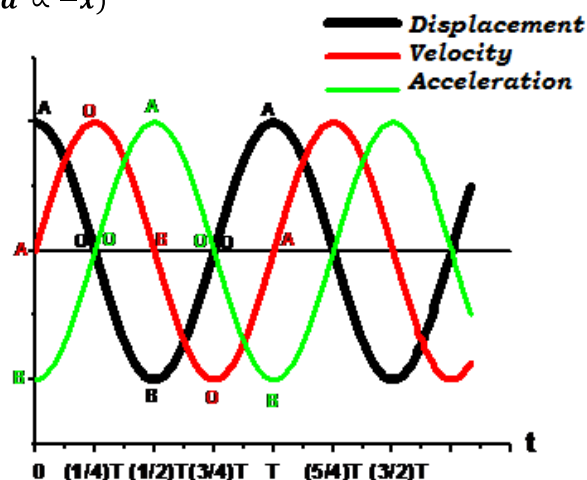

Fig: 11.8

The graph is showing the inter relationship between displacement, velocity and acceleration. At $t=0$ the displacement is $\frac{\pi}{2}$ radians ahead of velocity and reaches at its positive maximum one quarter cycle ahead of velocity. Likewise acceleration is following one quarter cycle to velocity and one half cycles to displacement to reach its positive maximum.

11.2 Uniform Circular Motion and SHM:

The motion of the pin in figure 11.9 a is considered as uniform circular motion. It possesses centripetal acceleration directed towards the center of circle. We know that, the magnitude of centripetal acceleration is given as

$$a_p = \omega^2 r = \omega^2 x_0 \dots (11.5)$$

From figure (11.9) and , the motion of P is along the circumference but its projection Q is oscillating along the diameter AOB. The acceleration of projection Q will be a component of centripetal acceleration of P.

11.2.1 Motion of the Projection of a Particle Moving Along a Circular Path:

In order to establish that projection Q of the particle P, moving along the diameter AOB executes simple harmonic motion as shown in figure 11.9. We shall derive the expression for the acceleration of Q, by resolving the centripetal acceleration of particle P a_p into its rectangular components.

From eq. 11.5.

$$a_x = \omega^2 x_0 \cos \theta \quad \dots\dots (11.6)$$

and

$$a_y = \omega^2 x_0 \sin \theta \quad \dots\dots (11.7)$$

Since a_x is the component along the diameter AOB and always directed towards the equilibrium position O. At any instant t the direction of the acceleration vector is opposite to the direction of the displacement vector. Therefore;

$$a_x = -\omega^2 x_0 \cos \theta \quad \dots\dots (11.8)$$

Consider the right angle triangle OQP (Fig.11.9)

$$\cos \theta = \frac{x}{x_0}$$

Substituting the value of $\cos \theta$ in eq. 11.8

We have; $a_x = -\omega^2 x$

or

$$a_x = \omega^2(-x) \quad \dots\dots(11.9)$$

Since; ω is a constant so ω^2 is also a constant, therefore the acceleration a_x of projection Q moving along the diameter AOB is proportional to the displacement x , complying with the characteristic property of SHM which is;

$$a_x \propto -x$$

Velocity of Projection Q:

The linear velocity v of the particle P moving along a circular path at any instant t and at any point on the circumference shall always be tangent to the circle and perpendicular to the radius of circular path. The magnitude of linear velocity is given as;

$$v_P = \omega x_0 \quad \dots\dots(11.10)$$

As the projection Q is oscillating along the diameter AOB and its motion is due to the motion of P. Therefore the velocity of Q can be determined by resolving v_P into its rectangular components as shown in figure.11.10.

$$v_x = v_P \sin \theta \quad \text{and} \quad v_y = v_P \cos \theta$$

Therefore; $v_Q = v_P \sin \theta \quad \dots\dots (11.11)$

From eq. 11.10, $v_P = \omega x_0$ thus $v_Q = \omega x_0 \sin \theta \quad \dots\dots (11.12)$

Consider the right angle triangle OQP.

$$\cos \theta = \frac{x}{x_0}$$

Using; $\sin^2 \theta + \cos^2 \theta = 1$ and $\sin^2 \theta = 1 - \cos^2 \theta = 1 - \frac{x^2}{x_0^2}$

Therefore; $\sin \theta = \sqrt{1 - \frac{x^2}{x_0^2}}$

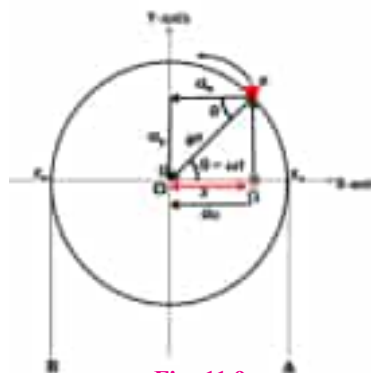

Fig: 11.9
Motion of particle moving along circular path

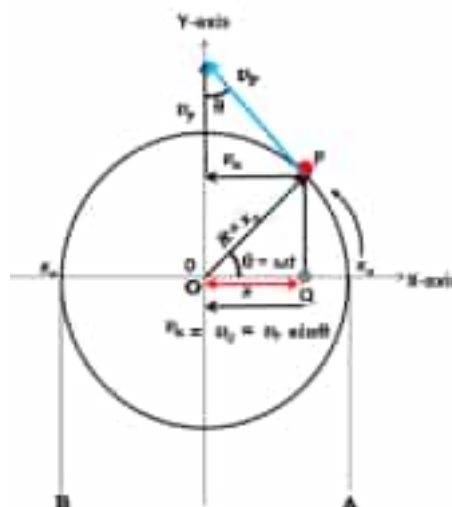

Fig: 11.10 velocity of projection

Unit 11: Oscillations

Putting the value of $\sin\theta$ in eq.11.12

$$v_Q = \omega x_0 \sqrt{1 - \frac{x^2}{x_0^2}} \quad \dots\dots(11.13)$$

Eq. 11.13 represents the instantaneous velocity of projection Q depending upon the position (x) of Q from equilibrium position.

For maximum velocity; $x = 0$ i.e. the projection shall be at equilibrium point O and eq. 11.13 becomes

$$v_{\max} = \omega x_0 \quad \dots\dots (11.14)$$

The velocity shall be minimum if the projection is at the end points of diameter i.e. at A or B, such that $x = x_0$.

Relation between Linear and Uniform Circular Motion:

Since; an oscillating mass attached by an elastic spring (horizontal or vertical) and an object moving along a circular path with constant angular velocity ω has already been proved are executing SHM.

From eqs. (11.3 and 11.9)

$$-\omega^2 x = -\frac{k}{m} x$$

$$\text{Therefore; } \omega = \sqrt{\frac{k}{m}} \quad \dots\dots(11.15)$$

11.2.2 Important terms used in SHM:

Instantaneous Displacement and Amplitude:

When an object is executing SHM, either in spring-mass system or in uniform circular motion its position from its equilibrium point is changed continuously. At any instant t the distance of the object from its equilibrium position is called **instantaneous displacement (x)**. The maximum change in its position is observed when the object is at extreme points i.e. at A or – A (Fig.11.3) or at A or B (Fig.11.5) and the displacement is now termed as **Amplitude (x_0)**.

Period, Frequency and Angular Frequency:

Simple harmonic motion is a periodic motion under the action of elastic restoring force, a body executing SHM repeats the same motion again and again. To complete one cycle or rotation of motion the object must be at the same point and in same direction as it was at the start of the cycle. The same analogy is applied for uniform circular motion.

Time period (T): It is the time taken by the object to complete one cycle of oscillation.

Frequency (f): It is the number of cycles (oscillations, vibrations, and rotations) completed per unit time.

Angular Frequency (ω): It is defined as the ratio of the angular displacement or change in angle (θ) to the time taken (t) to undergo that change. Mathematically, it is expressed as:

$$\omega = \Delta\theta / \Delta t$$

Since the object in Spring-mass system and the pin in uniform circular motion both executing SHM, so we can develop a relation between ω , f and T .

Using; $\theta = \omega T$
where for one complete cycle $\theta = 2\pi$ radians.

It gives; $T = \frac{2\pi}{\omega}$ since $f = \frac{1}{T}$

From eq.(11.18) $\omega = \sqrt{\frac{k}{m}}$

Therefore; eq. (11.19) becomes

$$f = \frac{1}{2\pi} \sqrt{\frac{k}{m}} \quad (11.21)$$

and

$$T = 2\pi \sqrt{\frac{m}{k}} \quad \dots\dots (11.16)$$

It is important to note that in spring-mass system the quantity ω is called the **angular frequency**. It is also be marked that in spring-mass system the ω depends upon mass and spring constant and independent of amplitude.

Phase:

From the discussion we made regarding the displacement and velocity of the particle executing SHM. It is clear that both displacement and velocity are the function of angle ($\theta = \omega t$).

The Phase is the state of motion of a vibrating object in terms of position and direction.

As the particle is rotating along the circumference, its projection Q moves back and forth along the diameter AOB. At $t = 0$ the angle between OP and the reference radial line OA is ϕ , which is called the initial phase. At some later instant t the angle between OR and OA would be $\omega t + \phi$. The phase is Zero at starting point i.e. at equilibrium position A (Fig. 11.11 b) and it would be $\frac{\pi}{2}$ at extreme point O.

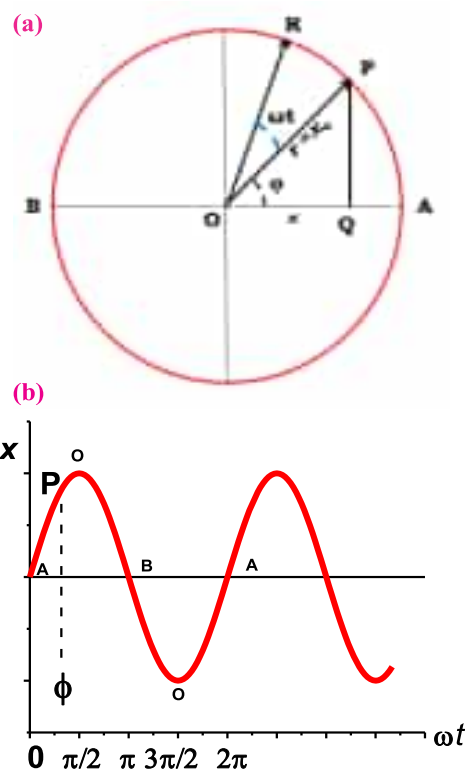

Fig: 11.11

- (a) Motion of a particle along a circular path and
(b) The waveform of the particle motion with an illustration of PHASE.



Fig: 11.12

Astronaut Millie Hughes-Fulford a body-mass measurement device developed for determining mass in orbit.

Unit 11: Oscillations

Consider the right angle triangle OQP from figure 11.11 a, the displacement of point Q from the mean position with respect to position R is given by

$$x = x_0 \cos(\omega t + \phi) \quad \dots\dots(11.17)$$

Worked Example 11.1

The spring used in one such device shown in Fig.11.12 has a spring constant of 606 N/m, and the mass of the chair is 12.0 kg. The measured oscillation period is 2.41 s. Find the mass of the astronaut.

Step 1: Write the known quantities and point out the quantities to be found.

Spring Constant; $k = 606 \text{ Nm}^{-1}$

Mass of chair; $m_{\text{chair}} = 12.0 \text{ Kg}$

Time period; $T = 2.41 \text{ s}$

Step 2: Write the formula and rearrange if necessary.

Since the astronaut and chair are oscillating in simple harmonic motion, the total mass ($m_{\text{total}} = m_{\text{chair}} + m_{\text{astronaut}}$) of the two is related to the angular frequency ω which is related (Eq.11.20) to period of oscillation as

$$T = 2\pi \sqrt{\frac{m_{\text{total}}}{k}}$$

Squaring on both sides and rearranging the above equation.

$$m_{\text{total}} = \frac{T^2 k}{4\pi^2}$$

Hence the expression for mass of astronaut;

$$m_{\text{astronaut}} = \frac{T^2 k}{4\pi^2} - m_{\text{chair}}$$

Step 3: Put the values in the formula and calculate.

$$m_{\text{astronaut}} = \frac{2.41^2 \times 606}{4 \times 3.142^2} - 12.0 = 77.2 \text{ Kg}$$

DO YOU KNOW?

Astronauts who spend a long time in orbit measure their body masses as part of their health-maintenance programs. On earth, it is simple to measure body weight by a scale. However, this procedure does not work in orbit, because both the scale and the astronaut are in free fall and cannot press against each other.

Instead, astronauts use a body-mass measurement device, as shown in Figure. The device consists of a spring-mounted chair in which the astronaut sits. The chair is then started oscillating in simple harmonic motion. The period of the motion is measured electronically and is automatically converted into a value of the astronaut's mass, after the mass of the chair is taken into account.



Worked Example 11.2

A block is kept on a horizontal table. The table is undergoing simple harmonic motion of frequency 3 Hz in a horizontal plane. The coefficient of static friction between the block and the table surface is 0.72. Find the maximum amplitude of the table at which the block does not slip on the surface.

Step 1: Write the known quantities and point out the quantities to be found.

Frequency; $f = 3 \text{ Hz}$

Coefficient of friction; $\mu = 0.72$

Amplitude; $x_0 = ?$

Step 2: Write the formula and rearrange if necessary.

Since $a = \omega^2 x_0$

Maximum force of static friction is given as

$$F = \mu mg$$

In case that the body does not slip;

$$ma = \mu mg$$

or $m \omega^2 x_0 = \mu mg$

and $x_0 = \mu g / \omega^2 = \mu g / (2\pi f)^2$

Step 3: Put the values in the formula and calculate.

$$\text{Amplitude } (x_0) = 0.72 \times 9.8 / (2 \times 3.14 \times 3)^2 = \mathbf{0.0198\text{m}} \text{ or } 1.98\text{cm}$$

Self-Assessment Questions:

- Figure A shows a 10-coil spring that has a spring constant k . When this spring is cut in half, so there are two 5-coil springs, is the spring constant of each of the shorter springs remains same or changed?
- The drawing in figure B shows plots of the displacement x versus the time t for three objects undergoing simple harmonic motion. Which object I, II, or III has the greatest maximum velocity?

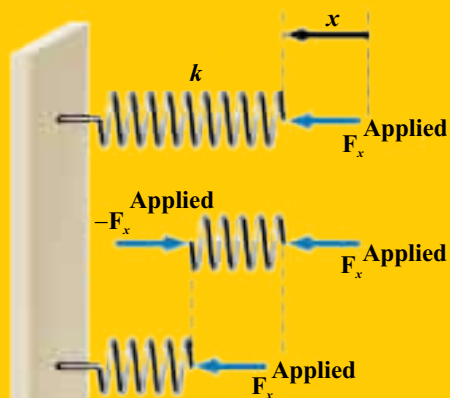

Figure. A

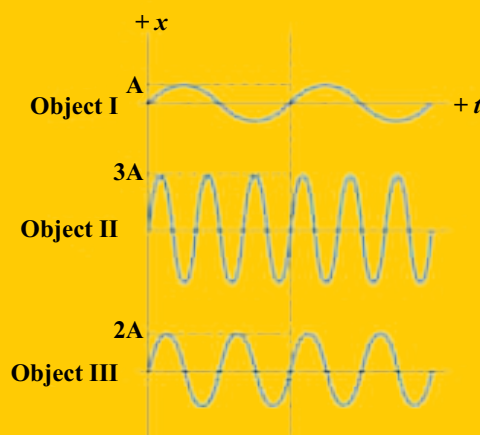

Figure. B

11.3 Practical SHM Systems:

11.3.1 Motion of a Mass Attached to a Spring:

An oscillating mass on a vertical spring also exhibits SHM. The main difference between horizontal and vertical examples is that, in vertical motion of spring-mass system the equilibrium point is moved down under the gravity. Fig. (11.13 a, b, c)

In this example we will consider an ideal spring of negligible mass that obeys Hooke's law. Suppose an object of mass m and weight mg is hung from the spring with spring constant k . The spring is stretched downward under the gravity to a distance d from its relaxed point A and settled at O the equilibrium position. Taking y - axis in upward direction the net force acting on mass at equilibrium is

$$F_{\text{net}} = kd - mg = 0 \quad \dots\dots(11.18)$$

If the object is raised from the equilibrium point O to a position B up to a distance of y , the spring force is less than kd .

The spring force will be

$$F_{\text{res}} = k(d - y)$$

If upward direction of y is taken as positive then the net force acting on the mass at B is

$$F_{\text{net}} = k(d - y) - mg$$

$$F_{\text{net}} = kd - ky - mg$$

From (11.1) $kd = mg$; therefore,

$$F_{\text{net}} = -ky \quad \dots\dots (11.19)$$

As k is a spring or force constant, therefore;

$$F_{\text{net}} \propto -y$$

The restoring force is directly proportional to the displacement from equilibrium point and directed towards the equilibrium position.

Therefore, the vertical mass – spring system exhibits SHM.

Simple Pendulum:

A simple pendulum consists of a point mass suspended from a fixed point by a mass less inextensible string of length L . At equilibrium the weight ($W = mg$) balances the tension T along the string. If the mass is displaced to one side and then released, we assume that for *small amplitude*, the mass moves back and forth along the x -axis.

Suppose at any instant the pendulum makes an angle θ with vertical axis. At A the weight mg may be resolved into its rectangular components

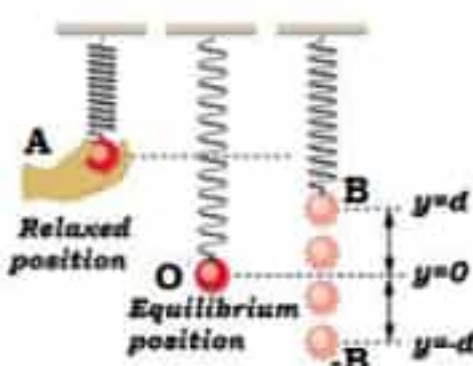

Fig: 11.13

- a) A relaxed spring of spring constant k at A.
- b) The spring is stretched downward under the gravity and reaches at equilibrium point O.
- c) The spring is raised to a distance y

The radial component of the weight along the string $mg\cos\theta$ balances the tension T along the string (Fig.11.14). The tangential component $mg\sin\theta$ provides the necessary restoring force.

Hence $F = -mg\sin\theta$ (11.20)

We expect the restoring force to be proportional to the displacement for small oscillations. Note that the restoring force is proportional to $\sin\theta$ rather than to θ . Moreover if the displacement is large i.e. θ is large the motion is no longer SHM.

However if θ is small and taken in radians then

$\sin\theta \approx \theta$

Hence eq. (11.20) can be re-written as

$$F = -mg\theta$$

Considering $F = ma$ from Newton's second law of motion and substituting in above equation we have

$$a = -g\theta \quad (11.21)$$

Since point O is very close to point A, therefore OA is considered to be a straight line. Using

$s = r\theta$ from figure 11.14

Where $s = x$ the arc length OA and $r = L$

Then $\theta = \frac{x}{L}$

Substituting θ in eq.(11.21), we have

$$a = -\left(\frac{g}{L}\right)x \quad (11.22)$$

Since $\frac{g}{L}$ is a constant

Hence;

$$a = \text{constant} (-x)$$

Or

$$a \propto -x$$

Since; acceleration is directly proportional to displacement and directed towards the equilibrium position, Hence motion of simple pendulum is SHM for small amplitudes.

Time Period of Simple Pendulum:

Time period of the simple pendulum is the time required to complete one oscillation.

To identify the angular frequency we recall that equation 11.9

$$a = -\omega^2x \quad (11.9)$$

Comparing equations 11.9 and 11.22

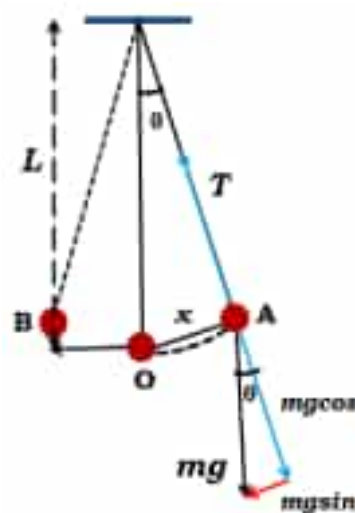

Fig. 11.14
Motion of simple pendulum.

DO YOU KNOW?

Physical Pendulum



Contrary to simple pendulum, where the mass is concentrated at a point. If the mass is uniformly distributed like arms swing and legs movement of a man walking shown in Fig.11.18 then it is called **Physical Pendulum**.

When we walk, our legs alternately swing forward about the hip joint as a pivot. In this motion the leg is acting approximately as a physical pendulum.

$$\omega = \sqrt{\frac{g}{L}}$$

Therefore the time period is

$$T = \frac{2\pi}{\omega} = 2\pi\sqrt{\frac{L}{g}} \quad \dots\dots (11.23)$$

Self-Assessment Questions:

1. Describe the relationship between the period and the gravitational acceleration (g) for a simple pendulum.
2. How does the mass of the pendulum bob affect the period?

11.4 Energy Conservation in SHM:

Consider a spring-mass system, when the mass is pulled towards right and released it moves towards the equilibrium position. The figures 11.3 – 11.15 suggest that the speed is greatest as the object passes through the equilibrium position. The object slows down as it reaches to the end points. This phenomenon indicates the inter conversion of kinetic and potential energies of the system at different points. We will see that these conversions will support the law of conservation of energy. The total mechanical energy of the system at any instant shall remain constant.

E = kinetic energy + Potential energy

11.4.1 Inter Conversion of Kinetic and Potential Energies during SHM:

Kinetic Energy (K) of the Oscillator:

Since the kinetic energy at any instant of the system is given by

$$K = \frac{1}{2}mv^2 \quad \dots\dots (11.24)$$

Where; v is the instantaneous velocity of the system. From eqs. (11.13) and (11.15)

$$K = \frac{1}{2}m \left[x_o \sqrt{\frac{k}{m}} \sqrt{1 - \frac{x^2}{x_o^2}} \right]^2$$

$$K = \frac{1}{2}k(x_o^2 - x^2) \quad (11.25)$$

DO YOU KNOW?

It is important to note down that, in case of simple pendulum the ω is considered as the constant angular frequency of simple pendulum, rather than the angular velocity (rate of change of angular displacement will change with time from zero to maximum). Even both have the same SI unit (radians/s).

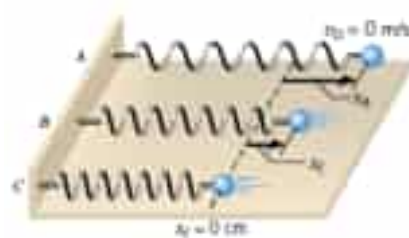

Fig: 11.15 (A) The total mechanical energy of this system is entirely elastic potential energy (B) partly elastic potential energy and partly kinetic energy (C) and entirely kinetic energy.

Eq.11.25 represents the instantaneous kinetic energy of the object executing simple harmonic motion.

Since the speed is maximum at equilibrium position i.e. at $x = 0$. Therefore eq. (11.25) for maximum kinetic energy of the object at equilibrium point.

$$K_{\max} = \frac{1}{2} kx_0^2$$

As the object is instantaneously at rest on extreme position, where $v = 0$ and $x = x_0$.

Therefore;

$$K = \frac{1}{2} k(x_0^2 - x^2) = 0$$

Potential Energy (U) of the Oscillator:

Figure 11.15 suggests that the net force on the oscillator at O is $F_o = \text{zero}$ and at extreme point i.e. at A, it is $F_A = kx$. The average applied force exerted on the system in displacing it from O to A is

$$F_{\text{av}} = \frac{F_o + F_A}{2} = \frac{0 + kx}{2} = \frac{1}{2} kx \quad \dots\dots (11.26)$$

The work done in moving the object from O to A, against the elastic restoring force

$$W = F_{\text{av}} \cdot x = \frac{1}{2} kx^2 \quad \dots\dots (11.27)$$

This work is stored in the spring-mass system as its elastic potential energy U as shown in figure (11.16).

Eq. 11.41 is re-written as

$$U = \frac{1}{2} kx^2 \quad \dots\dots (11.28)$$

Eq.11.27 expresses the instantaneous elastic potential energy of the object executing simple harmonic motion.

Mathematically, in general and practically eq. 11.28 depend upon x , the instantaneous displacement. Hence the potential energy shall be maximum at $(x = \pm x_0)$ are the extreme positions.

$$U_{\max} = \frac{1}{2} kx_0^2 \quad \dots\dots (11.29)$$

and minimum at O where $x = 0$

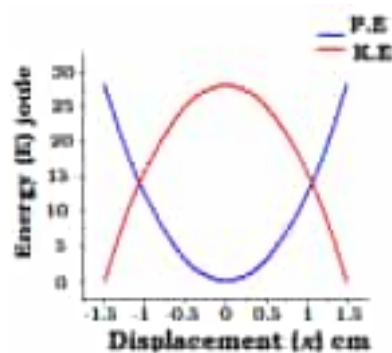
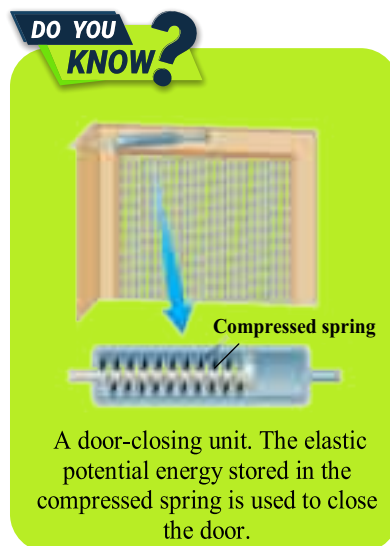

Fig: 11.16 The graph shows the elastic potential energy and kinetic energy as a function of position, for a mass oscillating on a spring.



Total Energy (E) of the Oscillator:

Using equations 11.25, 11.28 and expression of total energy of a system executing SHM can be found as shown in figure 11.17.

$$E = \frac{1}{2}k(x_0^2 - x^2) + \frac{1}{2}kx^2 \quad \dots\dots (11.30)$$

It gives the total energy of a body executing SHM at a distance x , from the equilibrium position.

Simplifying eq. 11.30

$$E = \frac{1}{2}kx_0^2 \quad \dots\dots (11.31)$$

The graphs show that the elastic potential energy is zero where the displacement is zero and maximum at extreme position. Contrary to P.E, kinetic energy is maximum

zero displacement i.e. at equilibrium position and minimum at extreme positions.

The total energy of a body executing SHM at any point is constant.

11.5.1 Free and Forced Oscillations:

In simple harmonic motion, we assume that no dissipative forces such as friction or viscous drag of air exist. Since the mechanical energy is constant, the oscillations supposed to be continued forever with maximum amplitude.

Free Oscillations:

The observation of the motion of an object executing SHM indicates a gradual dying out of amplitude of oscillations.

The amplitude of each cycle is a little smaller than that of the previous one (Fig.11.18), This motion is called damped oscillation.

The word damped is used in the meaning of extinguished or restrained (locked up). For a small amount of damping, oscillations occur at approximately the same frequency as if there were no restrained forces fig.11.19a. An increase in damping decreases the frequency (Fig.11.19b,c) even more damping prevents oscillations from occurring at all (Fig11.19 d).

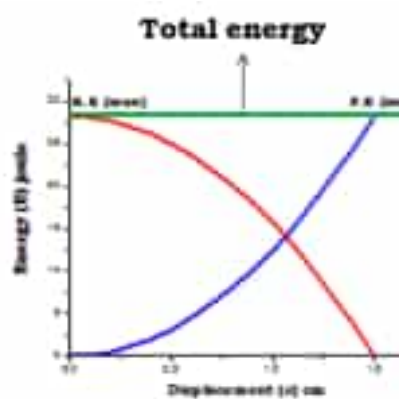

Fig: 11.17



Fig: 11.18

Damped Oscillation. A girl is swinging on a swing. Damping occurs and the swing will oscillate with smaller and smaller amplitude and eventually stop

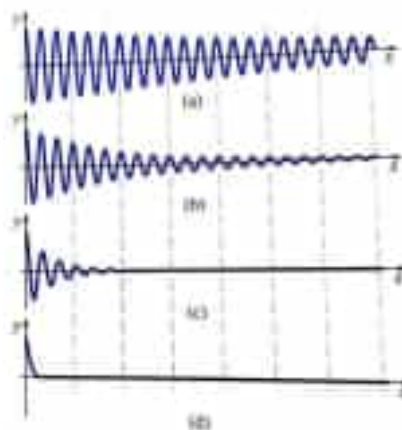

Fig: 11.19

Graphs of displacement $x(t)$ for a system executing SHM, with increasing amount of damping a),b),c) and d).

Graph d) shows that the damping is quite large to stop the oscillation.

11.5.2 Forced Oscillations and Resonance:

When damping forces are present, the only way to keep the amplitude of oscillations from diminishing is to replace the dissipated energy from some other source. When a child is being pushed on a swing, (Fig.11.20) the parent replaces the energy dissipated with a small push. This push keeps the amplitude of motion constant. Every time the parent gives a little push once per cycle that compensates the dissipated amount of energy in one cycle. The frequency of the driving force (*the parent's push*) matches the natural frequency (The frequency at which it would oscillate on its own) of the system.



Fig: 11.20 Forced Oscillation
The applied a certain force to keep the amplitude of oscillation constant.

Resonance:

Forced oscillations occur when a periodic external driving force (push of parent) acts on a system that can oscillate. The frequency of driving force does not have to match the natural frequency of the system. With this driving force the system starts to oscillate with a frequency of driving force although it is far from its natural frequency. However the amplitude is not greatly affected as long as the frequency of driving force is closed to the natural frequency of the system.

If the frequency of external driving force f is continued to increase and if it becomes equal or integral multiple of natural frequency f_0 of the system such that

$$f_{\text{external}} = f_1 \text{ or } = 2f_1 \text{ or } = 3f_1 \dots \dots \text{ or } = n f_1 \dots \quad (11.32)$$

The amplitude of the motion is maximum, this condition is called **resonance**.

At resonance the driving force is always in the same direction as the object's velocity. Since the driving force is always doing positive work, the energy of the

DO YOU KNOW?

MRI magnetic Resonance Imaging system.

Resonance has a very wide range of use in the medical science. Only MRI provided sufficient information about the patient's disease then it is a useful tool. It allows us to see inside the human body with amazing detail, by using magnets and radio waves. It uses magnetic fields and radio waves to measure how much water is in different tissues of the body, maps the location of the water and then uses this information to generate a detailed image. The images are so detailed because our bodies are made up of around 65% water,



oscillator builds up until the dissipation of energy balances the energy added by the driving force. For an oscillator with little damping, the amplitude becomes large (Fig.11.21). When the driving force is not at resonance, some negative work is stored in the system. Hence the net work done by the driving force decreases as the driving frequency moves away from the resonance. Therefore the oscillator's energy and amplitude is smaller than at resonance.

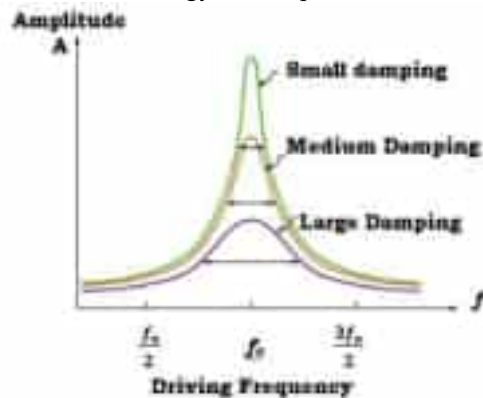

Fig: 11.21

The curves show a relation between amplitude and driven frequency of a harmonic oscillator. The curves represent the same oscillator with the same natural frequency but with different amounts of damping. Resonance occurs when the driving frequency equals the natural frequency.

11.5.3 Practical Example of Damped Oscillations :

Damping is not always disadvantageous. An example of damped oscillation can be seen in a shock absorber used in vehicles as shown in figure 11.22. A shock absorber is a device that is integrated into the suspension system of a car or motorcycle. Its primary purpose is to dampen the oscillations caused by irregularities in the road surface or when the vehicle encounters bumps. In order to compress or expand the shock absorber viscous oil must flow through the holes in the piston. The viscous force dissipates energy regardless of which direction the piston moves. The shock absorber enables the spring to smoothly return to its equilibrium length without oscillating up and down.

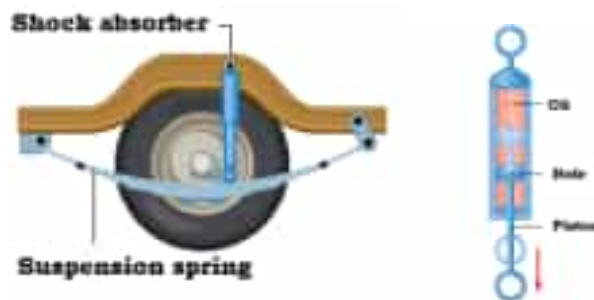

Fig: 11.22

shock absorbers mounted in the suspension system of an automobile, with a simplified cut away view of the shock absorber.

11.5.4 Frequency response and Sharpness of Resonance (Q-Factor):

In most physics and engineering problems the oscillators are analyzed in the limit of small amplitudes. In mechanics problems, an oscillating spring or other structural element has some nonlinearity in its stress-strain curve as the driving force increases and reaches close to the elastic limit.

An oscillating system does not like that an external force resonates with its natural frequency. If you do this the system responds and sometimes its response is catastrophic, the collapse of Tacoma Narrows Bridge is a textbook example of this fact.

On the contrary, when the damping forces are sufficiently strong to restrict the oscillation's amplitude at resonance, the oscillator behaves linearly. This behavior arises because, at resonance, the energy supplied to the oscillator from an external source precisely matches the energy loss due to work done against the damping forces. Increasing damping diminishes the sharpness of resonance (Fig. 11.21), thereby reducing its strength.

The sharpness of resonance depends mainly on two factors: amplitude and damping. The Q-factor quantifies the sharpness of resonance. It signifies the reduction of the oscillation's amplitude over time, which corresponds to the decay of energy in an oscillating system. It is approximately defined as the number of free oscillations the oscillator undergoes before its amplitude decays to zero. In the case of light damping, the Q-factor will be large, whereas it will be small for significant damping. Mathematically, the Q-factor is the ratio of energy stored to energy lost per oscillation, and it is a dimensionless quantity.

$$Q = E_{\text{stored}}/E_{\text{lost}} \quad \dots\dots(11.33)$$

DO YOU KNOW?

In 1940 **Tacoma Narrows Bridge in Washington USA** was collapsed due to increase in amplitude as heavy wind blowing across the bridge resonated with the natural frequency of oscillation of the bridge. This decreases the damping and with the increasing amplitude enormous amount of energy is stored in it which causes the bridge to collapse.



The collapsed, Tacoma Narrows Bridge.



The newly built Tacoma Narrows bridges opened in 1950 (right) and 2007 (left). These bridges are built with much higher resonant frequencies.



SUMMARY

- An equilibrium point is stable if the net force on an object when it is displaced from equilibrium position back towards equilibrium point.
- Vibration occurs in the vicinity of a point of stable equilibrium.
- A force which restores the equilibrium state of a system is called elastic restoring force.
- Simple harmonic motion is periodic motion that occurs whenever the restoring force is proportional to the displacement from equilibrium.
- The acceleration is proportional to and in opposite direction of the displacement: $a_x(t) = -\omega^2 x(t)$.
- In SHM position, velocity and acceleration as a functions of time are sinusoidal (i.e. sine or cosine function).
- An oscillatory motion is approximately SHM if the amplitude is small.
- The maximum velocity and acceleration in SHM are $v_m = \omega x_0$ and $a_m = \omega^2 x_0$.
- The angular frequency for a mass-spring system is: $\omega = \sqrt{\frac{k}{m}}$; where k is spring or force constant.
- The angular frequency for a simple pendulum is: $\omega = \sqrt{\frac{g}{L}}$; where L is length of simple pendulum.
- In the absence of any resistive (dissipative) forces the total mechanical energy of a simple harmonic oscillator at any point is constant and proportional to the square of the amplitude: $E = \frac{1}{2} kx_0^2$
- Resistive forces take out energy from an oscillating system. This takeoff is called Damping.
 - Damping causes the amplitude to decrease with time.
- Resonance is a phenomenon exhibited by an oscillating system, when the system is vibrating under an external driven force close to its natural frequency.
- Q-Factor is the measurement of sharpness of resonance.

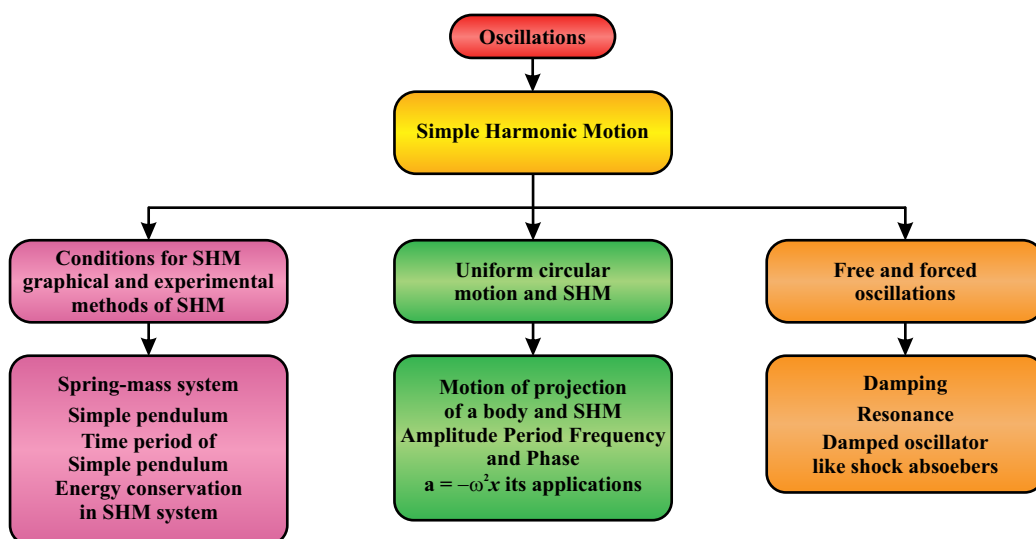



EXERCISE

Section (A): Multiple Choice Questions (MCQs)

- Two simple pendulums A and B with same lengths, and equal amplitude of vibrations, but the mass of A is twice the mass of B, their period are T_A and T_B and energies are E_A and E_B respectively. Choose the correct statement.
 - $T_A = T_B$ and $E_A > E_B$
 - $T_A < T_B$ and $E_A > E_B$
 - $T_A > T_B$ and $E_A < E_B$
 - $T_A = T_B$ and $E_A < E_B$
- In order to double the period of a simple pendulum:
 - Its length should be doubled
 - Its length should be quadrupled
 - The mass should be doubled
 - The mass should be quadrupled
- A simple harmonic oscillator has amplitude A and time period t. Its maximum speed is:
 - $\frac{4A}{t}$
 - $\frac{2A}{t}$
 - $\frac{4\pi A}{t}$
 - $\frac{2\pi A}{t}$
- A spring attached by a load of weight W is vibrating with a period T. If the spring is divided in four equal parts and the same load is suspended from one of these parts, the new time period is:
 - $\frac{T}{4}$
 - 2T
 - $\frac{T}{2}$
 - 4T
- The total energy of a particle executing simple harmonic motion is proportional to:
 - frequency of oscillation
 - maximum velocity of motion
 - amplitude of motion
 - square of amplitude of motion
- A child swinging on a swing in sitting position, stands up, then the time period of the swing will:
 - Increase
 - decrease
 - remains the same
 - increases if the child is long and decreases if the child is short
- If a body oscillates at the angular frequency ω_d of the driving force, then the oscillations are called:
 - Forced oscillations
 - Coupled oscillations
 - Free oscillations
 - Maintained oscillations
- A simple harmonic oscillator with a natural frequency ω_N is forced to oscillate with a driving frequency ω_d . The Resonance occurred when:
 - $\omega_N < \omega_d$
 - $\omega_N > \omega_d$
 - $\omega_N = \omega_d$
 - $\omega_N \approx \omega_d$
- In vehicles, shock absorber reduced the jerks:
 - The shock absorber is the application of damped oscillations.
 - Damping effect is due to the fractional loss of energy
 - Shock absorbers in vehicles reduced jerk
 - All of these
- A heavily damped system has a fairly flat resonance curve in:
 - An acceleration time graph
 - An amplitude frequency graph
 - Velocity time graph
 - Distance-time graph

Section (B): Structured Questions

CRQs:

1. Explain the concept of periodic motion to oscillatory motion. Discuss the terms period, frequency, and amplitude.
2. Explain the concept of phase and phase difference in oscillatory motion. Discuss how phase is related to the position and time in an oscillating system.
3. Explain the concept of damping and its effects on oscillatory motion. Discuss the types of damping, such as over-damping, under-damping, and critical-damping
4. Discuss the concept of resonance frequency and its relationship to the natural frequency of an oscillating system.
5. Discuss the factors that affect the period of a simple pendulum. Explain how the length of the pendulum, the acceleration due to gravity, mass and the amplitude of oscillation influence the period.

ERQs:

1. Define simple harmonic motion (SHM). Discuss the key characteristics of a system undergoing SHM.
2. Derive the equation of motion for a mass-spring system in SHM, illustrating each step of the derivation.
3. Discuss the concept of energy in SHM. Explain how kinetic energy and potential energy vary throughout the motion of a particle in SHM and how the total mechanical energy is conserved.
4. Discuss the concept of resonance in simple harmonic motion. Explain how resonance occurs and its effects on the amplitude and energy transfer in a driven oscillating system.
5. Discuss the factors that affect the sharpness of resonance in an oscillatory system. Explain how damping and quality factor influence the width and peak of the resonance curve.
6. Explain how the period of a mass-spring system can be independent of amplitude, even though the distance travelled during each cycle is proportional to amplitude.
7. A mass hanging vertically from a spring and a simple pendulum both have a period of oscillation of 1s on Earth. The two devices are sent to another planet, where gravitational field is stronger than that of Earth. For each of the two systems, state whether the period is now longer than 1s, shorter than 1s, or equal to 1s. Explain your reasoning.

Numericals:

1. The period of oscillation of an object in an ideal spring and mass system is 0.50 s and the amplitude is 5.0 cm. what is the speed at the equilibrium point? and the acceleration at the point of maximum extension of the spring. **(62.8 cm/s 7.9 m/s²)**
2. A sewing machine needle moves with a rapid vibratory motion, like SHM, as it sews a seam. Suppose the needle moves 8.4 mm from its highest to its lowest position and it makes 24 stitches in 9.0s. What is the maximum needle speed? **(7.0 cm/s)**
3. An ideal spring with a spring constant of 15 N/m is suspended vertically. A body of mass 0.60 kg is attached to the upstretched spring and released.
 - (a) What is the extension of the spring when the speed is a maximum?
 - (b) What is the maximum speed? **[(a) 0.39 m (b) 2.0 m/s]**
4. A body is suspended vertically from an ideal spring of spring constant 2.5 N/m. the spring is initially in its relaxed position. The body is then released and oscillates about its equilibrium position. The motion is described by $y = (4.0\text{cm}) \sin[(0.70\text{rad/s}) t]$. What is the maximum kinetic energy of the body? **(2.0 mJ)**
5. The period of oscillation of a simple pendulum does not depend on the mass of the bob. By contrast the period of a mass-spring system does depend on mass. Explain the apparent condition.
6. What is the period of a simple pendulum of a 6.0 kg mass oscillating on a 4.0 m long string? **(4.01s)**
7. A pendulum of length 75 cm and mass 2.5 kg swings with a mechanical energy of 0.015 J. what is its amplitude? **(3.0 cm)**
8. A pendulum of length L_1 has a period of $T_1 = 0.950$ s. the length of the pendulum is adjusted to a new value L_2 such that $T_2 = 1.00$ s what is the ratio L_2/L_1 **(1.11)**
9. A wire is hanging from the top of a tower such that the top is not visible due to darkness. How do you calculate the height of tower?
10. The amplitude of oscillation of a pendulum decays by a factor of 20.0 in 120 s. By what factor has its energy decayed in that time
(The energy has decreased by a factor of 400)



Sound waves are vibrations occur as a result of interaction of particles either of same nature or different. Humans and other creatures use these sound waves, not only to communicate but also to perform various tasks. To detecting an enemy fighter plane or submarine through RADAR or SONAR

In this unit student should be able to:

- Explain the speed of sound depends on the properties of medium. In which it propagates. And describe the Newton's formula for speed of sound.
- Describe the Laplace correction in Newton's formula for speed of sound.
- Identify the factors on which the speed of sound in air depends.
- Solve problems using the formula $v_t = v_o \sqrt{\frac{T}{273}}$
- Describe the principle of superposition of two waves from coherent sources.
- Understand the phenomena of interference of sound waves.
- Describe the phenomenon of formation of BEATS due to interference of non-coherent source
- Explain the tuning of musical instrument by BEATS
- Explain the formation of stationary waves in using graphical method
- Define the term Node and Anti-Node.
- Describe modes vibration of stationary waves in a string.
- Describe the formation of stationary waves in vibrating an air column.
- Explain the observed change the frequency of mechanical waves coming from moving object approaches or moves away.
- Recall the application of Doppler Effect such as RADAR, SONAR, Astronomy, Satellite and radar speed and traps.
- Outline some cardiac problems that can be detected through the use of the Doppler's Effect.

Speed of sound waves:

Physicists use only a few basic models to describe the physical world. One such model is the particle: a point like object with no inner structure and with certain characteristics such as mass and electric charge. Another basic model is the *wave*.

A wave is characterized by some sort of disturbance in an elastic medium that travels away from its source.

In mechanical waves the particles in the medium are disturbed from the equilibrium position as the wave propagates. After the wave has passed the particles return to their equilibrium position.

Water waves, seismic waves/earthquake and sound waves are the most common forms of mechanical waves. The longitudinal and transverse (stationary or standing) waves both have required a medium to propagate.



Fig: 12.1

12.1 Sound Waves:

Sound is a *longitudinal/mechanical* wave that is created by a vibrating object, such as a guitar string, the human vocal cords, or the diaphragm of a loudspeaker (Fig.12.2).

Sound can be produced and transmitted only in a medium, such as a gas, liquid, or solid

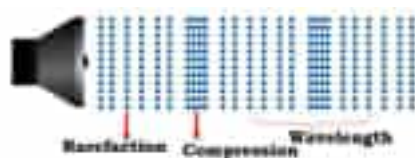

Fig: 12.2

The Physics of a loudspeaker diaphragm.

Sound cannot exist in a vacuum:

When a guitar string is plucked, a transverse wave travels along the string. The vibration of the string is transmitted through the bridge to the body of the guitar, which in turn transmits the vibration to air, called *sound* wave. In the absence of sound wave, air molecules dart around in random directions. On average they are uniformly distributed and the pressure is the same everywhere.

During the propagation of sound wave, the uniform distribution of air molecules (or any medium) is disturbed.

Frequencies of Sound Waves:

The human ear responds to sound waves within a limited

DO YOU KNOW?



When the end of the Slinky is moved up and down continuously, a **Transverse wave** is produced. In such type of wave particles of the medium vibrate perpendicular to the direction of motion of wave.



A back and forth motion of slinky produces **Longitudinal wave**. In such type of wave particles of the medium vibrate along the direction of motion of wave.

range of frequencies. We generally consider the **audible range** to extend from 20 Hz to 20 kHz.

The terms **infrasonic** and **ultrasonic** are used to describe sound waves with frequencies below 20 Hz and above 20 kHz.

12.1.1 Speed of Sound in Air:

The speed of sound in a medium, solid, liquid or gas depends on the elasticity and density of medium.

$$v = \sqrt{\frac{\text{Elastic modulus of medium}}{\text{Density of the medium}}}$$

$$v = \sqrt{\frac{E}{\rho}} \quad \dots\dots(12.1)$$

Newton assumed that the temperature of air (other gases) remains constant when sound waves travel through air. The process is isothermal and Boyle's law can be applied. At compressed regions, pressure increases and volume decreases and in rarefied regions the pressure decreases and volume increases. Under these conditions, the modulus of elasticity is equal to the pressure of the air (gases).

Suppose;

- P = initial pressure
- V = initial volume
- ΔP = increase in pressure
- ΔV = decrease in volume
- $P + \Delta P$ = final pressure
- $V - \Delta V$ = final volume

Using Boyle's law under these conditions,

$$PV = (P + \Delta P)(V - \Delta V) \quad \dots\dots(12.2)$$

$$PV = PV - P\Delta V + \Delta PV - \Delta P\Delta V$$

$$P\Delta V = \Delta PV - \Delta P\Delta V$$

If the change in pressure is small then the corresponding change in volume is also negligible, hence neglecting $\Delta P\Delta V$

Therefore,
$$\frac{P\Delta V}{P} = \frac{\Delta PV}{\Delta V}$$

$$P = \frac{\Delta P}{\frac{\Delta V}{V}}$$

$$P = \frac{\text{Volumetric stress}}{\text{Volumetric strain}} \quad E = B \text{ (Bulk Modulus)}$$

Hence, now be written as,

$$v = \sqrt{\frac{B}{\rho}} \Rightarrow v = \sqrt{\frac{P}{\rho}} \quad \dots\dots (12.3)$$

DO YOU KNOW?

The audible ranges for animals

 Dogs can hear frequencies as high as 50 kHz

 Dolphins make use of frequencies as high as 250 kHz (these are **Ultrasound waves**).

 Elephants communicate over long distances (up to 4 km) using sounds with fundamental frequencies as low as 14 kHz.

 A rhinoceros uses frequencies down to 10 Hz.

Eq. 12.3 is called Newton's formula for speed of sound in air.

Since; $P = \rho_{\text{mercury}} gh$, Eq. 12.3 can now be written as.

$$v = \sqrt{\frac{\rho_{\text{mercury}} gh}{\rho}} \quad \text{----- (12.4)}$$

at STP, $\rho_{\text{mercury}} = 13.6 \text{ gcm}^{-3}$, $g = 981 \text{ cms}^{-2}$ and $h = 76 \text{ cm}$ and density of air $\rho = 1.293 \times 10^{-3} \text{ gcm}^{-3}$

Using these quantities in Eq. 12.4 the speed of sound in air at S.T.P is found to be

$$v = \sqrt{\frac{13.6 \times 981 \times 76}{1.293 \times 10^{-3}}}$$

$$v = 28003.447 \text{ cms}^{-1}$$

The experimental value determined from various experiments for speed of sound waves in air at S.T.P is found to be 33200 cm s^{-1} .

Therefore the theoretical value is 15.6% less than the experimental value of speed of sound.

The large difference in the theoretical and experimental values cannot be attributed to the experimental errors. Newton was unable to explain the error in his formula and the correction was explained by a French scientist Laplace.

12.1.2 Newton's Defect and Laplace Correction:

Newton assumed that propagation of sound waves is an isothermal process. But Laplace thought other way, according to Laplace when sound waves travel through air, there is compression and rarefaction in the particles of the medium. Where there is compression, particles come near to each other and the temperature rises. At rarefaction particles go apart and there is fall of temperature. Therefore, the temperature does not remain constant when sound waves travel through air or any other gas. As sound waves travel through air with a speed of 330 ms^{-1} , the changes in air pressure, volume and temperature is taken place so rapidly. The process is not isothermal but it is adiabatic (Fig.12.3), hence Boyle's law is not applicable. The total quantity of heat of the system as a whole remains constant. It neither gains nor loses any heat through the surroundings.

Table 12.1
Speed of Sound in Various Materials at 0°C and 1 atm (Unless the temperature is mentioned in parenthesis)

Medium	Speed (m/s)
Carbon dioxide	259
Air	331
Nitrogen	334
Air (20°C)	343
Helium	972
Hydrogen	1284
Mercury(25°C)	1450
Fat (37°C)	1450
Water (25°C)	1493
Seawater (25°C)	1533
Blood (37°C)	1570
Muscle (37°C)	1580
Lead	1322
Concrete	3100
Copper	3560
Bone (37°C)	4000
Pyrex glass	5640
Aluminum	5100
Steel	5790
Granite	6500

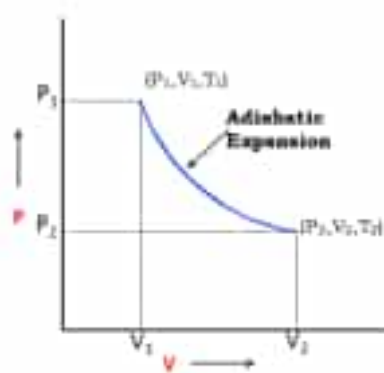

Fig: 12.3
An adiabatic behavior of gas

During an adiabatic process

$$PV^\gamma = \text{constant} \quad (12.5)$$

If pressure of the given mass of the gas changes from P to $P + \Delta P$ resulting to a change of $V + \Delta V$ in volume. Eq. 12.5 can now be written as;

$$PV^\gamma = (P + \Delta P)(V - \Delta V)^\gamma$$

Divide and multiply volume term of (Eq. 12.6) on right hand side with V^γ , we get.

$$PV^\gamma = (P + \Delta P)V^\gamma \left(1 - \frac{\Delta V}{V}\right)^\gamma$$

$$P = (P + \Delta P) \left(1 - \frac{\Delta V}{V}\right)^\gamma$$

Expanding through Binomial theorem and neglecting the square and higher powers of $\frac{\Delta V}{V}$ we get.

$$P = (P + \Delta P) \left(1 - \frac{\gamma \Delta V}{V}\right)$$

$$P = P - \frac{\gamma P \Delta V}{V} + \Delta P - \frac{\gamma \Delta P \Delta V}{V}$$

Neglecting the term $\frac{\gamma \Delta P \Delta V}{V}$,

$$\Delta P = \frac{\gamma P \Delta V}{V}$$

Hence, $\gamma P = \frac{\Delta P}{\frac{\Delta V}{V}} = \frac{\text{Volumetric stress}}{\text{Volumetric strain}} = B$

Eq. 12.3 can now be written as,

$$v = \sqrt{\frac{\gamma P}{\rho}} \quad \dots\dots (12.6)$$

Here γ is the ratio between the two molar specific heats, (C_p , molar specific heat at constant pressure and C_v molar specific heat at constant volume) of air or gas.

For air, $\gamma = 1.42$.

Hence; according to Laplace correction the speed of sound in air is,

$$v = \sqrt{\frac{1.42 \times 13.6 \times 981 \times 76}{1.293 \times 10^{-3}}}$$

$$v = 33369.9 \text{ cms}^{-1} \approx 333 \text{ ms}^{-1}$$

The value of speed of sound is in good agreement with the experimental value 332 ms^{-1} at 0°C .

12.1.3 Factors Affecting the Speed of Sound in Air:

As mentioned earlier that sound waves are compressible mechanical waves, hence the nature and state of the medium affects the propagation of sound wave through the medium. Density of medium, air moisture, pressure, temperature and speed of wind are some of main factors which affect the speed of sound in air.

1. Density of air:

From the relation, $v = \sqrt{\frac{\text{Elastic modulus of medium}}{\text{Density of the medium}}}$

It is clear that speed of sound varies inversely to the square root of density of air.

2. Moisture:

Moisture is the presence of a liquid, especially water in other media, small amounts of water may be found, for example, in the air (called humidity). The presence of moisture in the air decreases the resultant density of air which increases the speed of sound in humidity. Hence the speed of sound in damp (wet) air is greater than in dry air.

3. Pressure:

According to Ideal Gas equation, for 'n' mole.

$$PV = nRT$$

Where, R is Universal gas constant = 8.314 Joule ⁻¹K⁻¹ an T is the temperature in Kelvin.

$$P = \frac{RT}{V}; \quad \dots\dots (12.7)$$

where n is the number of moles

Let m is the mass of the air then ρ (density of air) is given as,

$$\rho = \frac{m}{V} \quad \dots\dots (12.8)$$

Hence the speed of sound in Eq. 12.6 can now be written as,

$$v = \sqrt{\frac{\gamma P}{\rho}} \quad \Rightarrow v = \sqrt{\frac{\gamma n \frac{RT}{V}}{\frac{m}{V}}} \quad \Rightarrow v = \sqrt{\frac{\gamma n RT}{m}}$$

Here; $\frac{m}{n} = M$; called molar mass of the gas (air)

$$v = \sqrt{\frac{\gamma RT}{M}} \quad \dots\dots (12.9)$$

Eq.(12.9) shows that speed of sound is independent of pressure of gas (air)

4. Temperature:

Temperature changes do not affect the speed of sound in liquid and solid media quite significantly. But for a gas (air) the rise and fall of temperature at constant pressure significantly increases or decreases the volume of gas, and thus the density of gas is changes inversely. There is an increase of 0.6 ms⁻¹ in the speed of sound in air for each rise of 1°C in temperature. thus the equation for velocity of sound in air is

$$v_t = v_0 + 0.61t \text{ } ^\circ\text{C} \quad \text{-----}(12.10)$$

Where, v_0 is the speed of sound at (0°C) = 273K = T₀ and

v_t is the speed of sound at (t°C+273)K = T

5. Wind:

If v_w is the wind speed then the speed of sound along the direction of wind relative to ground is ($v + v_w$) and ($v - v_w$) against the direction of wind.

Worked Example 12.1

If the velocity of sound in air at 27°C and at a pressure of 76 cm of mercury is 345 ms⁻¹. Find the velocity at 127°C and 75 cm of mercury.

Solution:

There is no effect of change of pressure on the velocity of sound.

Step 1:

Write the known quantities and point out quantities to be found.

$$T_1 = 27^\circ\text{C} = 27 + 273 = 300\text{K}$$

$$T_2 = 127^\circ\text{C} = 127 + 273 = 400\text{K}$$

$$v_1 = 345\text{ms}^{-1}$$

Required: Speed of sound v_2 at 127°C

Step 2:

Write down the formula and rearrange if necessary

Using equation

$$\frac{v_t}{v_o} = \sqrt{\frac{T}{T_o}}$$

Step 3:

Put the values in the formula and calculate.

$$\frac{v_2}{v_1} = \sqrt{\frac{273+127}{273+27}} = \sqrt{\frac{4}{3}}$$

Hence;

$$v_2 = \frac{2}{\sqrt{3}} \times v_1 = \frac{2}{\sqrt{3}} \times 345 = 398.4 \text{ ms}^{-1}$$

Worked Example 12.2

In a game of cricket match a spectator is sitting in the stand at a distance of 60.0 m away from the batsman. How long does it take the **sound** of the bat connecting with the ball hit for a six to travel to the spectator's **ears**? if the temperature of air is 27°C.

Solution:

Step 1: Write the known quantities and point out quantities to be found.

$$s = 60.0 \text{ m}$$

$$T = 27^\circ\text{C} = 27 + 273 = 300\text{K}$$

Required: t ,

time in which spectator will hear the sound.

Step 2: Write down the formulae and rearrange if necessary

Using equation $v_t = v_o + 0.61t$ °C

and $s = vt$

Step 3: Put the values in the formula and calculate.

$$v_t = 332 + 0.61 \times 27 = 348.47 \text{ ms}^{-1}$$

$$\text{Using } s = v \times t \therefore t = s/v$$

$$t = \frac{60.0}{348.47} = 0.172 \text{ s}$$

Self-Assessment Questions:

- Q.1** What is meant by the terms *isothermal* and *adiabatic* in terms of propagation of sound?
Q.2 Why is speed of sound in solids generally much faster than speed of sound in air (gas)?
Q.3 Why the change in pressure rather than actual pressure is considered in determining the speed of sound in air?

12.2 Superposition of Sound Waves:

Suppose two sound waves of same type pass through the same region of space. Do the waves affect each other? If the amplitudes of waves are large enough, then particles in the medium are displaced far enough from their equilibrium positions that Hooke's law (restoring force \propto displacement) no longer holds; in that case the waves do affect each other. However, for small amplitudes, the waves can pass through each other and emerge unchanged. More generally, when the amplitudes are not too large, the principle of superposition applies:

12.2.1 Principle of Superposition:

When two or more waves overlap, the net disturbance at any point is the sum of the individual disturbances due to each wave.

$$Y_{total} = Y_1 + Y_2$$

Suppose two wave pulses are travelling toward each other on a string (Fig. 12.4). If one of the pulses (acting alone) would produce a displacement y_1 at a certain point and the other would produce a displacement y_2 at the same point, the result when the two overlap is a displacement of $y_1 + y_2$. (Fig. 12.4b, c) show in greater detail how y_1 and y_2 add together to produce the net displacement when the pulses overlap.

The dashed curves represent the individual pulses; the solid line represents the superposition of the pulses. In (Fig. 12.4 b) the pulses are starting to overlap and in (Fig. 12.4 c) they are just about to coincide. The wave pulses pass right through each other without affecting each other; once they have separated; their shapes and heights are the same as before the overlap (Fig. 12.4 a). The principle of superposition enables us to distinguish two voices speaking in the same room at the same time; the sound waves pass through each other unaffected.

12.2.2 Interference of Sound Waves:

The principle of superposition leads to extraordinary effects when applied to coherent sound waves. One way to obtain coherent waves is to get them from same source.

Two waves are coherent if they have the same frequency and they maintain a fixed relationship with each other (Fig. 12.5 a).

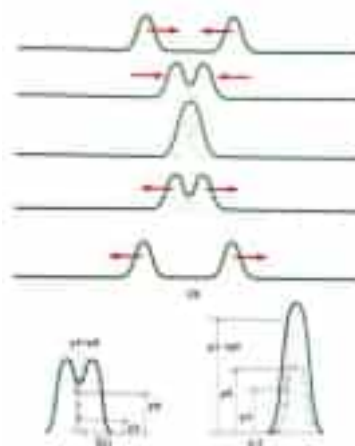
**Fig: 12.4**

(a) Two identical wave pulses travelling toward and through each other. (b) and (c), Details of the wave pulse summation; dashed lines are the separate wave pulse and solid line is the sum

Waves are incoherent if the phase relationship between them varies randomly. Whenever two waves come from two different sources they are incoherent (Fig: 12.5 b).

Suppose coherent waves with amplitudes A_1 and A_2 pass through the same point in space. If the waves are in phase at that point, that is, the phase difference is any even integral multiple of π radians, and then the two waves consistently reach their maxima at exactly the same instant of time (Fig.12.5a).

The superposition of the waves that are in phase that is crest of one falls on the crest of other or trough of one wave falls on the trough of other wave is called *constructive interference*.

The resultant amplitude is the algebraic sum of the individual waves $A = A_1 + A_2$.

Two waves that are 180° out of phase at a given point have a phase difference of π radians, 3π radians, 5π radians and so on. The waves are half a cycle apart; when one reaches its maximum, the other reaches its minimum (Fig.12.5 c).

The superposition of waves that are 180° out of phase is called *destructive interference*.

The amplitude of the combined waves is the difference of the amplitudes of the two individual waves.

12.2.3 Formation of Beats due to interference of non-coherent sources:

The principle of superposition shall be applied to two harmonic travelling waves in the same direction in a medium. The two waves are travelling to the right with same frequency, same wavelength and same amplitude, but differ in phase.

Let y_1 and y_2 are representing the individual displacement of two waves.

$$y_1 = A_0 \sin(kx - \omega t) \text{ and } y_2 = A_0 \sin(kx - \omega t - \varphi)$$

Here $k = \frac{2\pi}{\lambda}$ called wave number

Hence the resultant wave, function displacement is given by,

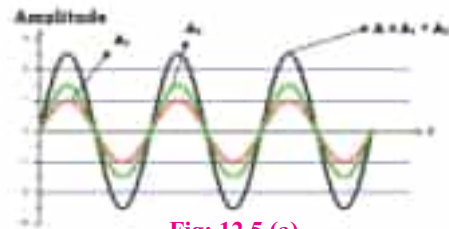

Fig: 12.5 (a)
Two coherent waves with phase difference φ (Red and Green) showing constructive interference.
Destructive Interference

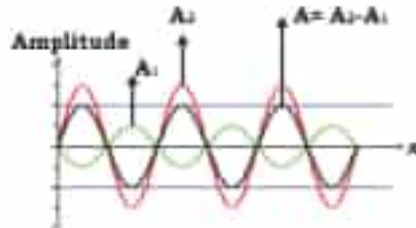

Fig: 12.5 (a) Two non coherent waves red and green are out of phase. The black wave is the resulting wave with smaller amplitude. If both waves have same amplitude then the resulting amplitude shall

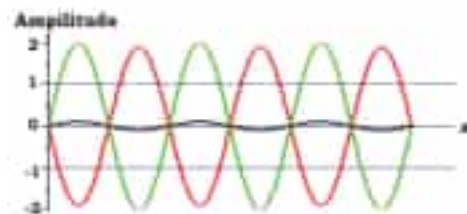

Fig: 12.5 (c) Two coherent waves with 180° phase difference (Red and Green) destructive interference. In order to show the diminishing amplitude of resultant wave (Black)

$$Y = y_1 + y_2 = A_0 \sin(kx - \omega t) + A_0 \sin(kx - \omega t - \phi) \quad \dots\dots (12.11)$$

Using trigonometric identity

$$\sin a + \sin b = 2 \cos\left(\frac{a-b}{2}\right) \sin\left(\frac{a+b}{2}\right)$$

Let $a = kx - \omega t$ and $b = kx - \omega t - \phi$, simplifying equation 12.11, we get

$$Y = 2A_0 \cos\left(\frac{\phi}{2}\right) \sin\left(kx - \omega t - \frac{\phi}{2}\right) \quad \dots\dots (12.12)$$

The resultant wave function Y is also harmonic having same frequency and wavelength as the individual waves with $2A_0 \cos\left(\frac{\phi}{2}\right)$ is the resultant amplitude with phase $\frac{\phi}{2}$. If the phase constant $\phi = 0$ then $\cos\left(\frac{\phi}{2}\right) = 1$ and the resultant amplitude is $2A_0$. This represents the constructive interference.

In general $\phi = 0, 2\pi, 4\pi, 6\pi \dots\dots 2n\pi$. Where ($n = 1, 2, 3, \dots\dots$).

On the other hand if $\phi = \pi, 3\pi, 5\pi \dots\dots n\pi$. Where ($n = 1, 3, 5, \dots\dots$), then the resultant amplitude shall be zero everywhere. This represents destructive interference.

Interference of Sound Waves in Time (BEATS):

When two sound waves are close in frequency (within about 15 Hz of each other), the superposition of the two produces a pulsation that we call beats.

Beats can be produced by any kind of wave; they are a general result of the principle of superposition when applied to two waves of *slightly different frequency*. Beats are caused by the slow change in the phase difference between the two waves.

Suppose at one instant ($t=0T$ in Fig.12.6), the two waves are in phase with each other and interfere constructively. According to the principle of superposition principle, the resultant amplitude is maximum. The sum of the amplitudes of the two waves, shown in Fig.12.7

However since the frequencies are different, the waves do not stay in phase. The higher frequency wave has a shorter cycle, so it gets ahead of the other

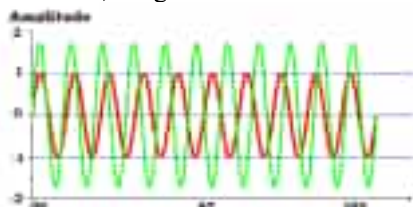

Fig: 12.6
Graph of two sound waves with frequencies f_1 (Red) and f_2 (Green)

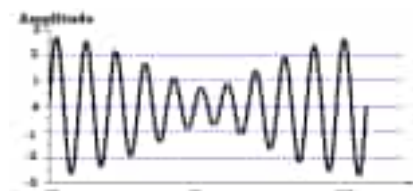

Fig: 12.7
The superposition of two waves has minimum amplitude at $t = 5T$ and maximum amplitude at $t = 10T$

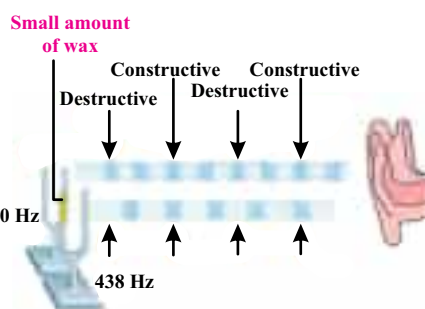

Fig: 12.8
The ear identify the amplitude (intensity) cycling from large to small then small to large and then large to small as pulsation in loudness. Thus, we refer this phenomenon of beats as interference of sound waves in time.

one. The phase difference between the two steadily increases and the resultant amplitude decreases. At a later time ($t = 5T$) the phase difference reaches 180° ; now the waves are half a cycle out of phase and interfere destructively (Fig. 12.8). Now the resultant amplitude is minimum. As the phase difference continues to increase, the amplitude increases until constructive interference occurs.

Beat Frequency:

At what frequency do the beats occur? It depends on how far apart the frequencies of the two waves are. We can measure the time between the beats $T_{\text{beat}} = 1/f_{\text{beat}}$, as the time to go from one constructive interference to the next constructive interference. During that time, each wave must go through a whole number of cycles, with one of them going through one more cycle than the other. Since the frequency f is the number of cycles per second. The number of cycles a wave goes through during a time T_{beat} is $f T_{\text{beat}}$. From (Fig.12.6) T_{beat} is $10T$. During that time wave 1 (red) goes through $f_1 T_{\text{beat}} = 10$ cycles, while wave 2 (green) goes through $f_2 T_{\text{beat}} = 1.1/T \times 10T = 11$ cycles. If f_2 is greater than f_1 then wave two goes through one more cycle than wave 1. Hence;

$$\begin{aligned} f_2 T_{\text{beat}} - f_1 T_{\text{beat}} &= f T_{\text{beat}} = 1 \\ f_{\text{beat}} &= 1/T_{\text{beat}} \\ f_{\text{beat}} &= f_2 - f_1 \quad \dots\dots (12.13) \end{aligned}$$

In this way we obtain a very simple result that the beat frequency is the difference between the frequencies of the two waves. The maximum beat frequency a human ear can detect is about 7 beats per second.

12.2.4 Tuning of Musical Instruments:

All the musical instruments like piano, guitar and clarinet (shehnai) are need to tune after excessive use. The Piano tuners listen the beats as they tune. The tuner sounds two strings and listens for the beats. The beat frequency indicates whether the interval is correct or not. If the two strings are played by the same key, they are tuned to the same fundamental frequency, so the beat frequency should be nearly zero. If the two strings belong to two different notes, the beat frequency is non zero. Actually, in this case the tuner listens to beats between two overtones that are close in frequency, not the fundamentals. The fundamental frequencies are too far apart for the beats to be detected.

12.2.5 Stationary Waves:

Stationary (**Standing**) (Fig.12.10), waves occur when a string is tightly stretched between two rigid supports. If the string is plucked from the half of its length, the crest extends the whole



Fig: 12.9 (a)

A pianist is tuning his piano with proper tuning, care, and maintenance.



Fig: 12.9 (b)

Sindhi Folk musicians are demonstrating their art. With the help of BEATS phenomenon enjoy the beats of dhool and Shahnai

distance between the supports. This distance is clearly half the wavelength of the transverse wave produce in the stretched string. This wave is reflected at the boundary and the reflected wave interferes with the incident wave so that the wave appears to stand still. Suppose that a harmonic wave on a string, coming from left, hits a boundary where the string is fixed.

The equation of incident harmonic sine wave is; $y_1 = A \sin(kx - \omega t)$

and the equation of the reflected sine wave travelling to right is; $y_2 = A \sin(kx + \omega t)$

y_1 and y_2 represents the displacements of incident and reflected waves.

Applying the principle of superposition the motion of the stretched string is described by

$$y = y_1 + y_2 = A [\sin(kx - \omega t) + \sin(kx + \omega t)]$$

Using the trigonometric identity

$$\sin \alpha + \sin \beta = 2 \left[\frac{1}{2} \sin(\alpha + \beta) \right] \left[\frac{1}{2} \cos(\alpha - \beta) \right]$$

Here, $\alpha = kx - \omega t$ and $\beta = kx + \omega t$ we have;

$$y = 2A \sin kx \cos \omega t \quad \dots \dots (12.14)$$

The resultant expression is the wave function of a standing wave obtained due to the superposition of two waves of the same amplitude and frequency moving with same speed in opposite direction along same axis.

12.2.6 Nodes and Antinodes:

In standing wave, different points move with different amplitudes, but every point reaches its maximum distance (amplitude) from equilibrium at the same time and same frequency. The amplitude of a particle at any point x is $2A \sin kx$.

Figure.12.13 shows that,

The points which never move labeled as ‘N’ having minimum (ZERO) amplitude are called NODES.

From equation 12.14 we can determine the position of nodes. The nodes are the points where $\sin kx = 0$. Since $kx = n\pi$ ($n = 0, 1, 2, 3, \dots$). By putting $k = \frac{2\pi}{\lambda}$, the wave number, the position of nodes are

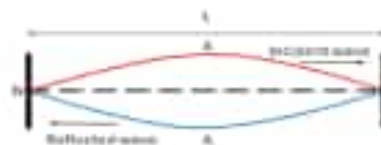

Fig: 12.10
Standing waves on a string fixed at both ends
Reflection of Waves and Phase change

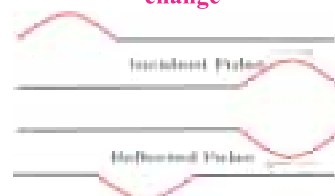

Fig: 12.10
At the interface of two different media the reflection of waves occurs. A reflected wave carrying some of the energy of the incident wave travels backward from the boundary.



Fig: 12.12
Sindhi lok musicians playing Tambora producing stationary (standing waves).

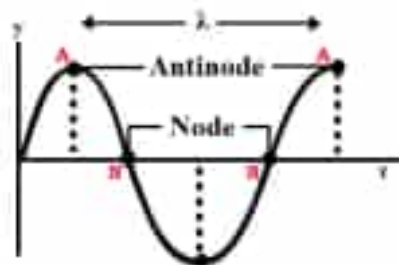

Fig: 12.13 Nodes and Antinodes on a stationary wave.

easily calculated at $x = \frac{n\lambda}{2}$. Thus the distance between two adjacent nodes is $\frac{\lambda}{2}$.

The point where displacement is maximum is called ANTI-NODE labeled as 'A'.

The points of anti-nodes occur where $\sin kx = \pm 1$, which is exactly half way between a pair of nodes. For the points of antinode $x = \frac{n\lambda}{4}$ ($n = 1, 3, 5, \dots$) So the nodes and anti-nodes alternate, with one quarter of a wavelength between a node and the neighboring antinode.

12.2.7 Modes of Vibrations in A Stretched String:

Fundamental mode of Vibration or First Harmonic:

Let a string of length L is plucked at its middle point, two transverse waves originate from this point. This superposition forms a transverse stationary wave. The whole string will vibrate in one loop, with nodes at fixed ends and anti-node at the middle as shown in the Fig.12.14. As we know that the distance between successive nodes is equal to half a wavelength λ_1 , for first harmonic wave.

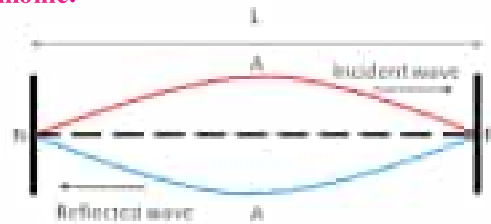

Fig: 12.14

Standing wave in its fundamental mode

$$L = \frac{\lambda_1}{2} \quad \text{or} \quad \lambda_1 = 2L \quad \dots\dots (12.15)$$

If v is the speed of either of the component progressive wave, then

$$f_1 = \frac{v}{\lambda_1} = \frac{v}{2L} \quad \dots\dots (12.16)$$

if M is the total mass of the string then the speed v of the progressive wave along the string is given by

$$v = \sqrt{\frac{TXL}{M}} \quad \text{Where } T \text{ is tension in the string} \quad \dots\dots (12.17)$$

Replacing v from Eq. 12.17 in Eq. 12.16. So the frequency f_1 is

$$f_1 = \frac{1}{2L} \sqrt{\frac{TXL}{M}} \quad \dots\dots (12.18)$$

If μ is the mass per unit length (linear density), $\mu = \frac{M}{L}$ then the above equation becomes

$$f_1 = \frac{1}{2L} \sqrt{\frac{T}{\mu}} \quad \dots\dots (12.19)$$

This characteristic f_1 of vibration is called the **fundamental frequency** or **first harmonic**.

Second mode of Vibration (Second Harmonic) or First Overtone:

If the string is now plucked from one quarter of its length then the string will vibrate in two loops. The stationary wave set up in the string will have frequency f_2 (Fig.12.15).

If λ_2 is the wavelength of second mode of vibrations

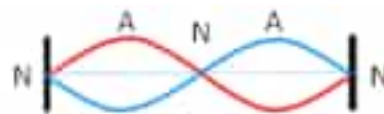

Fig: 12.15 Second harmonic or (First overtone) of vibration

$$L = \frac{\lambda_2}{2} + \frac{\lambda_2}{2} \quad \dots\dots (12.20)$$

$$\lambda_2 = \frac{2L}{2} \quad \text{or} \quad \lambda_2 = L$$

If v is the speed of either of the component of standing wave, then

$$f_2 = \frac{v}{\lambda_2} = \frac{v}{L}$$

$$f_2 = \frac{2}{2L} \sqrt{\frac{T}{\mu}} \quad \dots\dots (12.21)$$

Since; $f_1 = \frac{1}{2L} \sqrt{\frac{T}{\mu}}$

Therefore; $f_2 = 2f_1 \quad \dots\dots (12.22)$

Thus the frequency of second harmonic is twice the frequency of first harmonic.

In general when the string vibrates in n number of loops with $(n+1)^{\text{th}}$ nodes and n^{th} anti-nodes.

Third harmonic or (second overtone) of vibration:

$$L = \frac{\lambda_3}{2} + \frac{\lambda_3}{2} + \frac{\lambda_3}{2} \quad \lambda_3 = \frac{2L}{3}$$

Hence the characteristic frequency for third harmonic shall be (Fig: 12.16)

$$f_3 = \frac{v}{\lambda_3} = \frac{3v}{2L}$$

$$f_3 = \frac{3}{2L} \sqrt{\frac{T}{\mu}}$$

Or $f_3 = 3f_1 \quad \dots\dots (12.23)$

The wavelength for such a mode of vibration is

$$\lambda_n = \frac{2L}{n} \quad \dots\dots (12.24)$$

And the characteristic f_n is

$$f_n = n f_1 \quad \dots\dots (12.25)$$

Following conclusions can be made from the above discussion.

- i) A fastened string from both ends shall always vibrate in complete loops as the nodes on the end points.
- ii) The length of a loop shall be the distance between two adjacent nodes and shall be equal to half integral multiple of the wavelength.

$$L = \frac{\lambda}{2}, \frac{2\lambda}{2}, \frac{3\lambda}{2}, \dots\dots \frac{n\lambda}{2} \quad (n = 1,2,3,\dots\dots)$$
- iii) The frequency of vibration is directly proportional to the number of loops, i.e. and the corresponding wavelength is decreasing. However for any mode of vibration the product of frequency and wavelength shall remain constant.

iv) Quantization of Frequencies.

The modes of vibration of stationary waves produced in a fixed string are always in a discrete set of frequencies and shall always be the integral multiple of the frequency of fundamental mode or first harmonic of vibration. This phenomenon is called quantization.



Fig: 12.16

Self-Assessment Questions:

1. what is tuning of musical instruments? What is the importance of Beats in this process?
2. Give an expression for the velocity of a transverse wave along a thin flexible string and show that it is dimensionally correct.

12.2.8 Stationary Sound Waves (Organ Pipes):

Stationary sound waves are also caused by reflections at the boundaries. Since sound is a three dimensional wave i.e. it propagates in all direction. The air column inside a pipe open at both or one end only gives rise to standing (stationary) waves comparable to those on a string, as long as the diameter of the pipe is small compared to its length. Organ pipes and flutes are the best models to demonstrate this phenomenon.

Pipe Open at Both Ends:

If the pipe is open at both ends, then the pipe has same boundary condition at each end. At each open end, the column of air inside the pipe communicates with the outside air, so the pressure at the ends can't deviate much from atmospheric pressure. The open ends are therefore pressure nodes (Fig.12.17)

There are also displacements anti-nodes, elements of air vibrate back and forth with maximum amplitude at the ends. Since nodes and anti-nodes alternate with equal spacing ($\lambda/4$).

Hence; from equation (12.24).

$$\lambda_n = \frac{2L}{n}$$

$$n = 1, 2, 3, \dots$$

$$f_n = \frac{v}{\lambda_n} = \frac{nv}{2L}$$

$$f_n = n f_1 \quad \dots (12.26)$$

Pipe Closed at One End:

Some organ pipes are closed at one end and open at the other (Fig.12.18). The closed end is a *pressure anti-node*; the air at closed end meets a rigid boundary, so there is no limit that how far the pressure can deviate from atmospheric pressure. The closed end is also a *displacement node* since the air near it cannot move beyond that rigid surface. Some wind instruments like shehnai and clarinet are effectively pipes closed at one end.

Using displacement the fundamental mode of vibration has a **node** at close end, and **anti-node** at the open end. Since, it is mentioned earlier that the



Fig: 12.17 Standing waves in an open pipe from both ends, for First, Second and third harmonics.

The wavelength of standing waves in a open pie at both ends are the same as for a string fixed at both ends regardless of your choice of pressure or displacement description on both ends.



Fig: 12.18 Standing waves in a closed pipe at one end, for First, Second and third harmonics.

Remember that

Two thin organ pipes of the same length one open at both ends and one closed at one end do not have the same fundamental wavelength (frequency). Since, the wavelength of closed pipe is twice as large compared to open pipe at both ends, therefore a frequency half as large.

distance between a node and anti-node shall always be $\lambda/4$ for fundamental mode.

Hence;

First Harmonic:

$$L = \frac{\lambda}{4} \quad \text{or} \quad \lambda = 4L$$

which is twice as large as the wavelength ($2L$) of fundamental mode of vibration in a pipe of same length, open at both ends.

$$\text{Since; } f_1 = \frac{v}{\lambda_1} = \frac{v}{4L}$$

Second Harmonic:

If the air column vibrates for second harmonic or first overtone, then from figure.12.21

$$L = \frac{\lambda_2}{2} + \frac{\lambda_2}{4} = \frac{3\lambda_2}{4}$$

$$\text{Since; } \lambda_2 = \frac{4L}{3} \quad f_2 = \frac{3v}{4L}$$

$$\text{Or, } f_2 = 3f_1$$

Similarly for third harmonic or second overtone

$$L = \frac{5\lambda_3}{4}$$

$$\text{And } \lambda_3 = \frac{4L}{5}$$

$$\text{and } f_3 = 5f_1$$

Note that the standing wave frequencies for closed pipe at one end are odd integral multiple of the fundamental frequency.

$$f_n = \frac{v}{\lambda_n} = \frac{nv}{4L} = nf_1 \quad n = (1, 3, 5, \dots) \quad \dots (12.27)$$

Self-Assessment Questions:

1. A pipe has a length of 2.46 m (a) Determine the frequency of first harmonic and the first two overtones, if the pipe is open at both ends, take $v = 344 \text{ ms}^{-1}$. Determine the frequencies of fundamental mode and first two overtones for closed pipe.
2. Is the vibration of a string in a piano, guitar, or violin a sound wave? Explain.

12.3 Doppler Effect of Sound:

The Doppler effect is a phenomenon in physics that describes the perceived change in frequency of a wave (such as sound or light) when the source of the wave or the observer is in relative motion. It is named after the Austrian physicist Christian Doppler, who first described it in 1842.

In the case of sound waves, the Doppler effect occurs when there is relative motion between the source of the sound and the observer. The key characteristic of the Doppler effect is that the frequency of the sound waves appears higher (or lower) to the observer depending on the direction of motion.

The Doppler effect can be observed in everyday situations, such as when a vehicle with a siren passes by. As the vehicle approaches, the sound of the

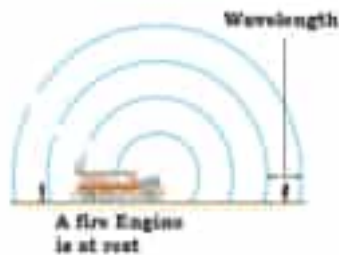

Fig: 12.19

When the fire engine is at rest the wavelength of the sound is the same in front of and behind the truck and then frequency heard by the listener is. $f = v/\lambda$

siren is heard at a higher pitch (higher frequency) than its actual source frequency. When the vehicle moves away, the sound of the siren is heard at a lower pitch (lower frequency) than its actual source frequency.

12.3.1 Change in Observed Frequency due to the Relative Motion of Source or Listener or Both:

A source emits a sound wave at frequency f , with velocity v and wavelength λ which means that wave crests (regions of maximum amplitude, indicated by circles in (Fig. 12.20) leave the source spaced by a time interval

$$T = 1/f.$$

Moving Source:

Source is moving towards the observer at rest:

If the source is moving at velocity v_s *toward a stationary observer* on the right, figure.12.20 shows that the wavelength, the distance between the crests is smaller to the right. Figure.12.20 (b) shows that at the instant that crest 4 is emitted, crest 3 has travelled outward a distance vT_s from point 3. During the same time interval, the source has advanced a distance v_sT_s . The wavelength λ' as measured by the observer on the right is the distance between crests 4 and 3:

$$\lambda' = vT_s - v_sT_s$$

The frequency at which the crests arrive at the observer is the observed wave frequency f' . The observed time period T' between the arrival of two crests is the time it takes sound to travel a distance $(v-v_s)T_s$:

$$T' = \frac{(v-v_s)T_s}{v}$$

The observed frequency is $f' = \frac{1}{T'} = \frac{v}{(v-v_s)} \times \frac{1}{T_s}$

Dividing numerator and denominator by v and substituting $f_s = \frac{1}{T_s}$ yields

$$f' = \left(\frac{v}{v-v_s}\right) \times f_s \quad \dots\dots (12.28)$$

This shows that the observed frequency is higher than the source frequency, when the source moves in the same direction as the wave towards the observer.

Source is moving away from the observer at rest:

If the source is moving at velocity v_s *away from the stationary observer* on the left, then according to figure.12.20, the wavelength, the distance between the crests is larger to the left. The wavelength λ' as measured by the observer on the left in (Fig.12.20) is the distance between crests 3 and 4:

$$\lambda' = vT_s + v_sT_s$$

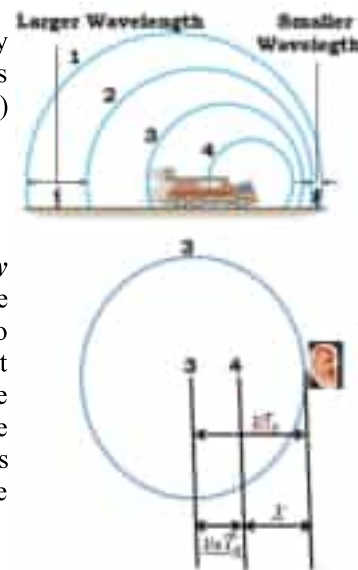

Fig: 12.20 (a) A Fire engine is moving to the right at speed v_s while it blows its siren. The siren emits wave crests at position 1, 2, 3 and 4. Each wave crest moves outward in all directions, from the point at which it was emitted, at speed v . (b) The observed wavelength λ' is the distance between the wave crests.

Hence; the observed frequency by the stationary listener shall be less than the source frequency, given as

$$f' = \left(\frac{v}{v+v_s}\right) \times f_s \quad \dots\dots (12.29)$$

Moving Observer:

Observer is moving towards the source at rest:

A stationary source emits a sound wave at frequency f_s and wavelength $\lambda_s = v/f_s$, where v is the speed of sound. An observer moving towards the stationary source with speed v_o would observe a shorter time interval between crests. Just as crest 1 reaches the observer, the next crest 2 is at distance λ_s ahead. Crest 2 catches up with the observer with time T' earlier than the time T_s , when the distance vT' the wave crest 2 travels toward the observer is equal to wavelength of sound minus the distance the observer travels towards the wave crest 2 as shown in figure 12.21.

$$\begin{aligned} vT' &= \lambda_s - v_oT' \\ \lambda_s &= vT' + v_oT' \\ \lambda_s &= (v + v_o)T' \quad \dots\dots (12.30) \end{aligned}$$

Given that $f' = \frac{1}{T'}$ and $\lambda_s = v/f_s$ replacing T' and λ_s in equation 12.31

$$f' = \left(\frac{v+v_o}{v}\right) f_s \quad \dots\dots (12.31)$$

Observer is moving away from the source at rest:

Now consider an observer moving away from the source at velocity v_o . He observes a longer time interval between crests. Just as crest 1 reaches the observer, the next crest 2 is a distance λ_s away. Crest 2 catches up with the observer at a time T' later when the distance the wave crest travels toward the observer is equal to the distance the observer travels away from the wave crest plus the wavelength (Fig.12.22)

$$\begin{aligned} vT' &= v_oT' + \lambda_s \\ \text{or} \\ (v - v_o)T' &= \lambda_s \\ (v - v_o)T' &= v/f_s \\ f' &= \left(\frac{v-v_o}{v}\right)f_s \quad \dots\dots (12.32) \end{aligned}$$

An observer moving away from the source detect a frequency lower than the f_s .

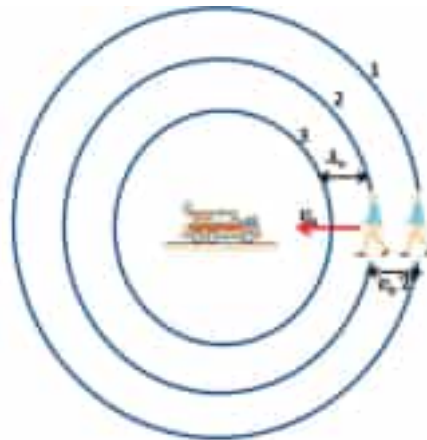

Fig: 12.21

An observer is moving towards the stationary source with speed v_o . The observed frequency shall be greater than the source frequency.

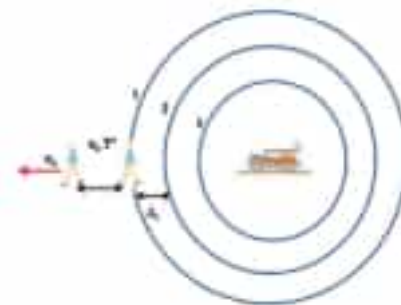

Fig: 12.22

An observer is moving away from the stationary source with speed v_o . The observed frequency shall be lower than the source frequency.

Motion of Both Source and Observer:

Since the relative change in the frequency (pitch) of sound with respect to listener is dependent upon the motion of source of sound or listener.

If the **source and listener both moves towards each other** then we combine the two Doppler's shifts. First consider the relative change in frequency with respect to stationary listener as the source is approaching towards the listener. Let f_L be the frequency detected by the listener.

$$f_L = \left(\frac{v}{v-v_s}\right) f_s \quad \dots\dots (12.33)$$

If at some moment the listener starts moving towards the approaching source with velocity v_o , then the detected frequency f_o shall be

$$f_o = \left(\frac{v+v_o}{v}\right) f_L \quad \dots\dots (12.34)$$

Substituting the value of f_L yields

$$f_o = \left(\frac{v+v_o}{v-v_s}\right) f_s \quad \dots\dots (12.35)$$

In case the **source and listener are moving away from each other** then the observed frequency shall be

$$f_o = \left(\frac{v-v_o}{v+v_s}\right) f_s \quad \dots\dots (12.36)$$

Worked Example 12.3

A source of sound and listener are moving towards each other with velocities which are 0.5 times and 0.2 times the speed of sound respectively. If the frequency of emitting sound is 2000 Hz, calculate the percentage change in the frequency with respect to the listener.

Solution:

Step 1: Write the known quantities and point out the quantities to be found.

Speed of source; $v_s = 0.5v$

Speed of listener; $v_o = 0.2v$

$f = 400\text{Hz}$

Required: $f_o = ?$

Step 2: Write the formula and rearrange if necessary. $f_o = \left(\frac{v+v_o}{v-v_s}\right) f_s$

Step 3: Put the values in the formula and calculate.

$$f_o = \left(\frac{v+0.2v}{v-0.5v}\right) \times 2000 \text{ taking } v \text{ common}$$

$$f_o = \left(\frac{1.2}{0.5}\right) \times 2000 = \mathbf{4800 \text{ Hz}}$$

$$\text{Percentage in Frequency} = \left(\frac{f_o - f_s}{f_s}\right) \times 100\% = \left(\frac{4800 - 2000}{2000}\right) \times 100\% = \mathbf{140\%}$$

Shock Waves:

For a plane moving slower than sound, the wave crests in front of it are closer together due to the plane's motion. An observer to the right would measure the frequency increases. (Fig.12.24a)

For a plane moving at the speed of sound the wave crests pile up on top of each other; they move to the right at the same speed as the plane, so they can't get ahead of it. The wall of high pressure air is called sound barrier. An observer to the right would measure the wavelength of zero-zero distance between waves crests therefore and infinite frequency. (Fig.12.24b)

If the source moves at the speed greater than the speed of sound, figure 12.24 c shows that the wave crests pile on top of one another to form cone-shaped shock waves, which travel outward in the direction indicated. There are two principal shock waves formed, one starting at the nose of the plane and one at the tail. The sound of the shock is referred to the Sonic boom.



Fig: 12.23
A fighter plane breaking the sound barrier

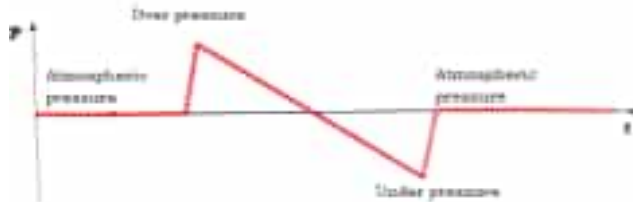

Fig: 12.25
The variation in pressure at a point on the ground as a supersonic plane flies overhead.

The pressure variation shown in Fig 12.25 is the sonic boom caused by the air plane flying at the constant velocity greater than the speed of the sound. The variation is called the N-shaped (because the pressure graph is shaped like the letter N).

12.3.2 Applications of Doppler:

Echolocation is a valuable navigation tool for various life forms on our planet. While oil birds and cave swiftlets use audible sound waves for echolocation (detectable by humans), dolphins, whales, and most bats utilize ultrasound (20 Hz to 200 KHz) instead.

Bats and dolphins gain an advantage by sensing the Doppler shift between emitted and reflected waves,

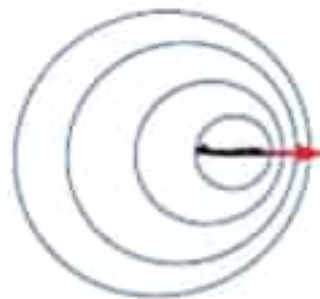

Fig: 12.24 (a)

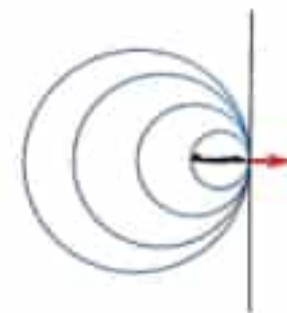

Fig: 12.24 (b)

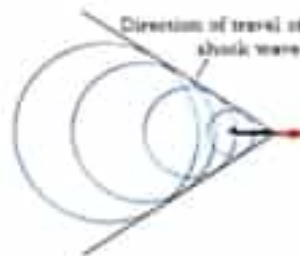

Fig: 12.24 (c)

allowing them to locate and track fast-moving prey effectively.

The Doppler Effect for light is vital in ASTRONOMY. Analyzing light emitted by elements in distant stars reveals wavelength shifts compared to the same element's light on Earth. These shifts, known as red shifts, indicate motion of the stars. Redshift observations have provided evidence for expanding universe cosmological theories, suggesting the universe evolved from a great explosion billions of years ago in a relatively small region of space.

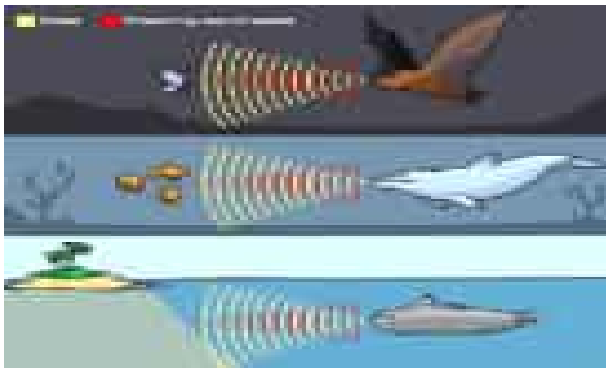

Fig: 12.26

The use of Doppler effect by Bat, Dolphin and a submarine for echolocation.

SONAR devices emit ultrasonic pulses (Fig.12.27) to determine distances. The time delay between pulse emission and reflection helps measure seafloor distance. For low-range submarine detection, the Navy uses low-frequency active (LFA) sonar with audible sound (100 to 500 Hz) instead of ultrasonic. Air guns use to study the earth's interior structure and locate oil underground.

VOR (Very High Frequency Omnidirectional Range) is a guiding system at airports that directs incoming aircraft to the airport's location. Modern airports like Quaid-e-Azam International Airport Karachi and Islamabad Airport use Doppler VOR systems (Fig: 12.28). The electromagnetic signal used operates in the VHF range (30 MHz-300MHz).

RADARS (Radio Detection and Ranging) serve civil and military purposes at airports and air bases, detecting aircraft presence by evaluating range. Doppler radar,

DO YOU KNOW?

The speed of the supersonic plane is often given as **Mach Number**, name for Austrian Physicist **Ernst Mach** (1838-1916).

The Mach number is the ratio of the speed of the plane to the speed of sound.

A plane flying at Mach 3.3 where the air temperature is 11° C is moving at $3.3 \times 338 \text{ m/s} = 1100 \text{ m/s}$ with respect to the air. The Pressure variation for the Concorde is 93Pa above and below the atmospheric pressure at a speed of Mach 2 and at a height 15.8 km; the noise level heard from the Concorde's boom is usually 120 dB directly under flight path.



Fig: 12.27 A ship with a sonar device to locate the depth of the seafloor.



Fig: 12.28 A VOR system installed at airport maintain a highly reliable, safe, and efficient ground-based navigation system.

based on the Doppler Effect, is used to determine aircraft speed and direction. It is also crucial in weather forecasting, showing storm location and wind velocity.

RADAR SPEED TRAPS or Speed (Radar) guns use by traffic police to measure the speed of an automobile or use in Cricket matches the measure the speed of a ball deliver by the bowler. A reflected electromagnetic signal is received from the automobile by the radar gun



Fig: 12.29
A radar system and a radar trap

12.3.3 Doppler's Effect and Cardiovascular Problems:

Ultrasound is also used to examine organs such as heart, liver, gallbladder, kidneys, breasts and eyes, and to locate tumors. It can be used to diagnose various heart conditions and to assess damage after a heart attack. Ultrasound can show movements, so it is used to assess heart valve function and to monitor blood flow in large blood vessels. Since, ultrasound provides real-time images. It is sometimes used to guide procedures such as biopsies, in which a needle is used to take a sample from an organ or tumor for testing.

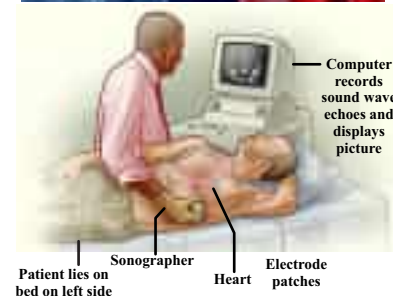
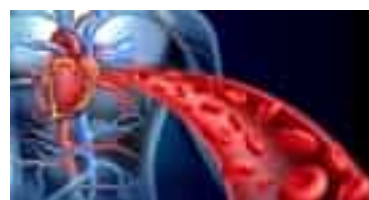

Fig: 12.30 Ultrasound examination of Heart. The computer image is called **echocardiogram**.

Doppler ultrasound is a newer technique that is used to examine blood flow. It can help reveal blockage to blood flow, show the formation of plaque in arteries, and provide detail information on the heartbeat of the patient. In ultrasonic imaging, ultrasound waves ($> 20,000$ Hz) rather than sound waves of of audible frequencies (20Hz to 20,000Hz) are used. Waves with small wavelengths diffract less around the same obstacle than do waves with larger wavelengths. The frequencies used in imaging are typically in the range of 1 to 15 MHz, which means that the wavelengths in human tissue are in the range of 0.1 to 1.5 mm. As a comparison if sound waves at 15 KHz were used, the wavelength inside the body would be 10 cm. Higher frequencies give better resolution but at expense of less penetration; sound waves are absorbed within a distance of 500λ in tissue.

Self-Assessment Question:

1. The source and observer of a sound wave are both at rest with respect to ground. The wind blows in the direction from source to observer. Is the observed frequency Doppler shifted? Explain.

DO YOU KNOW?

Why are sound waves used rather than electromagnetic waves like X-rays?

X-rays are damaging to tissue, especially to rapidly growing fetal tissue. After decades of use, ultrasound has no known adverse effects.



SUMMARY

- A sound wave can be described either by gauge pressure p , which means the pressure fluctuation above, and below the ambient atmospheric pressure, or by displacement s on each point in the medium from its un-displaced position.
- Humans with excellent hearing can hear frequencies from 20 Hz to 20 KHz. The term infrasound and ultrasound are used to describe sound waves with frequencies below 20Hz and above 20 KHz respectively.
- The speed of sound in a fluid is $v = \sqrt{\frac{B}{\rho}}$.
- The speed of sound in an ideal gas at any absolute temperature T can be found if is known at one temperature: $v = v_0 \sqrt{\frac{T}{T_0}}$, where the speed of sound at absolute temperature T_0 is v_0 .
- The speed of sound in air at 0°C or 273 K is 332 m/s.
- For sound waves travelling along the length of the thin solid rod, the speed is approximately $v = \sqrt{\frac{Y}{\rho}}$ (thin solid rod).
- In a standing sound wave in a thin pipe, an open end is the pressure node and the displacement anti-node; a closed end is the pressure anti-node and a displacement node.
- The principle of superposition; when two or more waves overlap, the net disturbance at any point is the sum of the individual disturbances due to each wave.
- A harmonic travelling wave can be described by $y(x,t) = A \sin(kx - \omega t)$.
- For a pipe open at both ends, $\lambda_n = \frac{2L}{n}$, $f_n = \frac{nv}{2L} = nf_1$, where $n = 1, 2, 3, \dots$
- For a pipe closed at one end, $\lambda_n = \frac{4L}{n}$, $f_n = \frac{nv}{4L} = nf_1$ where $n = 1, 3, \dots$
- When two sound waves are closed in frequency the superposition of the two produces a pulsation called beats. $f_{\text{beats}} = \Delta f$.
- Doppler Effect, if v_s and v_o are the velocities of the source and the observer, the observed frequency is $f_o = \left(\frac{1 + \frac{v_o}{v}}{1 \mp \frac{v_s}{v}} \right) f_s$.

where v_s and v_o are positive in the direction of the propagation of the wave and the wave medium is at rest.

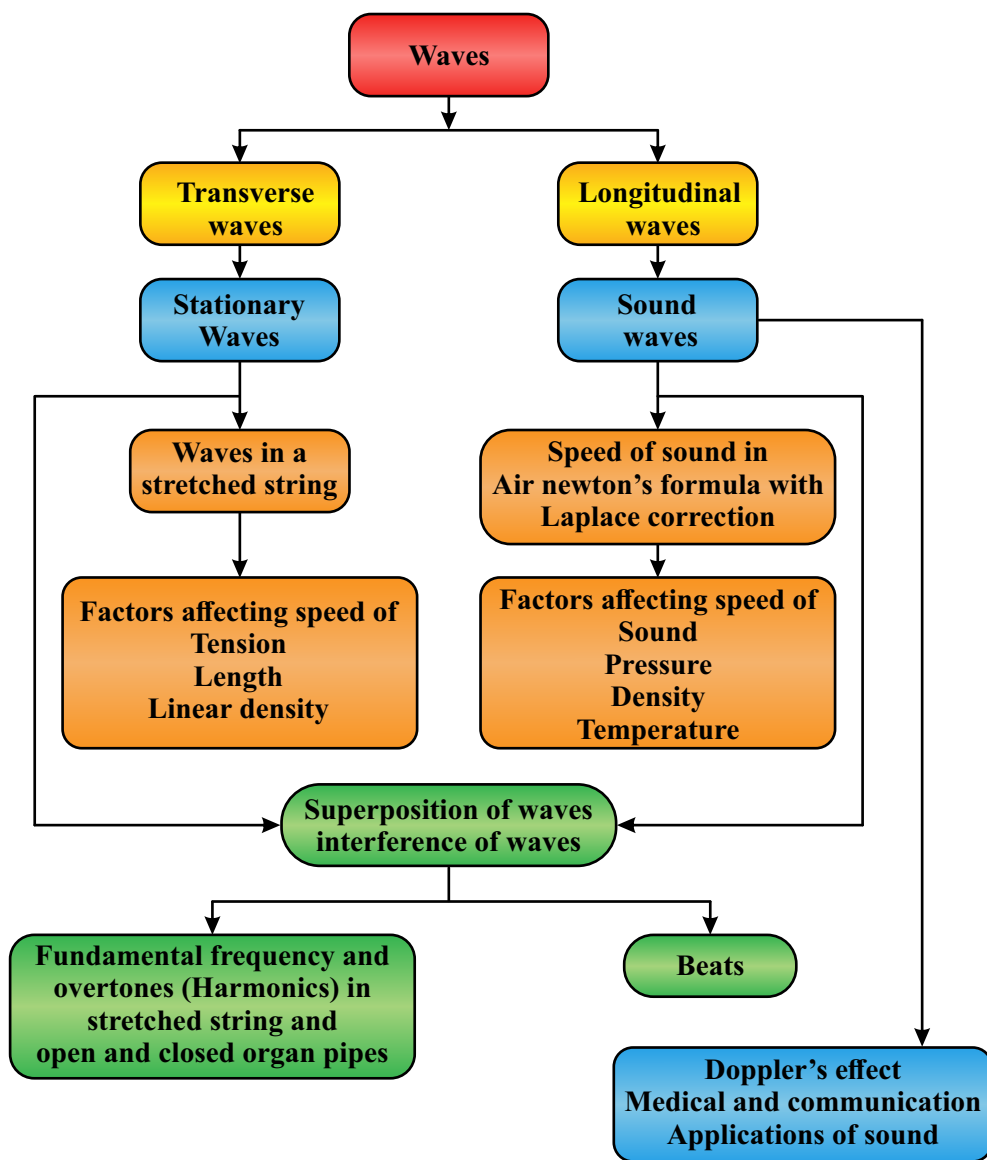



Section (A): Multiple Choice Questions (MCQs)

- The speed v of a wave represented by $y = A \sin(\omega t - kx)$ is:
a) k/ω b) ω/k c) ωk d) $1/\omega k$
- Two sound waves are $y = A \sin(\omega t - kx)$ and $y = A \cos(\omega t - kx)$. The phase difference between the two waves is:
a) $\pi/2$ b) $\pi/4$ c) π d) 0
- If v_a , v_h and v_m are the speeds of sound in air, hydrogen gas, and a metal at the same temperature, then:
a) $v_a > v_h > v_m$ b) $v_m > v_h > v_a$ c) $v_h > v_m > v_a$ d) $v_h > v_a > v_m$
- The speed of sound in air at STP is 332 m/s. If the air pressure becomes double at the same temperature, the speed of sound become:
a) 1382 m/s b) 664 m/s c) 332 m/s d) 166 m/s
- How does the speed of sound v in air depend on the atmospheric pressure P :
a) $v \propto P^0$ b) $v \propto P^{-1}$ c) $v \propto P^2$ d) $v \propto P^1$
- The speed of sound in a gas is proportional to:
a) square root of isothermal elasticity b) square root of adiabatic elasticity
c) isothermal elasticity d) adiabatic elasticity
- The length of a pipe closed at one end is L . In the standing wave whose frequency is 7 times the fundamental frequency, what is the closest distance between nodes?
a) $\frac{1}{14} L$ b) $\frac{1}{7} L$ c) $\frac{2}{7} L$ d) $\frac{4}{7} L$
- A 620 Hz frequency song of a ice cream trolley approaches with speed v to a boy standing at the door of his house is heard with frequency f_1 . If the trolley is stopped and the boy approaches to the ice cream trolley with same speed v ; the boy now hears the sound with frequency f_2 . choose the correct statement:
a) $f_1 = f_2$; both are greater than 620Hz b) $f_2 > f_1 > 620\text{Hz}$
c) $f_1 = f_2$; both are lesser than 620Hz d) $f_1 > f_2 > 620\text{Hz}$.
- The speed of sound in a gas in which two waves of wavelength 50 cm and 50.4 cm produce 6 beats per second is:
a) 338 m/s b) 350 m/s c) 378 m/s d) 400 m/s
- The speed of a wave in a medium is 760 m/s. If 3600 waves are passing through a point in the medium in 2 minutes, then its wave length is:
a) 13.85 m b) 25.3 m c) 41.5 m d) 57.2 m

CRQs

1. Why sound can not travel through vacuum.
2. On what factors speed of sound depends on
3. What are the conditions for the interference of waves
4. Is the energy of a wave is maximum or minimum at nodes?
5. Why is it possible to understand the words spoken by two people at the same time?

ERQs:

1. Define a sound wave and explain its nature as a longitudinal wave. Discuss the key properties of sound waves, such as frequency, wavelength, amplitude, and speed of propagation
2. Discuss the concept of the Doppler Effect in sound waves. Explain how the motion of a source or observer affects the perceived frequency and pitch of a sound wave. Provide examples to illustrate the Doppler Effect in daily life.
3. What is standing wave? How they are produced? Also elaborate the concept of nodes and antinodes in standing waves. Explain their locations and the relationship between node spacing and wavelength.
4. Define the Doppler Effect and Derive the Doppler Effect equation for sound waves in terms of the relative velocity between the source, observer, and the speed of sound.
5. Define standing waves and explain how they are formed.
6. Discuss the concept of harmonics in standing waves. Explain how harmonics are formed and their relationship with the fundamental frequency.

Numericals:

1. The equation of a wave is $y(x, t) = 3.5 \sin \left\{ \frac{\pi}{3.0}x - 66t \right\}$ cm where t is in seconds and x and y both are in cm. Find (a) the amplitude and (b) the wavelength of this wave.
(a) 3.5 cm (b) 6.0 cm
2. Why is it that your own voice sounds strange to you when you hear it played back on a tape recorder, but your friends all agree that it is just what your voice sounds like?
3. Why the speed of sound in solids is much faster than the speed of sound in air?
4. An increase in pressure of 100 k Pa causes a certain volume of water to decrease by 5×10^{-3} percent of its original volume. Find (a) Bulk modulus of water. (b) What is the speed of sound in water?
(a) 2000 MPa (b) 1400 ms⁻¹
5. A uniform string of length 10.0 m and weight 0.25 N is attached to the ceiling. A weight of 1.00 kN hangs from its lower end. The lower end of the string is suddenly displaced horizontally. How long does it take the resulting wave pulse to travel to upper end? Neglect the weight of string in comparison to hanging mass). **(16 ms approx)**
6. A travelling sine wave is the result of the superposition of two other sine waves with equal amplitudes, wavelengths, and frequencies. The two component waves each have amplitude 5.00 cm. if the resultant wave has amplitude 6.69, what is the phase difference ϕ between the component waves?
(96°)

7. In order to decrease the fundamental frequency of a guitar string by 4.0%, by what percentage should you reduce the tension? **(76.96%)**
8. A string 2.0 m long is held fixed at both ends. If a sharp blow is applied to the string at its centre, it takes 0.050 s for the pulse to travel to both ends of the string and return to the middle. What is the fundamental frequency of oscillation for this string? **(10Hz)**
9. A sound source of frequency f_0 and an observer are located at a fixed distance apart. Both the source and observer are at rest. However, the propagation medium (through which the sound waves travel at speed v) is moving at a uniform velocity v_m in an arbitrary direction. Find the frequency detected by the observer giving physical explanation.
10. A train sounds its whistle while passing by a railroad crossing. An observer at the crossing measures a frequency of 219 Hz as the train approaches the crossing and a frequency of 184 Hz as the train leaves. The speed of the sound is 340ms^{-1} . Find the speed of the train and frequency of its whistle. **$v_T = 29.5\text{ ms}^{-1}$ $f_0 = 200\text{ Hz}$**



On earth the shimmering colors of butterflies and beetles and the beautiful color of a peacock dancing in THAR is due to some phenomenon exhibited by light. To understand the Universe the most important tool is light (electromagnetic radiations).

In this unit student should be able to:

- Understand electromagnetic spectrum (ranging from radio waves to γ rays).
- Recall that light is a part of continuous spectrum of electromagnetic waves.
- Describe the concept of wave fronts and its types.
- State Huygens's principle and use it to construct wave front after a time interval
- State the necessary conditions to observe interference of light.
- Describe Young's double slit experiment and the evidence it provides to support the wave theory of light.
- Use the equations of constructive and destructive interference to determine the position of bright and dark fringes also determine the fringe spacing.
- Explain color pattern due to interference in thin films.
- Describe interference pattern produced by Newton's rings.
- Describe the parts and working of Michelson Interferometer and its uses.
- Explain diffraction and identify that interference occurs between waves that have been diffracted.
- Describe that diffraction of light is evidence that light behaves like waves.
- Describe and explain diffraction at a narrow slit.
- Describe the use of a diffraction grating to determine the wavelength of light and Carry out calculation using $d\sin\theta = n\lambda$.
- Describe the phenomenon of diffraction of X-rays through crystals.
- Measure the slit separation /grating element 'd' of a diffracting grating by using the known wavelength of laser light.

The study of light has been a significant aspect of science since ancient times, with contributions from the Greeks and Islamic scholars. The scientific revolutions of the 16th and 17th centuries, led by Newton, Huygens, Young, Maxwell, and Einstein, expanded the field into what we now call OPTICS.

In secondary classes, we learned about Geometric Optics focusing on reflection and refraction through mirrors, glasses, and lenses. Geometric optics assumes light propagates in straight lines, changing direction through reflection or refraction at different surfaces.

Moving to Physical Optics, we emphasize the wave nature of light. Here, we explore light's behavior around obstacles or small apertures compared to the wavelength. This leads to phenomena like interference, diffraction, and polarization as light transmits through different media.

13.1 Nature of Light:

Light is a captivating phenomenon, described as electromagnetic radiation, with dual characteristics as both particles (photons) and waves. This wave-particle duality is fundamental to its behavior, allowing it to propagate through space, exhibit interference, diffraction, and polarization as a wave, while interacting with matter as quantized packets of energy. Light's constant speed in a vacuum, approximately three lac kilometers per second ($3 \times 10^8 \text{ m/s}$), is a universal constant. Its interactions with matter lead to various phenomena, like reflection, refraction, and absorption. Understanding light has enriched our knowledge of the cosmos and revolutionized technologies in communication, imaging, and scientific research.

13.1.1 Electromagnetic Spectrum:

The longitudinal mechanical waves like sound waves are propagated through a medium due to the vibrations of massive particles (atom or molecules).

Electromagnetic waves are transverse waves, as the name depicts these waves possess both electric and magnetic properties.

We know that a static point charge gives rise to an electric field only. Similarly, a charge moving at constant velocity produces both electric and magnetic fields. But,

When a charge particle accelerates, it produces electromagnetic waves.

Oscillations of electric charges due to an ac current in an *electric dipole* antenna, (Fig.13.1) or transitions

DO YOU KNOW?

Electromagnetic waves from radio waves to gamma rays all travel with same speed ($c = \nu\lambda$) of $3 \times 10^8 \text{ m/s}$ in vacuum. The speed of visible light was first measured by **Armand Hippolyte Louis Fizeau** in 1849, with the help of toothed wheel apparatus.

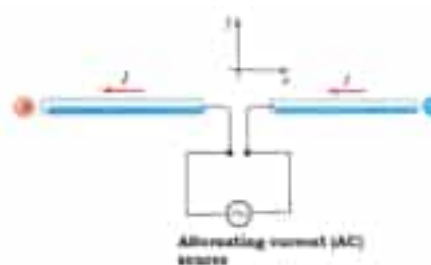
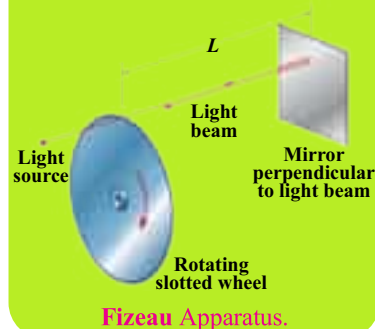

Fig: 13.1
Current in an electric dipole antenna

of electrons in an atom from a higher to lower energy level are also some sources of electromagnetic waves. In both examples mentioned above the back and forth movement of charges (Fig.13.2) with a certain frequency produces electric and magnetic fields at the same frequency. According to Faraday's laws of electromagnetic induction a time varying magnetic field induces an electric field. Likewise a Scottish physicist James Clerk Maxwell (1831-1879) showed that a changing electric field does give rise to a magnetic field.

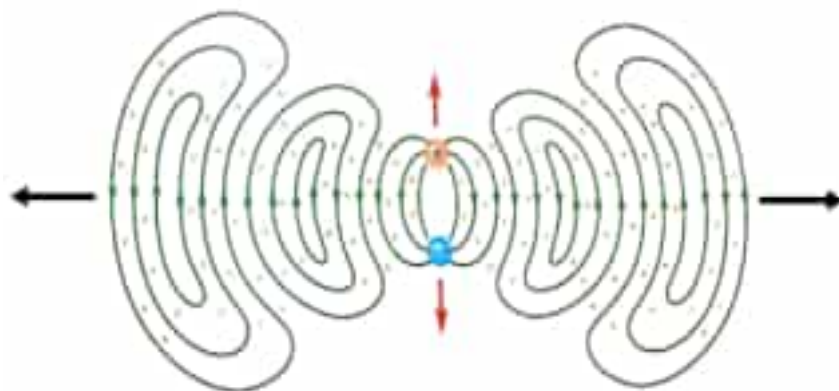

Fig: 13.2

The loops are electric field lines parallel to the plane of page. The dots and crosses are magnetic line of force perpendicular to the plane of page.

The interaction of these time varying electric and magnetic fields produces electromagnetic waves which move away from the source with speed of light (Fig.13.3). With the help of Gauss's law and Ampere's law, Maxwell successfully proved the speed of light can travel in vacuum given as

$$c = \frac{1}{\sqrt{\epsilon_0 \mu_0}} = 3.00 \times 10^8 \text{ m/s.}$$

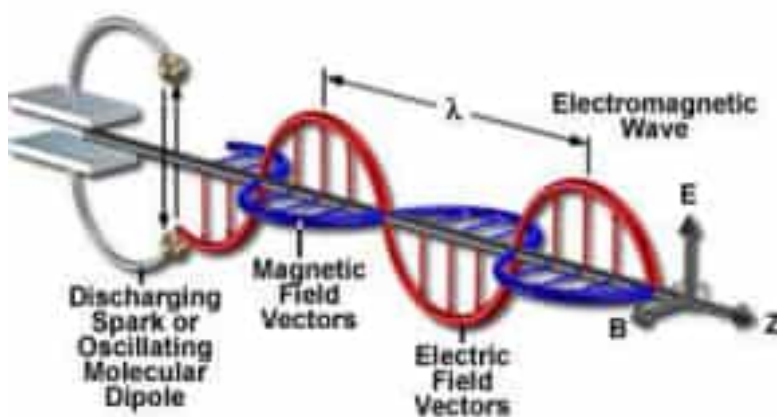

Fig: 13.3 Propagation of electromagnetic waves.

The *electromagnetic spectrum* as shown in fig. 13.4 is the broad range of frequencies and wavelengths of electromagnetic waves.

Characteristically electromagnetic spectrum is classified in seven regions from Radio waves to Gamma rays. The boundaries between the regions are somewhat indistinct and arbitrary.

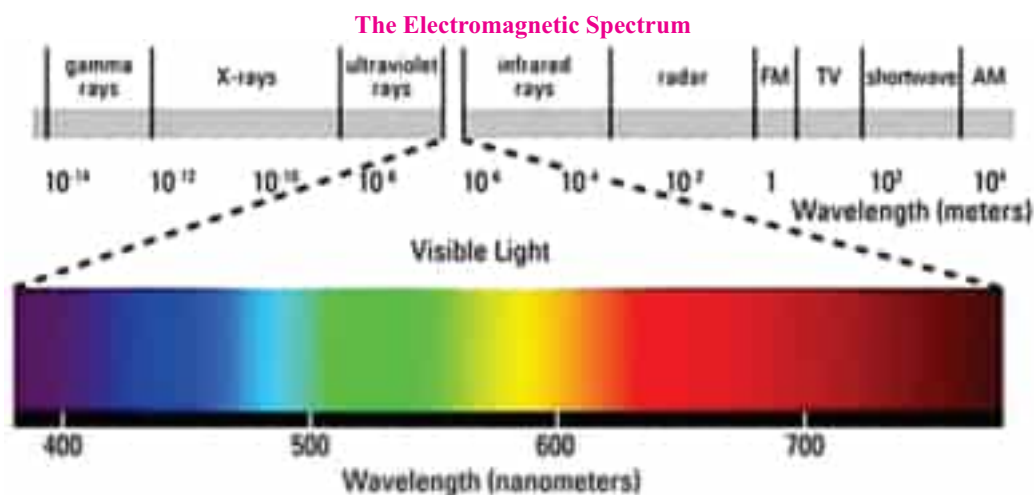

Fig: 13.4 Regions of Electromagnetic Spectrum

Radio waves:

Radio waves were discovered in 1887 by **Heinrich Hertz** a professor of physics in Karlsruhe, Germany. In 1932 **Karl Guthe Jansky** concluded that the source of persistent radio waves came from the centre of our galaxy. These waves are also generated by oscillation of electric charges.

The wavelength range of radio waves is typically of the order of 0.1m to 3×10^4 m approximately.

Nowadays radio frequencies are crowded with signals from radio and TV stations as well as gathering information from Universe.

Microwaves:

The wavelength range of microwaves are typically (0.3 m) to (30 cm) in free space.

In 1960, Arno Penzias and Robert Wilson are troubled with their radio telescope due to the noise in the microwave part of their spectrum.

The investigations to set right of this problem led to discover that the entire



Fig: 13.5 The Lovell Telescope at Jodrell Bank located at Cheshire near Manchester (United Kingdom).

universe is immersed in microwaves, remains of cosmic microwave background radiations leftover after **Big Bang**, the origin of the universe. Significant information about our own and other galaxies are obtained by the microwaves (1420 MHz \sim 21cm) emitted by neutral hydrogen atoms distributed over a vast region of space.

Infrared:

The prefix infra means below.

The frequency of infrared radiation extends from low frequency of red edge of visible light to a frequency of 300 GHz with corresponding wavelength of 1mm.

Infrared radiations were discovered in 1880 by a German born British astronomer (1738-1822) Frederick William Herschel while studying the temperature rise due to the light coming out of a prism. Although the peak of Sun's radiation is in the visible, however about half the energy reaching us from the Sun is infrared. Infrared Astronomy satellites make use of this to survey the sky as well as of earth.

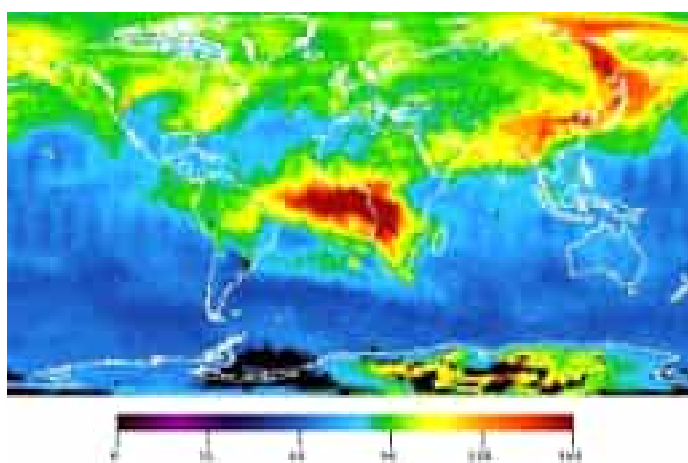
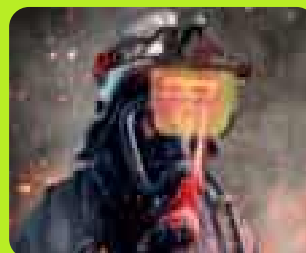

Fig: 13.6
An image of Earth in infrared wavelengths shows relative temperatures in **Fahrenheit** around the world.

DO YOU KNOW?



Infrared penetrates smoke and dust well than visible light so infrared detectors are used by rescue services like fire brigade and by armed forces to make attacks under cover of a smoke screen.

DO YOU KNOW?

Rattlesnakes and other pit vipers have infrared detectors on their snouts containing protein channels that are activated by heat from the bodies of their prey. This helps them to detect warm blooded prey. At night, the pit organs allow snakes to 'see' an image of their predator or prey like an infrared camera.



Ultraviolet:

Ultraviolet radiation has higher frequencies than visible light, with wavelengths ranging from 380 nm to 10 nm. The sun is the primary source of UV radiation. UV radiation affects human skin by causing tanning, sunburn, and melanoma. Water vapor transmits much of the Sun's UV radiation, leading to tanning and sunburn even on overcast days. Glass absorbs most UV, preventing tanning through windows. Fluorescent materials can absorb UV and emit visible light, as seen in fluorescent lights.



Fig: 13.7
A sunburn victim due to UV radiations

X – Rays:

X-rays are high-frequency, short-wavelength electromagnetic radiations discovered by Wilhelm Conrad Rontgen in 1895. They have frequencies from approximately 2.4×10^{16} Hz to 5×10^{19} Hz. In medicine and dentistry, X-rays with wavelengths of 10 pm to 60 pm are commonly used. Conventional X-rays use film to record the amount of X-ray radiation passing through tissues..

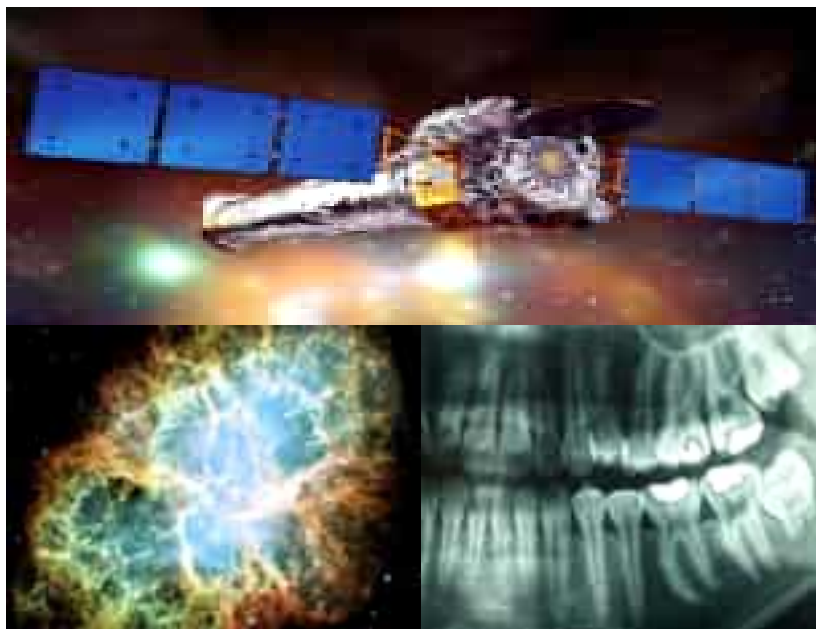

Fig: 13.8 (a, b)
Orbiting X-ray Telescope and X-ray of Teeth

Orbiting X-ray telescopes have given us an exciting new picture of the Universe. An optical image of the Crab Nebula from a X-Ray telescope.

Gamma – Rays:

Gamma rays are high-frequency, short-wavelength electromagnetic radiations emitted during atomic nucleus transitions. They originate from pulsars, neutron stars, black holes, and supernova explosions. Fortunately, the Earth's atmosphere absorbs gamma rays, requiring high-altitude sensors for detection. Gamma-ray bursts occur daily from deep space, lasting from a fraction of a second to a few minutes. These bursts release more energy in seconds than the sun does in its entire lifetime.

13.1.2 Visible Light and Continuous Spectrum:

When we speak of light (**visible light**), we mean the small fraction of electromagnetic continuous spectrum that can be seen by unaided human eye. At an average the range of frequencies are from 400 THz to 750 THz ($T = \text{tera} = 10^{12}$) corresponding to wavelength in vacuum of 750 nm to 400 nm.

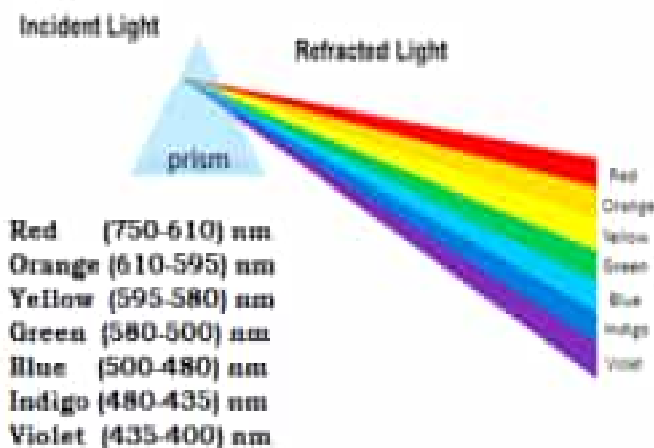

Fig: 13.9
Dispersion of white light through a prism.

White light is a mixture of all the wavelengths in the visible range. White light can be dispersed through a prism into different colors.

Red has the lowest frequency (longest wavelength) and violet has the higher frequency (shortest wavelength). Light bulbs, fire, the Sun, and fireflies are some sources of visible light.

DO YOU KNOW?



Each of the colors on the sails of these boats corresponds to a different wavelength in the visible region of the spectrum of electromagnetic waves.

DO YOU KNOW?



Light production in fireflies is due to a type of chemical reaction, called bioluminescence. This process occurs in specialized light-emitting organs, usually on a firefly's lower abdomen. The enzyme luciferase acts on the luciferin, in the presence of magnesium ions, ATP (**adenosine triphosphate**), and oxygen to produce light.

Self-Assessment Questions:

- Name the type of electromagnetic radiations corresponding to each of the given wavelengths,
 a) 500 nm b) 10000 Km c) 1 cm
- State two main properties of electromagnetic waves.

13.2 Wave fronts:

Although electromagnetic waves are different from mechanical waves (sound waves, water waves) but still these waves share many properties in common with all other waves. We can use other waves to understand the behavior of electromagnetic waves. A pebble dropped into a pond starts a disturbance that propagates radially outward in all directions on the surface of water (Fig.13.10).

A wave front is a set of all points of equal phase. Each of circular wave crests in figure.13.18 can be considered as wave front.



Fig.13.10
Spherical waves produce in water

A ray points in the direction of propagation of a wave and is perpendicular to the wave fronts. For a circular wave, the rays are radii pointing outward from the point of origin of the wave. For a linear wave, the rays are a set of lines parallel to each other, perpendicular to the wavefronts. Like water waves, light waves which propagate in three dimensions can have wavefronts that are circles or lines.

If a point source S emits light equally in all directions, the wavefronts are spherical

(fig.13.11a) and light rays point radially outward. Far away from such a point source, the rays are nearly parallel to each other and the wavefronts are nearly **planar** (fig.13.11b). So the waves can be considered as plane wave.

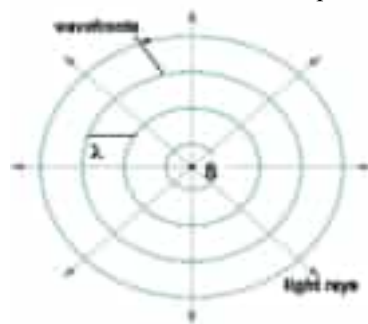

Fig: 13.11
Circular wave fronts

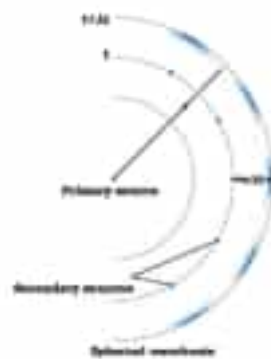

Fig: 13.11 (a)
Spherical wave fronts

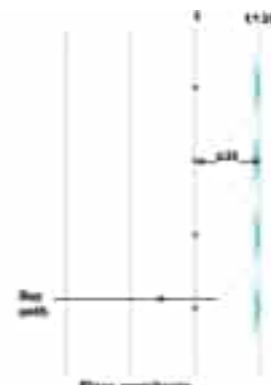

Fig: 13.11 (b)
Plane wave fronts

13.3 Huygens's Principle:

Long before the time development of electromagnetic theory, the Dutch physicist Christian Huygens (1629-1695) developed a geometrical method for explaining the behavior of light when it travels through a medium, when it passes from one medium to another, or when it travels into reflected back from a plan surface.

Huygens's Principle states as,

- i) At some time t , consider every point on a wave front as a source of a new spherical wave. These wavelets move in forward direction from the source as the same speed as the original speed of wave. Fig. 13.11a.
- ii) At a later time $t + \Delta t$, each wave has a radius (distance) $c\Delta t$, where c is the speed of wave (light). The new position of the wave front after time $t + \Delta t$ can be found by drawing a plane tangential to all the secondary wavelets.

Huygens's principle has provided a logical reasoning to understand the phenomena of interference and diffraction of light.

Self-Assessment Questions:

1. Describe a wavefront. How plane wavefronts are emerged out of spherical wave fronts?
2. What is meant by Huygens's Principle?

13.4 Interference of Light:

Interference of light waves, like interference of sound waves, is a manifestation of the principle of superposition which says that

The net wave amplitude (intensity) at any point due to two or more waves, is the sum of the amplitudes of each individual wave.

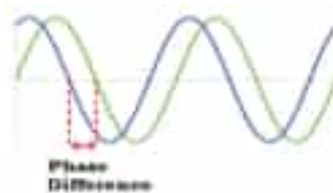

Fig: 13.12

13.4.1 Conditions for interference of light:

Coherent and Incoherent Sources:

Although any number of waves can in principle interfere, but in order to keep the case simple we consider here the interference of only two waves. To produce observable interference effect, it is necessary to have

- Two **coherent** sources. i.e., they must have the same frequency.
- The two waves must be **monochromatic** i.e, they must have the same color (wavelength).
- Be always in phase with each other or have a constant phase difference.

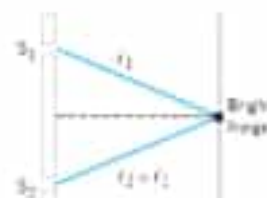

Fig: 13.12 (a)

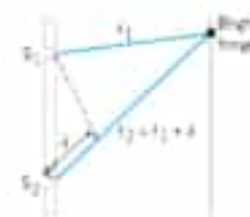

Fig: 13.12 (b)

- For Constructive Interference (Bright Fringes) the path difference must be

$$\text{Phase difference} = 2m\pi \text{ rad}$$

$$\text{Path difference } \Delta S = m\lambda$$

($m = 0, \pm 1, \pm 2, \pm 3, \dots$) Fig. (13.13 a,b)

- For Destructive Interference (Dark Fringes) the phase difference must be

$$\text{Phase difference} = (m + \frac{1}{2}) 2\pi \text{ rad}$$

$$\text{Path difference } \Delta S = (m + \frac{1}{2}) \lambda$$

($m = 0, \pm 1, \pm 2, \pm 3, \dots$) Fig. (13.13 c)

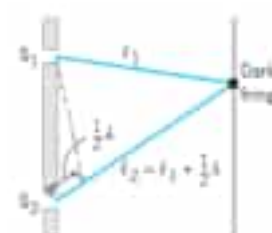

Fig: 13.13 (c)

Phase difference and path difference between two coherent sources

13.4.2 Young's Double Slit Experiment:

Thomas Young performed his double slit experiment not only demonstrated the wave nature of light, but also allowed the first measurement of wavelength of light. Figure.13.14 shows the setup for Young's experiment.

The Principle:

The interference of light waves in Young's experiment can be explained using Huygens's principle.

The Experiment:

Monochromatic light of wavelength " λ " illuminates a narrow slit of width comparable to wavelength of light λ . The light waves that pass through the slit C spread out as spherical wavefronts. The single slit C acts as a single coherent source to illuminate two other slits A and B equidistant from slit C. The two slits are separated by a distance d from their centers. These two slits then act as source of coherent light for interference. Spherical waves spread out of both slits and interfere on a screen at a distance L from the slits. The light from the two narrow slits A and B start out in phase, but travel different paths to reach the screen. We expect constructive interference (red maxima) at O the centre of the screen as the waves travel the same distance and so are in phase and having zero path difference.

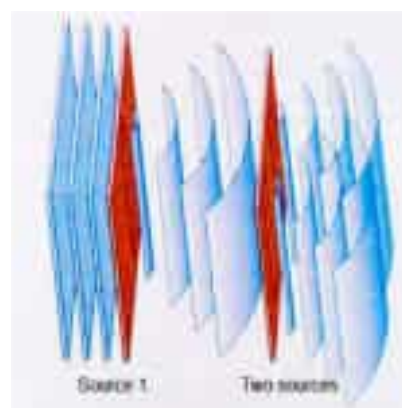

Fig: 13.14

Thomas Young's technique for obtaining two coherent sources from one source.

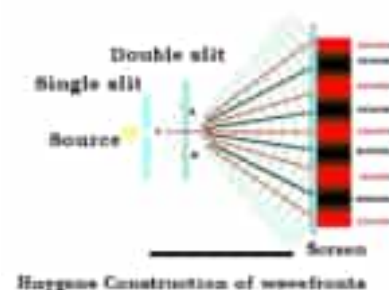

Fig: 13.15 A double slit interference pattern from two coherent sources using Huygens's principle.

13.4.3 Analytical Treatment of Interference:

To find where constructive or destructive interference occurs, we need to calculate the path difference ΔS . Figure.13.16 shows that two rays from two narrow slits A and B separated by a distance d arriving at an arbitrary point P on the screen. The screen is at a distance L from the slits such that $L \gg d$. It is clear from the figure that the waves travelling from the slit B to point P covers distance ΔS greater than the waves from slit A.

The path difference ΔS can be calculated by considering the right angle triangle ABD.

$$\sin\theta = \frac{BD}{AB} = \frac{\Delta S}{d}$$

$$\Delta S = d \sin\theta \quad \dots\dots(13.1)$$

If the path difference between two waves arriving at point P on screen is integral multiple of λ then constructive interference is observed

Therefore : $m\lambda = d \sin\theta \quad \dots\dots (13.2)$

Where: $m = 0, \pm 1, \pm 2, \pm 3, \dots$

For the central point O, we have $m = 0$ called zeroth order maxima and bright fringe is observed. The higher order maxima (bright fringes) are symmetrically located on right and left of the point O. Conversely, if the path difference between the two waves reaching at point P is half integral multiple of wavelength λ , then a dark fringe is obtained.

Therefore $(m + \frac{1}{2}) \lambda = d \sin\theta$

where: $m = 0, \pm 1, \pm 2, \pm 3, \dots (13.3)$

Position of Fringes on the Screen:

The position of bright and dark fringes can be calculated by determining an expression for $Y = OP$ on the screen (Fig. 13.17). As mentioned earlier that L the distance from the slits to screen is much larger than the slit spacing d . In actual practices L is of the order of 1m compared to slits spacing which is of the order of fractions of millimeters. Since θ is very small, hence Y is much smaller than L and $PQ \approx QO$. Under this condition the right angle triangles ABD and PQQ are similar,

Therefore: $\sin\theta \approx \tan\theta$

In Fig.13.17 consider the right angle triangle PQQ

$$\sin\theta \approx \tan\theta = \frac{Y}{L} \quad \dots\dots (13.4)$$

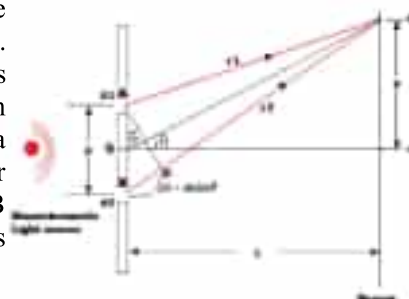

Fig: 13.16 A geometrical illustration of Young's double slit

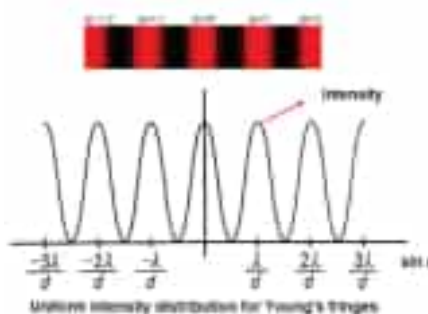

Fig: 13.17 Uniform intensity pattern of fringes. Red (constructive interference) black (destructive interference).

Comparing the equation (13.4) with the condition of constructive interference from equation (13.2), we can locate the positions of bright fringes on the screen

$$m \lambda = d \frac{Y}{L} \quad \text{or} \quad Y = \frac{\lambda L}{d} m \quad \dots\dots (13.5)$$

For the m^{th} bright fringe replace Y by Y_m . Therefore equation (13.5) can now be written as, Position of m^{th} Bright Fringe

$$Y_m = \frac{L}{d} m \lambda \quad \dots\dots (13.6)$$

Similarly for the position of dark fringes, equation (13.4) is compared with the condition of destructive interference from equation (13.3).

Position of m^{th} Dark Fringe

$$Y_m = \frac{L}{d} \left(m + \frac{1}{2}\right) \lambda \quad \dots\dots (13.7)$$

Fringe Spacing:

Fringe spacing Δx is the distance between two consecutive bright or dark fringes. Using equation (13.6) or (13.7) the fringe spacing of two bright or dark fringes can be calculated.

For first and second bright fringe;

$$\Delta x = Y_2 - Y_1 = 2\left(\frac{L}{d} \lambda\right) - 1\left(\frac{L}{d} \lambda\right)$$

Fringe spacing between two consecutive bright fringes

$$\Delta x = \frac{L}{d} \lambda \quad \dots\dots (13.8)$$

Worked Example 13.1

In a Young's double slit experiment a beam of light consisting of two wavelengths, 6500 \AA and 5200 \AA , is used to obtain interference fringes on a screen 120 cm away from two slits 2 mm apart. (i) Find the distance of the third bright fringe on the screen from the central maxima for the wavelength 6500 \AA (ii) What is the least distance from the central maximum where the bright fringes due to both the wavelengths coincide.

Solution:

Step 1: Write the known quantities and point out quantities to be found.

Distance of the screen from slits; $L = 120 \text{ cm} = 120 \times 10^{-2} \text{ m}$

Slits spacing; $d = 2 \text{ mm} = 2 \times 10^{-3} \text{ m}$

Wavelength of light; $\lambda_1 = 6500 \text{ \AA} = 6500 \times 10^{-10} \text{ m}$

Wavelength of light; $\lambda_2 = 5200 \text{ \AA} = 5200 \times 10^{-10} \text{ m}$

Required:

a) Distance of third bright fringe from central maxima for 6500 \AA ; $\Delta x = ?$

b) Least distance from the central maximum where the bright fringes due to both the wavelengths coincide; $x = ?$

Step 2: Write down the formula and rearrange if necessary

$$Y_m = \frac{L}{d} m \lambda; \text{ for } m = 3$$

$$Y_3 = \frac{L}{d} 3 \lambda$$

$$\Delta x = Y_3 - Y_0 = \frac{L}{d} 3 \lambda$$

Step 3: Put the values in the formula and calculate.

a) $\Delta x = \frac{120 \times 10^{-2}}{2 \times 10^{-3}} \times 3 \times 6500 \times 10^{-10}$

$\Delta x = 1.17 \times 10^{-3} \text{ m} = 117 \text{ mm}$ Answer

b)

Suppose the m^{th} bright fringe due to wavelength 6500 \AA coincides with the n^{th} bright fringe due to wavelength 5200 \AA then,

$$Y_m = Y_n \rightarrow \frac{L}{d} m \lambda_1 = \frac{L}{d} n \lambda_2 \rightarrow m \lambda_1 = n \lambda_2$$

$$\frac{m}{n} = \frac{5200 \text{ \AA}}{6500 \text{ \AA}} = \frac{4}{5}$$

Hence the minimum values of m and n for the two bright fringes coincide are

$m = 4$ and $n = 5$

Therefore; $x = \frac{L}{d} m \lambda_1 \rightarrow x = \frac{120 \times 10^{-2}}{2 \times 10^{-3}} \times 4 \times 6500 \times 10^{-10}$

$x = 1.56 \times 10^{-3} \text{ m} = 1.56 \text{ mm}$

Similarly; $x = \frac{L}{d} n \lambda_2 = \frac{120 \times 10^{-2}}{2 \times 10^{-3}} \times 5 \times 5200 \times 10^{-10}$

$x = 1.56 \times 10^{-3} \text{ m} = 1.56 \text{ mm}$

13.4.4 Interference in Thin Films:

In search of the true mechanism of formation of colors through interference in thin films, we consider a thin film of thickness t and index of refraction n . From (Fig.13.19) the ray OA assume to be the part of monochromatic source of light of wavelength λ incident normally on the film. The ray OA is partly reflected as ray AB from the air-glass interface and partly transmitted through the film as ray AC. At point C at the glass-air boundary another partial reflection and refraction occur.



Fig: 13.18

The rainbow – like colors seen in soap bubbles and oil slicks are produced by interference

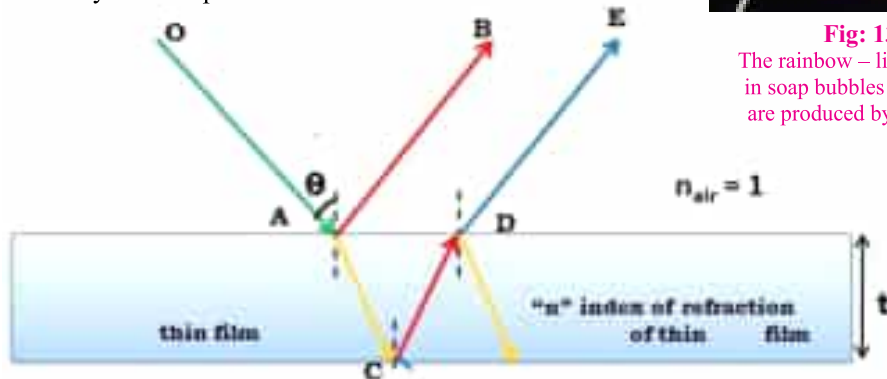

Fig: 13.19

Multiple reflection (red) and refraction (blue) of rays through the top and bottom interfaces of thin film.

Reflected light (CD) emerges from the film as a refracted ray (DE). The interference between these rays (AB and DE) leads to constructive or destructive interference, determined by their phase difference. Reflection occurs when a wave encounters a medium with a higher refractive index, resulting in a completely inverted reflected wave with a phase shift of 180 degrees as shown in figure 13.19. The refracted ray experiences no phase change. In the case of transmission from a higher to a lower refractive index medium, no phase change occurs. The reflected ray (AB) undergoes a phase reversal, while the refracted ray (DE) passes through without any phase change. Consequently, the 180-degree phase difference between rays AB and DE causes them to interfere constructively or destructively.

Path Difference for a Normal Incidence of light:

In figure 13.19 the monochromatic light of wavelength λ incident perpendicularly on a thin film of thickness t . The refracted ray from A has to travel twice in the film before transmitting out of the film at D. Thus the path difference between AB and DE will be:

$$\text{Path Difference} = 2t \quad \dots\dots (13.9)$$

$$2t = (m + 1/2) \lambda = \text{constructive}$$

$$2t = m \lambda = \text{destructive}$$

Wavelength Shift due to Refraction:

In figure 13.20, Interference through thin films involves two media of different indices of refraction. The wave (AB) reflected through the interface has wavelength λ , while the wave (DE) transmitted through the medium of refractive index n having slightly different wavelength, mark as λ_n .

$$\text{Given as } \lambda_n = \frac{\lambda}{n} \quad \dots\dots (13.10)$$

By virtue of the phase reversal between the ray AB and DE the conditions for constructive and destructive interference are reversed compared to Young's double slit experiment

Phase Reversal due to Reflection

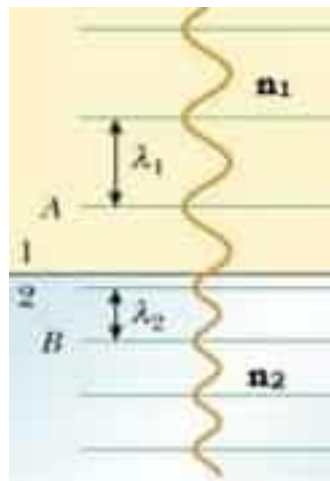

Fig.13.20

Change of wavelength between incident and refracted wave due to different indices of refraction.

DO YOU KNOW?



The shimmering blue color of Morpho butterflies is a striking example of interference in thin film. The tree-like structures on their wings made of transparent material reflect light from a series of steps, creating different path lengths for interfering rays and angles of view, resulting in the beautiful sparkling blue color.

Worked Example 13.2

A soap bubble in air is of thickness 320 nm. If it is illuminated with white light at near normal incidence, what color will appear to be in reflected light?

(Refractive index of soap bubble $n = 1.50$).

Solution:

Step 1: Write the known quantities and point out the quantities to be found.

Thickness of film,	$t = 320 \text{ nm}$
Refractive index,	$n = 1.50$
Wavelength	$\lambda = ?$
Colors	$= ?$

Step 2: Write the formula and rearrange if necessary.

$$2nt = \left(m + \frac{1}{2}\right) \lambda$$

$$\lambda = \frac{2nt}{m + \frac{1}{2}}$$

$$m = 0, 1, 2, 3, \dots$$

Step 3: Put the values in the formula and calculate.

$$\lambda = \left\{ \frac{2nt}{m + \frac{1}{2}} \right\} \text{ nm}$$

for $m = 0$,

$$\lambda = \left\{ \frac{2 \times 1.50 \times 320}{0 + \frac{1}{2}} \right\} \text{ nm} = \left\{ \frac{2 \times 1.50 \times 320}{0 + \frac{1}{2}} \right\} \text{ nm}$$

$\lambda = 1920 \text{ nm}$, similarly

for $m = 1$, $\lambda = 640 \text{ nm}$

for $m = 2$, $\lambda = 384 \text{ nm}$

for $m = 3$, $\lambda = 274 \text{ nm}$

We note that only the maxima, for $m=1$ and $m=2$ lies in the visible region and the colors for 640 nm 384 nm are nearly red and violet.

13.4.5 Newton's Rings:

If a plano convex lens of radius of curvature R is placed on a flat glass plate. The air gap between the two surfaces will increase from zero at the point of contact of lens and plate to a thickness equal to t , as we move out from the point of contact of lens and flat glass plate to the edge of the lens (Fig.13.21a). If the setup is illuminated by monochromatic light of wavelength λ incident normally on the plano convex lens. Due to the curvature of lens the air film between the lens and glass plate is also spherical. The interference pattern we obtain is in the form of alternate dark and bright concentric rings called Newton's rings.

The center of the rings is the point where air film thickness

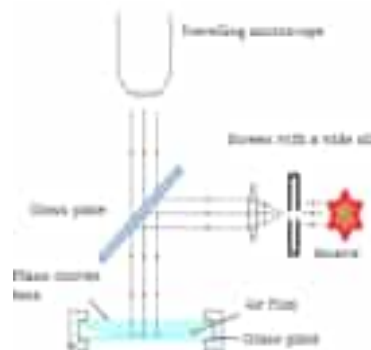

Fig: 13.21 (a)
Experimental set up to observe Newton's rings.

is zero. Thomas Young figured out that the central ring of the interference pattern is a dark spot due to zero path difference and phase reversal of 180° between the rays reflected from the upper and lower surfaces.

Using the geometrical theorem that the product of intercepts of intersecting chords is equal, from figure.13.21 b, we have

$$r^2 = (AB) \times (BC) \quad \dots\dots (13.11)$$

Here, $OA = (2R-t)$ and $BC = t$

Therefore, equation (13.11) can now be written as,

$$r^2 = (2R-t) \times t$$

$$r^2 = 2Rt - t^2$$

Since t is much smaller than the R , therefore neglecting t^2 , we get

$$r^2 = 2Rt \quad \dots\dots (13.12)$$

$$r = \sqrt{2Rt} \quad \dots\dots (13.13)$$

Since the condition for bright ring in thin films is give by equation

$$2nt = (m + \frac{1}{2}) \lambda \quad \text{For air } n = 1$$

Therefore, $2t = (m + \frac{1}{2}) \lambda$

Hence for first bright ring $m=0$ $2t_1 = \frac{1}{2} \lambda$

For second bright ring, $m=1$ We write, $2t_2 = \frac{3}{2} \lambda$

Similarly for N^{th} bright ring $N = m+1$, therefore $m = N - 1$

$$2t_N = (N - \frac{1}{2}) \lambda$$

Substituting the value of $2t_N$ in equation 13.13, we get the radius of N^{th} bright ring.

$$r = \sqrt{R \left(N - \frac{1}{2} \right) \lambda \lambda} \quad \dots\dots (13.14)$$

Similarly the condition for destructive interference in thin films is give by equation 13.14 and hence the radius of m^{th} dark ring.

$$r = \sqrt{m\lambda R} \quad \dots\dots (13.15)$$

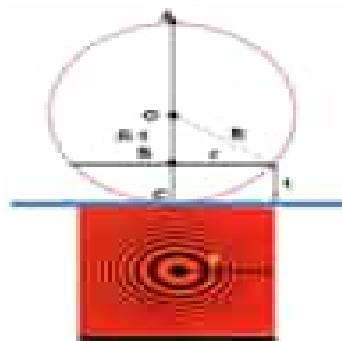

Fig: 13.21 (b)
Experimental set up to observe
Newton's rings.

Worked Example 13.3

In a Newton's ring experiment the diameter of the 16th bright ring was found to be 0.653 cm and that of 5th bright ring is 0.346 cm. if the radius of curvature of the lens is 100 cm, find the wavelength of light.

Solution:

Step 1: Write the known quantities and point out the quantities to be found.

Diameter of Newton's 16th bright ring

$$(d_{16}) = 0.653 \text{ cm} = 0.653 \times 10^{-2} \text{ m}$$

Radius of Newton's 16th bright ring

$$r_{16}^b = 3.265 \times 10^{-3} \text{ m}$$

Diameter of Newton's 5th dark ring
 $(d_5) = 0.346 \text{ cm} = 0.346 \times 10^{-2} \text{ m}$
 Radius of Newton's 5th dark ring
 $r_5^d = 1.73 \times 10^{-3} \text{ m}$
 Radius of curvature of lens, $R = 100 \text{ cm} = 1 \text{ m}$
 Wave length of light $(\lambda) = ?$

Step 2: Write the formula and rearrange if necessary.

From equation 13.17 and 3.18,
 $r_b^2 = R(N - \frac{1}{2})\lambda$ and $r_d^2 = m\lambda R$
 $r_b^2 - r_d^2 = R(N - \frac{1}{2})\lambda - m\lambda R$
 $\lambda = \frac{r_b^2 - r_d^2}{(N - \frac{1}{2} - m)}$

Step 3: Put the values in the formula and calculate.

$$\lambda = \frac{(3.265 \times 10^{-3})^2 - (1.73 \times 10^{-3})^2}{(16 - \frac{1}{2} - 5)}$$

$$\lambda = 7302 \times 10^{-10} \text{ m}$$

The Michelson Interferometer:

Michelson Interferometer is an important device of second class having very high sensitivity and accuracy to measure the wavelength of light.

Experimental Setup:

The main optical parts of Michelson interferometer shown in figure.13.22 consists of two highly polished plane mirrors M_1 and M_2 and two parallel plane plate of glasses, A which is half silvered used as beam splitter inclined at an angle of 45° relative to the path of incident light and B a plain glass plate with same angle and thickness used as compensator plate. Monochromatic light of wavelength λ from an extended source S probably obtained through a sodium flame or mercury arc is divided by beam splitter into (i) a reflected beam and (ii) a transmitted or refracted beam of equal intensity. The two beams emerging from beam splitter A travel perpendicular paths to mirrors M_1 and M_2 as reflected and refracted beams respectively, where they are directed back to be recombined at the beam splitter. The beam from mirror M_1 is partly reflected at A, but part of that

DO YOU KNOW?

It was made and used in the United States by Albert Michelson (1852-1931) in 1887.

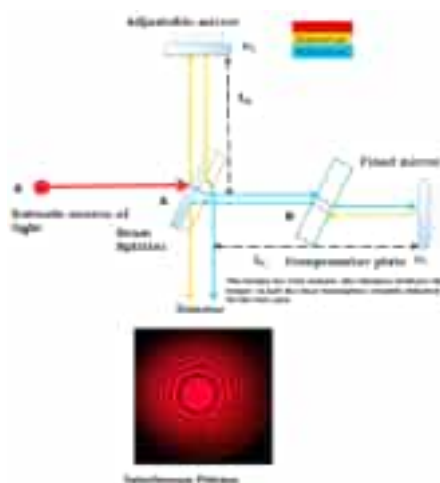

Fig: 13.22 The Michelson Interferometer, showing the path of light and interference pattern.

beam refracts through A and goes to the detector. The beam from mirror M_2 partially refracts through A and lost, but part of that beam is also reflected towards the detector. The purpose of compensator plate B is to ensure the same path length for the two rays. Since the transmitted ray through A towards M_1 pass through plate B twice (Fig. 13.22) and thus the path length across in glass by the light in this arm is identical to that travelled in the glass in the other arm. If fringes are produced with monochromatic light, presence of B is not essential. But it produces a serious problem when white light is used because white light has broad spectrum. Inclusion of compensator negates the effect of dispersion. Thus, the two waves will interfere constructively or destructively as per following the conditions of path difference. Path difference between the two rays can be varied by moving M_2 .

DO YOU KNOW?

The Michelson Interferometer

Michelson interferometer is a versatile optical instrument used in various scientific and engineering applications to measure small displacements, wavelengths of light, and refractive indices, among other parameters.



Nature of Fringes:

If M_1 and M_2 are equidistant from the beam splitter A the field of view will be perfectly dark. If the mirror M_1 is kept fixed and the mirror M_2 is moved a distance of $\lambda/4$ with the help of the fine movement screw the path difference changes to $\lambda/2$ and the number of fringes that cross the field of view is counted. The wavelength is determined from the fact that for one fringe shift, the mirror moves through a distance equal to half the wavelength. If d is the distance moved by M_2 and m the number of fringes shifted, then,

$$x = m \frac{\lambda}{2}$$

Self-Assessment Questions:

1. Describe the conditions for constructive and destructive interference.
2. What causes the change of interference conditions in thin films?
3. Why compensator plate is important in Michelson interferometer?

13.5 Diffraction of Light:

Suppose a plane wave approaches an obstacle. Using geometric optics, we would expect the rays not blocked by the obstacle to continue straight ahead, forming a sharp, well-defined shadow on a screen beyond the obstacle. If the obstacle is large compared to (Fig. 13.23) the wavelength of light, then geometric optics gives a good approximation to what actually happens and we will observe that,

- (i) Geometrical shadow of the obstacle is uniformly dark because no light is reaching within the geometry of object.
- (ii) The surrounding of geometrical shadow is uniformly illuminated.



Fig: 13.23
The geometrical shadow of an extended obstacle.

13.5.1 Diffraction of light is an interference phenomenon:

If the obstacle is not large compared to the wavelength, we must return to Huygens's principle to show how a wave bends within the geometry of obstacle. In (Fig. 13.24 a), a wavefront just reaches a barrier with an opening in it. Every point on that wavefront acts as a source of spherical wavelets. Points on the wavefront that are behind the barrier have their wavelets absorbed or reflected. Therefore, the propagation of the wave is determined by the wavelets generated by the unobstructed part of the wavefront.

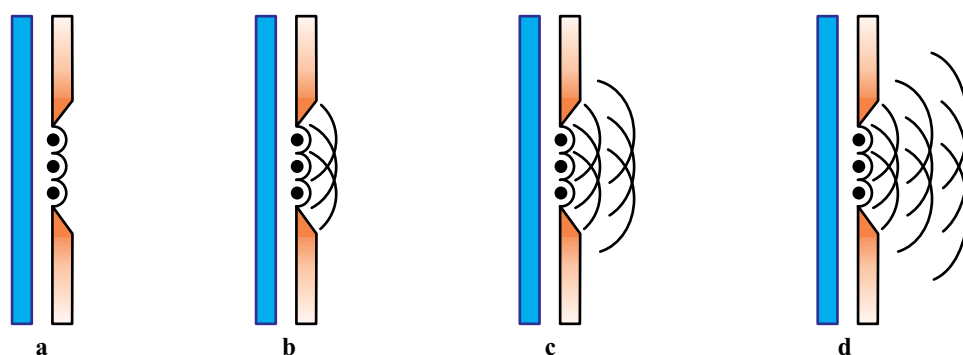

Fig: 13.24 (a) A plane wave reaches the barrier. Points along the wavefront act as sources of spherical wavelets. (b, to d) At later times, the initial wavelets are propagating outward as new ones from the wavefront bends around the edges of the barrier.

The Huygens's construction in (Fig. 13.24 b-d) shows that, the wave bends around the edges of the barrier, something that would not be expected in geometric optics. Fig.13.25 shows the shadow of a razor blade illuminated by a monochromatic source of light. The bright and dark fringes are observed near the edges of geometrical shadow of the blade. This confirms the novel idea of

“Bending of light around obstacles and spreading of light waves into the geometrical shadow of an obstacle”. This phenomenon is called Diffraction of Light”



Fig: 13.25 Diffraction pattern formed when a razor blade is illuminated with a monochromatic light

13.5.2 Wave nature of Light through Diffraction:

In general, Interference refers to situations where waves from a small number of sources, travel different paths and arrive at a point with different phases. Diffraction is the bending of waves when they travel around obstacles or through apertures. According to Huygens's principle, *every point on a wave front is a source of secondary wavelets*. Thus the superposition (interference) of light from all these point sources is called diffraction of light, provided the conditions of phase coherence and path difference are fulfilled.

DO YOU KNOW?

Discovered by Francesco Maria Grimaldi (1618-1663). The distinction between interference and diffraction is not always straightforward.

<i>Interference</i>	<i>Diffraction</i>
Interference fringes are obtained due to the superposition of light coming from two different wavefronts originating from two coherent sources.	Diffraction fringes are obtained due to the superposition of light coming from different parts of same wavefront.
The width of interference fringes is generally same.	The width of interference fringes is not same.
The intensity of all the bright fringes is same.	The intensity of all the bright fringes is not same. It is maximum for central fringe and decreases sharply for first, second fringes and so on.

13.5.3 Diffraction by a Single Slit:

In a more detailed treatment of diffraction, we must consider the phases of all the Huygens wavelets and apply the principle of superposition. (Fig.13.26) shows the diffraction pattern formed by light passing through a single slit. A wide central maximum contains most of the light energy. (Central maximum is the usual way to refer to the entire bright band in the center of the pattern, although the actual maximum is just at $\theta = 0$. A more accurate name is central bright fringe.) The intensity is brightest right at the center and falls off gradually until the first minimum on either side, where the screen is dark. According to Huygens's principle, the diffraction of the light is explained by considering every point along the slit as a source of wavelets (Fig. 13.27). The light intensity at any point beyond the slit is the superposition of these wavelets. The wavelets start out in phase, but travel different distances to reach at a given point on the screen. The structure in the diffraction pattern is a result of the interference of the wavelets. This is a much more complicated interference problem than the interference we have encountered in Young's experiment because an infinite number of waves interfere, and every point along the slit is a source of wavelets. Figure.13.27 shows two rays that represent the propagation of two wavelets: ray 1 from the top edge of the slit and ray 2 from exactly half way down. The rays are off at the same angle θ to reach the same point on a distant screen. The lower one travels an extra distance ($\frac{1}{2} a \sin\theta$) to reach the screen. If this extra distance is equal to $\frac{1}{2}\lambda$ then these two wavelets interfere destructively. Now let's look at two other wavelets, shifted down distance ΔS so that they are still separated by half the slit width ($\frac{1}{2} a$). The path difference between these two rays must be $\frac{1}{2}\lambda$ so

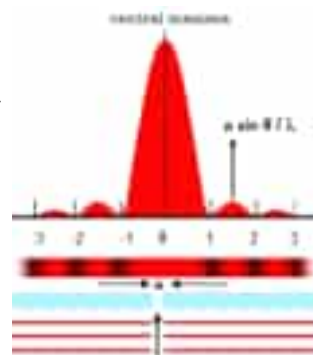

Fig: 13.26 Single slit diffraction. The intensity of light is gradually decreasing from right and left of central maxima

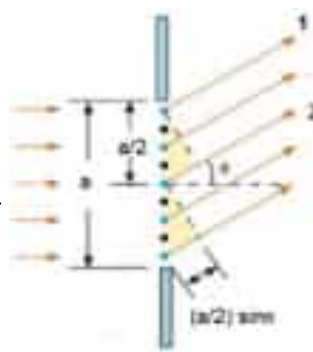

Fig: 13.27 Every point along a slit serves as a source of Huygens wavelets. Ray 2 travels a greater distance to reach the screen than the ray 1.

that these two interfere destructively. All the wavelets can be paired off; since each pair interferes destructively, no light reaches the screen at that angle. Therefore, the first diffraction minimum occurs where;

$$\frac{1}{2} a \sin\theta = \frac{1}{2} \lambda$$

$$a \sin\theta = \lambda$$

The other minima are found in a similar way, by pairing off wavelets separated by a distance of $\frac{1}{4} a, \frac{1}{6} a, \frac{1}{8} a, \dots, \frac{1}{2m} a$, where, m is any integer other than zero. The diffraction minima are given by

$$\frac{1}{2m} a \sin\theta = \frac{1}{2} \lambda \quad (m=\pm 1, \pm 2, \pm 3, \dots)$$

$$a \sin\theta = m\lambda \quad \dots (13.16)$$

What happens if the slit is made narrower? As a (slit width) gets smaller, the angle θ for the minima get larger-the diffraction pattern spreads out. If the slit is made wider, then the diffraction pattern shrinks as the angles for the minima get smaller. The angles at which the lateral maxima occur are much harder to find than the angles of the minima: there is no comparable simplification we can use. The central maximum is at $\theta = 0$, since the wavelets all travel the same distance to the screen and arrive in phase.

13.5.4 Diffraction Grating:

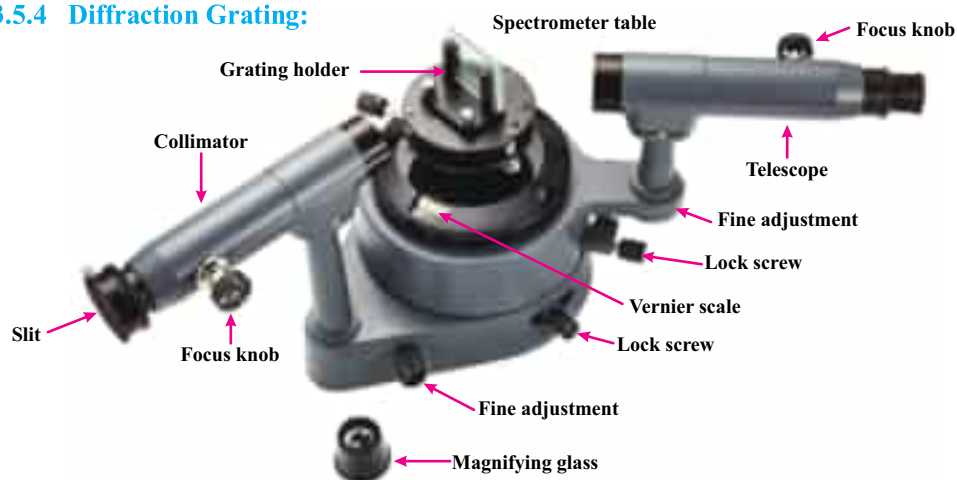

Figure.13.28. A Diffracting spectroscope

Suppose that parallel light is incident on two more parallel close slits, and the light passing through the slits is received by a telescope focused at infinity (Fig.13.28). Since each slit produces a similar diffraction effect in the same direction, the observed diffraction pattern will have an intensity variation identical to that of a single slit. This time however, the pattern is crossed by a number of interference bands, which are due to interference between slits. As more parallel equidistant slits are introduced, the intensity and sharpness of the principal maxima increase and those of the subsidiary maxima decrease. Any arrangement which is equivalent in its action to a large number of parallel evenly spaced slits of equal width is called

diffraction grating. Diffraction grating is a very useful and powerful instrument to study and explore the nature of light.

A diffraction grating is a large number of close parallel equidistant slits, ruled on glass or metal surface;

If the width of a slit or clear space is a and the thickness of a ruled opaque line is b , the spacing d of the slits (Fig. 13.29) is $(a + b)$. Where d is called grating element. If N is the number of slits per unit length, lets for example per cm. Then,

$$N = \frac{1}{d} \quad \dots\dots (13.17)$$

Figure 13.29 shows monochromatic light rays travelling from the slits of the grating to a distant screen. The light from all the evenly spaced slits are collected at a point P on the screen by means of a converging lens. If the path difference $d \sin\theta$, between the light waves from any adjacent pair of slits arriving at P is integral multiple of wavelength λ , they will interfere constructively.

Maxima for grating, $d \sin\theta = n\lambda \quad \dots\dots (13.18)$

($n = 0, \pm 1, \pm 2, \pm 3, \dots$)

For the central maxima there is no path difference, so it is called “Zeroth” order maxima. For the subsequent maxima, first, second orders and so on the path difference should be,

$$\begin{aligned} d\sin\theta &= \lambda && \text{first order maxima} \\ d\sin\theta &= 2\lambda && \text{second order maxima} \end{aligned}$$

For two slits, there is a gradual change in the intensity from maximum to minimum and back to maximum, by contrast, for a grating with a large number of slits, the maxima are narrow and the intensity everywhere else is negligibly small as shown in figure. 13.30.

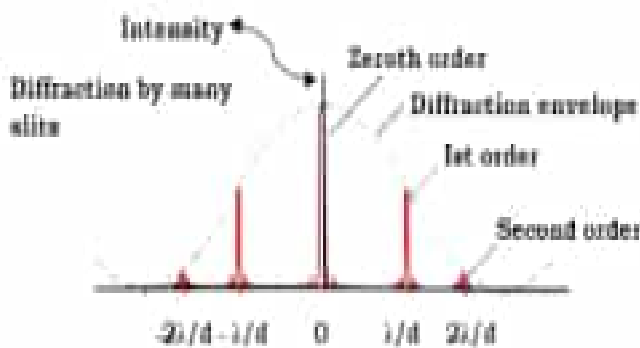

Fig: 13.30
Multiple slits sharp energy spectrum maxima.

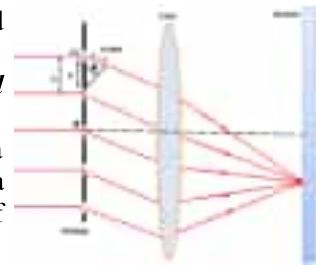

Fig: 13.29 Geometrical illustration of a diffraction grating.



A diffraction grating with 600 lines per mm.

DO YOU KNOW?



To manufacture a CD a disk of polycarbonated plastic 1.2 mm thick is impressed with a series of pits (holes) arrange in a spiral track. The pits are $0.5 \mu\text{m}$ wide and at least $0.83 \mu\text{m}$ long. These pits function as a diffraction grating. So when white light shines the surface of disc it diffracts through the pits and formed a rainbow like pattern.

13.5.5 X-Ray Diffraction:

The interference and diffraction examples discussed so far have dealt mostly with visible light. However, the same effects occur for wavelengths longer and shorter than those visible to our eyes. X-ray radiation has wavelengths much shorter than those of visible light, so to do such an experiment, the size and spacing of the slits in a grating (for example) would have to be much smaller than in a visible-light grating. **Typical X-ray wavelengths range from about 10 nm to about 0.01 nm.**

There is no way to make a parallel-slit grating small enough to work for X-rays: the diameter of an atom is typically around 0.2 nm, so the slit spacing would be about the size of a single atom. In 1912, Max von Laue (1879–1960) realized that the regular arrangements of atoms in a crystal make a perfect grating for x-rays. The regular arrangement and spacing of the atoms is analogous to the regular spacing of the slits in a conventional grating, but a crystal is a *three-dimensional* grating (as opposed to the two-dimensional gratings we use for visible light). Figure 13.31a shows the atomic structure of NaCl. When a beam of x-rays passes through the crystal, the x-rays are scattered in all directions by the atoms. The x-rays scattered in a particular direction from different atoms interfere with each other. In certain directions they interfere constructively, giving maximum intensity in those directions. Photographic film records those directions as a collection of spots for a single crystal, (Fig. 13.31b).

Measurement of Interplanar Spacing ‘d’:

Determining the directions for constructive interference is a difficult problem due to the three-dimensional structure of the grating. W. L. Bragg discovered a great simplification. He showed that we can think of the x-rays as if they reflect from planes of atoms (Fig. 13.32a).

Constructive interference occurs if the path difference between X-rays reflecting from an adjacent pair of planes is an integral multiple of the wavelength.

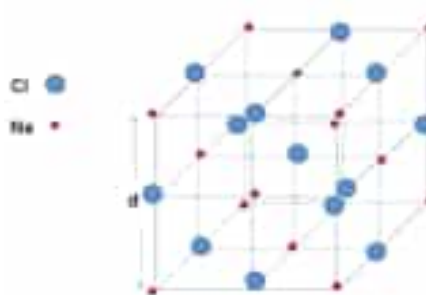

Fig: 13.31 (a) Crystal structure of NaCl (Rock salt).

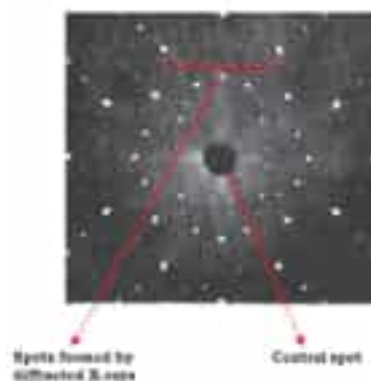

Fig: 13.31 (b) The X-ray diffraction pattern of NaCl. The central spot created by X – rays that are not scattered by the sample.

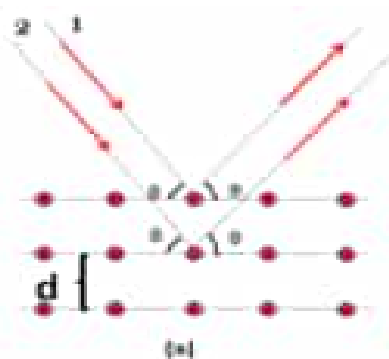

Fig: 13.32 (a) Incident X-rays behave as if they reflect from parallel planes of atoms.

Figure 13.32b shows that the path difference is $2d\sin\theta$, where d is the distance between the planes and θ is the angle that the incident and reflected beams make with the plane (not with the normal). Then, constructive interference occurs at angles given by Bragg's law:
 $p. d = BD + CD = d\sin\theta + d\sin\theta = 2d\sin\theta \dots (13.19)$

X-ray diffraction maxima
 $2d\sin\theta = m\lambda \dots (13.20)$
 $(m = \pm 1, \pm 2, \pm 3, \dots)$

Although Bragg's law is a great simplification, x-ray is still very complicated because there are many sets of parallel planes in a crystal each with its own plane spacing. In practice, the largest plane spacing contains the largest number of scattering centers (atoms) per unit area so they produce the strongest maxima.

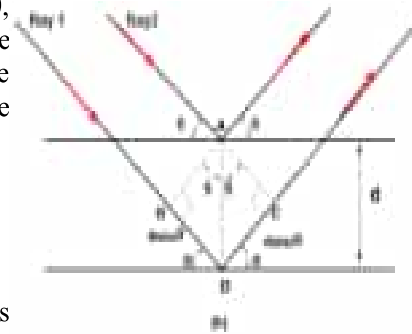

Fig: 13.32 (b) Geometry for finding the path difference for rays reflecting from two adjacent planes.

Self-Assessment Questions:

1. Why do you think the diffraction of light is an interference phenomenon?
2. What are the factors which determine the number of order of diffraction obtainable when light is incident normally on a diffraction grating?
3. Why do x-rays are used to obtain a diffraction pattern through crystal?



SUMMARY

- Only accelerating charges produce electromagnetic waves. EM waves consist of oscillating electric and magnetic fields that propagate away from the source.
- EM waves always have both electric and magnetic fields. Just as changing magnetic fields give rise to electric fields, changing electric fields give rise to magnetic fields.
- The electromagnetic spectrum, the range of frequencies and wavelengths of EM waves is traditionally divided into named regions. From lowest to highest frequency, they are radio waves, microwaves, infrared, visible, ultraviolet, x-rays, and gamma rays.
- A wavefront is a set of points of equal phase. A ray points in the direction of propagation of a wave and is perpendicular to the wavefront.
- Huygens's principle is a geometric construction used to analyze the propagation of a wave.
- Every point on a wave is considered to be a source of spherical wavelets. A surface tangent to the wavelets at a later time is the wavefront at that time.
- When two coherent waves are in phase, their superposition results in constructive interference.
- When two coherent waves are 180° out of phase, their superposition results in destructive interference.
- For Constructive interference phase difference = $2m\pi$ rad and path difference = $\Delta S = m\lambda$, ($m = 0, \pm 1, \pm 2, \pm 3, \dots$)
- For Destructive interference phase difference = $(m + \frac{1}{2}) 2\pi$ rad and path difference = $\Delta S = (m + \frac{1}{2}) \lambda$, ($m = 0, \pm 1, \pm 2, \pm 3, \dots$)
- A path length difference equal to λ causes a phase shift of 360° (2π rad). A path length difference of $(\frac{1}{2})\lambda$ causes a phase shift of 180° (π rad).
- When light reflects from a boundary with higher index of refraction, it is inverted 180° out of phase. When light reflects from the boundary of lower index of refraction it is not inverted.
- The angle at which the bright (maxima) and dark fringe (minima) occur in a double slit experiment are $m\lambda = d \sin\theta$ and $(m + \frac{1}{2}) \lambda = d \sin\theta$, d is the distance between the slits and m is the order of maxima or minima.
- A grating with N slits produces maxima that are narrow and bright (width = $1/N$).
- The minima in a single slit diffraction pattern occur at angles given by $a \sin\theta = m\lambda$.
- A wide central maximum contains most of the light energy, the other maxima are approximately half way between adjacent maxima.
- The rectangular arrangement of atoms in a crystal makes a grating for x-rays.
- The x-rays behave as they reflect from the atomic planes. Constructive interference occurs if the path difference between x-rays reflecting from an adjacent pair of planes is an integral multiple of wavelength.

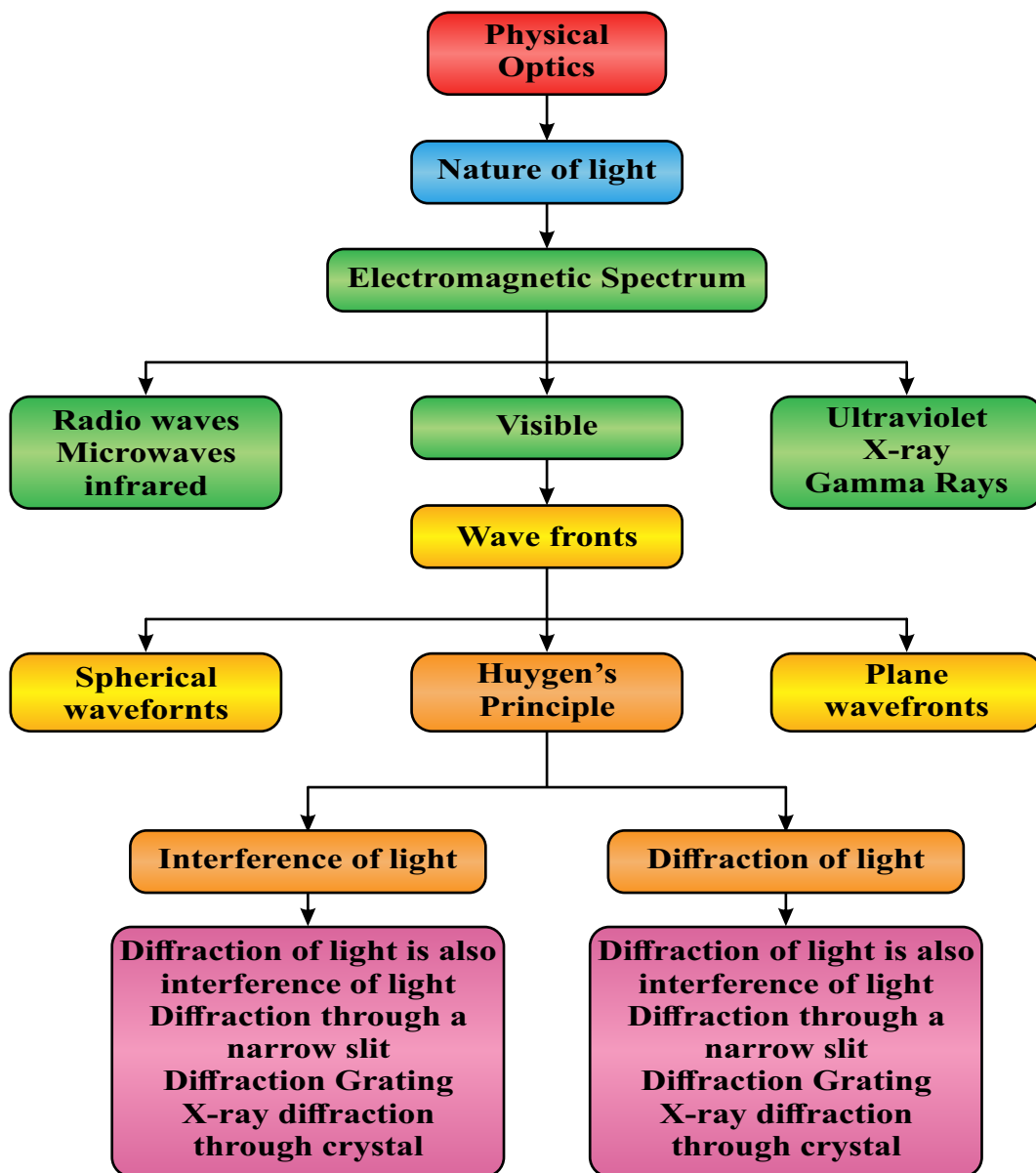



EXERCISE

Section (A): Multiple Choice Questions (MCQs)

- If the wavelength of an electromagnetic wave is about the diameter of a cricket ball, what type of radiation is it.
 - X-ray
 - Ultraviolet
 - Radio waves
 - Visible light
- Electromagnetic waves from an unknown source in space are found to be diffracted when passing through gaps of the order of 10^{-5} m, which type of the wave are they most likely to be?
 - microwaves
 - Ultraviolet
 - Radio waves
 - infra-red waves
- Huygens's conception of secondary waves
 - helps us to find the focal length of a thick lens
 - is a geometrical method to find a wavefront
 - is used to determine the velocity of light
 - is used to explain the polarization of light
- Interference fringes are produced using monochromatic light of same intensity from a double slit screen. If the intensity of light emerging from one of the slit is reduced, the effect on interference pattern will be
 - All the dark and bright fringes become brighter.
 - All the dark and bright fringes become darker.
 - Bright fringes become brighter and dark fringes become darker.
 - Bright fringes become darker and dark fringes become brighter.
- In Young's experiment when the distance between slits and screen is doubled, while separation of slits is halved, then fringe width will be;
 - 4 times
 - $\frac{1}{4}$ times
 - doubled
 - unchanged
- A ray of light passes from air into water. Striking the surface of the water with an angle of incidence 45° . Which of these quantities change as the light enters the water.i) Wavelength ii) frequency iii) speed of propagation iv) direction of propagation
 - i and ii only.
 - iii and iv only.
 - i, iii, and iv only.
 - all of them.
- A hill separates a television (TV) transmitter from a house. The Transmitter cannot be seen from the house but still the TV in the house has good reception. What wave phenomena make it possible?
 - Coherence of waves
 - Diffraction of waves
 - Interference of waves
 - Refraction of waves
- Monochromatic light is incident on a diffraction grating and a diffraction pattern is observed. Which effects is observed by replacing the grating with one that has more lines per millimeter?
 - Number of maxima decreases with decrease in angle between first and second order maxima.

- b) Number of maxima decreases with increase in angle between first and second order maxima.
 - c) Number of maxima increases with decrease in angle between first and second order maxima.
 - d) Number of maxima increases with increase in angle between first and second order maxima.
9. Optically active substances are those substances which
- a) produce polarized light
 - b) rotate the plane of polarization of polarized light
 - c) produce double refraction
 - d) convert a plane polarized light into circularly polarized light
10. Plane polarized light is passed through a Polaroid. On viewing through the Polaroid we find that when Polaroid is given one complete rotation about the direction of light
- a) The intensity of light gradually decreases to zero and remains at zero.
 - b) The intensity of light gradually increases to maximum and remains at maximum.
 - c) There is no change in the intensity of light.
 - d) The intensity of light varies such that it is twice maximum and twice zero.

CRQs

1. In every day experience, visible light seem to travel in straight lines while radio waves do not, Explain.
2. Explain why two waves of significantly different frequencies cannot be coherent?
3. In a Young's double slit experiment, how the interference phenomenon is affected by changing the slits separation and the distance between the slits and screen?
4. Explain how the double-slit experiment provides evidence for the wave nature of light.
5. Discuss the concept of monochromatic light in the context of Newton's rings.
6. Explain why monochromatic light is preferred for obtaining clear and well-defined interference patterns in the experiment.
7. Discuss how the interference of light waves leads to the formation of bright and dark rings in the experiment.

ERQs

1. Explain the concept of interference in physical optics. Discuss constructive and destructive interference.
2. Discuss the conditions required for interference and provide examples of interference in daily life.
3. Describe the setup and working principle of the Michelson interferometer. Also explain how the Michelson interferometer can be used to measure the wavelength of monochromatic light.
4. Describe the setup and procedure of the diffraction of X-rays through a crystal experiment.

Numerical:

1. A monochromatic light of wavelength 6900\AA is used to illuminate two parallel slits. On a screen that is 3.30 m away from the slits, interference fringes are observed. The distance between adjacent bright fringes in the centre of the pattern is 1.80 cm. what is the distance between the slits. **(1.265×10^{-4} m)**
2. A Michelson interferometer is adjusted so that a bright fringe is appears on the screen. As one of the mirrors is moved 25.8 micrometer, 92 bright fringes are counted on the screen. What is the wavelength of light used in the interferometer? **(560 nm)**
3. In section 13.4 we studied interference due to thin films. Why must the film be thin? Why don't we see the interference effect when looking through a window or at a poster covered by a plate of glass, even if the glass is optically flat.
4. Newton's rings are formed by the light of 400 nm wavelength. Determine the change in air film thickness between the third and sixth bright fringe. If the radius of curvature of the curved surface is 5.0 m what is the radius of third bright fringe? **(600, 2.236 mm)**
5. A soap film has an index of refraction $n = 1.50$. The film is viewed in reflected light.
 - (a) At a spot where the film thickness is 910.0 nm, which wavelengths are missing in the reflected light?
 - (b) Which wavelengths are strongest in the visible light?**[(a), (683 nm, 546 nm, 455 nm)] [(b), (607 nm, 496 nm, 420 nm)]**
6. What is the difference between deviation and diffraction? What do diffraction and interference have in common?
10. Is it possible to increase the orders of maxima for a given energyspectrum from a diffraction grating?
11. Describe what happens to a single slit diffraction pattern as the width of the slit is slowly decreased.
12. The diffraction pattern from a single slit of width 0.020 mm is viewed on a screen. If the screen is 1.20 m from the slit and light of wavelength 430 nm is used. What is the width of the central maximum? **(5.16 cm)**
13. A grating has exactly 8000 lines uniformly spaced over 2.54 cm and is illuminated by light from a mercury vapor discharge lamp. What is the expected angle for the third order maximum of the light of wavelength 546 nm. **($31^{\circ}3'29''$)**

14. How many lines per centimeter are there in a grating which gives 1st order spectra at an angle of 30° when the wavelength of light is 6×10^{-5} cm? (No. of lines / cm = 8333)
15. Light of wavelength 450 nm is incident on a diffraction grating on which 5000 lines/cm have been ruled. Determine
- How many orders of spectra can be observed on either side of spectra?
 - Determine the angle corresponding to each order.
- (i) = 4, (ii) = 13°, 26.7°, 42.5°, 64.2°
16. Why does a crystal act as a three dimensional grating for X-rays but not for visible light?
17. A beam of X-rays of wavelength 0.071 nm is diffracted by a diffracting plane of rock salt with distance between the atomic planes are 1.98 Å Find the glancing angle for the second-order diffraction. (21°)

Unit

14

Communication

Teaching Periods 6

Weightage % 4



Communication has wide impact in all fields. It has brought visible effect in our lives and has made our lives more comfortable. The common examples of modern communications are satellites, microwave systems, fiber optics, cellular phones, internet,

In this unit student should be able to:

- Describe how the information may be carried by number of different channels, including wire-pairs, coaxial cables, radio and microwave links, optic fibers and Satellites.
- Describe relative merits of channels of communication.
- Describe that information can be transmitted by radio waves.
- Understand the term modulation and be able to distinguish between amplitude modulation and frequency modulation.
- Define the term Bandwidth.
- Demonstrate an awareness of relative advantages of AM and FM transmission.
- Understand the advantages of transmission of data in digital form, compared with the transmission of data in analog form.
- Understand that the digital transmission of speech or music involves analog to digital (ADC) before transmission and digital to analog conversion after reception.

Communication can be defined as the exchange of information between two or more bodies. In today's world, exchange of information is not only between people, but also information exchange also takes place between machines or systems. For instance Data services like Social Media – Direct Message (DM), Instant Message (IM), SMS Text Messaging, Email Marketing, Blogging, Voice Calling, Video Chat and web browsing are some of the examples of communication.

14.1 Communication Channels:

The communication channel is the medium chosen by the sender (transmitter) for the transmission of the signal to the receiver.

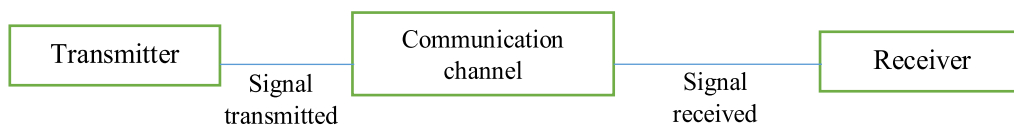

In any communication system, channels are the vital part. They may be used on land, sea or even in space. The Communication channel can be broadly classified into two categories- Cable and Broadcast. These categories are further divided into its following main components.

Cable:

- ___ Twisted Pair Cable
- ___ Coaxial Pair Cable
- ___ Optical Fibre Cable

Broadcast:

- ___ Radio or Infrared link
- ___ Microwave link
- ___ Satellite



Fig: 14.1

Telephone, telegraph, and power lines over the streets of New York City during the Great Blizzard of 1888.

14.1.1 Information Carried By Different Channels:

Twisted-Pair Cable:

Twisted -pair cable was invented by Alexander Graham Bell in 1881. It becomes widely used for telephone communication and as well as in Ethernet (joining two computers) networks. Two conducting wires are twisted forming a circuit that can transmit data and to prevent various signal interference.

There are two types of Twisted-pair cable:

Shielded Twisted -pair cable (STP) and Unshielded Twisted-pairs cable (UTP). STP is used to provide protection against crosstalk, noise and electromagnetic interference. However, UTP is used in Ethernet Installation



Fig: 14.2
Unshielded Twisted-Pair Cable



Fig: 14.3
Shielded Twisted-Pair Cable

Coaxial Cable:

The concept of Coaxial cable was given by an English Physicist and Mathematician Oliver Hearside in 1880. It consists of a copper core surrounded by an inner dielectric insulator which is then surrounded by woven copper shield. Covering this shield is the insulating jacket. In this way it has two insulating and two conducting materials act simultaneously.



Coaxial Cable was first used in 1858 but its theory was not described and in 1990 Oliver Hearside patented the design of Coaxial Cable and was accepted by the scientific community.



Fig: 14.4 Coaxial Cable

Optical Fiber:

Fiber optics sends information coded in a beam of light down a glass or plastic pipe. It works on the principle of total internal reflection. A fiber-optic cable is made up of incredibly thin strands of glass or plastic known as optical fibers; one cable can have as few as two strands or as many as several hundred. Each strand is



Fig: 14.5 Optical Fiber

less than a tenth as thick as a human hair and can carry something like 25,000 telephone calls, so an entire fiber-optic cable can easily carry several million calls. The optical fibre consists of fibre core wrapped by cladding, coating, buffer, strength members and finally surrounded by outer insulating jacket as shown in figure.14.5

Radio Waves:

Radio waves as already discussed in chapter 13, are the lowest-energy, lowest-frequency and longest-wavelength electromagnetic waves. In communication of radio wave, the emission of electromagnetic waves takes place by the transmitter antenna at one place and reached the receiving antenna at the other place after travelling through the space.

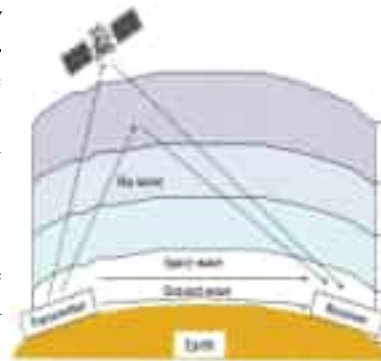

Fig: 14.6 Modes of radio waves propagation

Propagation of Radio Waves:

The three modes for radio waves propagation are:

- 1. Ground Wave or Surface Wave Propagation:** The radio waves propagate over the earth's surface from transmitting antenna to receiving antenna in low and medium frequencies up to 2 MHz are called Ground waves. These are used for local broadcasting.
- 2. Sky Wave Propagation:** Sky Wave propagation, also called ionospheric propagation, It is either the reflected or refracted to the earth from the ionosphere. It is suitable for frequency between 2 MHz to 30 MHz and used for long distance radio communication.
- 3. Space Wave Propagation:** These waves are suitable for 30 MHz to 300 MHz and used in television communication and radar communication. It is also called line of sight communication as these waves travel straight from transmitting antenna to receiving antenna.

Microwaves:

Electromagnetic waves having frequency range from 1 to 300 GHz are known as microwaves. They can be used to transmit signals over large distances through the space without the use of cable. As microwave signals cannot pass obstacles like hill, the transmitter and receiver should be in a line of sight. Microwaves are broadly used for point-to-point communications as their small wavelength permits suitably-sized antennas to direct them in narrow beams, which can be pointed directly at the receiving antenna. In radar, microwave communication is used to locate the flying objects in space.

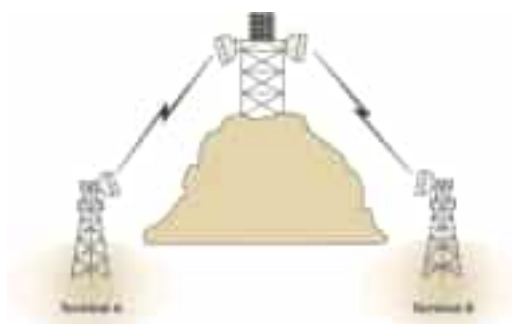

Fig: 14.7 A Microwave Link

Satellite Communication:

Satellites are used for larger distance communication which revolves around the earth in elliptical orbits. Watching the Cricket match of a world cup from anywhere in the world friends would have been impossible without this. A communication satellite is an artificial satellite that transmits the signal via a transponder by creating a Channel between the transmitter and the receiver located at different locations on the Earth. They have a wide range of applications like radio, navigation, military, atmospheric conditions, crop monitoring, etc. Hence, satellites have become an integral part of our daily life.



Fig: 14.8 Satellite Communication

14.1.2 Merits of Channel of Communication:

Twisted Wire Pair: Easy to implement and low cost for short distances. Breakage in a segment doesn't affect the whole network. Less vulnerable to interference.

Coaxial Cable: Suitable for analog and digital data transmission, higher bandwidth, and cost-effective compared to fiber optic cables.

Optical Fiber: High bandwidth and speed, cost-effective for long distances, and minimal signal loss compared to copper wires.

Microwave Radio Systems: Transmit large data volumes over long distances without physical cables, using repeaters. Lower construction costs than other transmission methods.

Satellite Communication is versatile and location-independent, providing mobile and wireless communication. A single satellite can cover wide areas, entire countries, or regions. It is easy to install and manage ground stations. Used for audio, data, video, internet, and GPS applications, it has various uses like forecasting, broadcasting, military intelligence, navigation, global mobile communication, and connecting remote areas..

DO YOU KNOW?

Three geostationary satellites, each separated by 120 degrees of longitude, can provide coverage of the entire earth.

Self-Assessment Questions:

1. What are the major parts of a communication system?
2. What is the purpose of a transducer at the transmitting end?
3. Which communication channel is best for mobile and other wireless communication applications?

14.2. Modulation:

Modulation is the process of transmitting a message signal with a carrier signal to cover longer distances while maintaining message quality. It uses high-frequency carrier waves for energy and overcoming obstructions during transmission. Antennas translate audio signals to higher frequencies for effective operation. Modulation varies the carrier wave's characteristic with time. Both analog and digital information can be encoded using modulation, enabling efficient communication systems like cell phones that convert voice into electrical signals for transmission and reception. Mathematically, a carrier wave is represented by a sinusoidal waveform

$$V_c(t) = A \sin(2\pi f_c t + \phi) \dots\dots\dots 14.1$$

Where

- A – represents the amplitude of the carrier wave
- f_c – represents the frequency of the carrier wave
- ϕ – represents the phase angle

The waveform represented by Eq.14.1 is sketched in Fig: 14.9

A signal tone (i.e a tone having one frequency) modulating signal can be represented by

$$V_m(t) = B \sin 2\pi f_m t$$

Where B and f_m represents the amplitude and frequency of the modulating signal respectively.

DO YOU KNOW?

The length of the antenna should be $\lambda/4$ times of the modulating signal in order to get effective communication ($H_{min} = \lambda/4$)

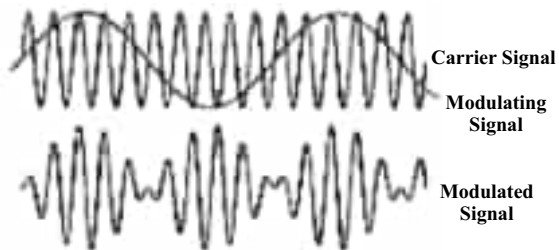

Fig: 14.9 Modulating

Types of Modulation:

A signal possesses multiple parameters like Amplitude, Frequency and Phase. In case of modulation, any of these parameters of a carrier signal are modified with respect to the message signal (baseband signal) which differentiates the types of modulation being used. The Analogue Modulation which is largely divided into two major types.

1. **Amplitude Modulation**
2. **Angle Modulation**

The Angle modulation is further divided into two main types:

1. **Frequency Modulation**
2. **Phase Modulation.**

We will only discuss Frequency Modulation as a scope of this book.

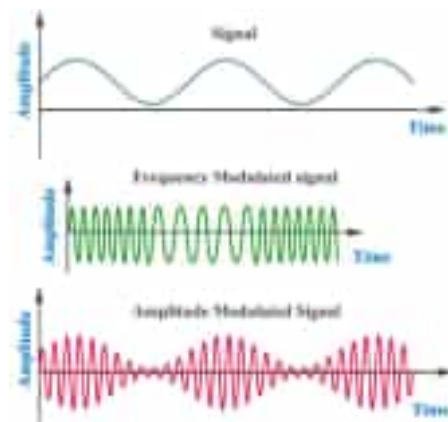

Fig: 14.10 Amplitude Modulation

Amplitude Modulation:

It is the type of modulation in which the amplitude of the carrier signal is varied in proportion to the message signal whereas the frequency and phase of the carrier are constant. Television Broadcast is an example of AM.

Expression for Amplitude Modulated Wave:

We have carrier wave and modulating signal,
 $m(t) = A_m \sin \omega_m t$ and $c(t) = A_c \sin \omega_c t$ 1
 $m(t)$ = modulating signal and $c(t)$ = carrier wave.

A_m and A_c are Amplitude of modulating signal and carrier wave respectively in Amplitude modulation. Amplitude-modulated wave $C_m(t)$ will be
 $C_m(t) = (A_c + A_m \sin \omega_m t) \sin \omega_c t$ 2

This is the general form of amplitude modulated wave.
 Where,

$A = A_c + A_m \sin \omega_m t$ = Amplitude of the modulated wave
 $\sin \omega_c t$ = Phase of modulated wave
 $C_m(t) = A_c (1 + A_m/A_c \sin \omega_m t) \sin \omega_c t$
 $= A_c \sin \omega_c t + A_m/A_c A_c \sin \omega_m t \sin \omega_c t$

Where,
 $A_m/A_c = \mu$ = modulation index
 $C_m(t) = A_c \sin \omega_c t + A_c \mu \sin \omega_m t \sin \omega_c t$

Frequency Modulation:

It is the type of modulation in which the frequency of the carrier signal varies in proportion to the message signal and the amplitude of a carrier wave remains constant. Cellular communication is an example of FM.

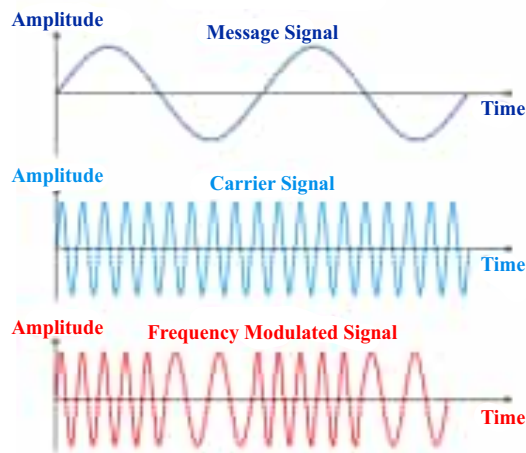

Fig: 14.11 Frequency Modulation

Expression for Frequency Modulated Wave:

As we know from amplitude modulation, we need two sine (or) cosine waves for modulation.

$m(t) = A_m \cos (\omega_m t)$ and $c(t) = A_c \cos (\omega_c t)$ 1
 or

$m(t) = A_m \cos (2\pi f_m t)$ and $c(t) = A_c \cos (2\pi f_c t)$
 Then frequency modulated wave will be;
 $f_m(t) = f_c + k A_m \cos (2\pi f_m t)$ 2

$f_m(t) = f_c + k m(t)$
 Where,
 $f_m(t)$ = is frequency modulated wave
 f_c → frequency of the carrier wave
 $m(t)$ → modulating signal and k → proportionality constant.

DO YOU KNOW?

Modulation Index signifies the level of distortion or noise. A lower value of modulation index indicates a lower distortion in the transmitted signal.

Advantages of AM (Amplitude Modulation):

1. Simplicity: AM modulation is relatively simple to implement, making it cost-effective and widely used in broadcasting.
2. Efficient use of bandwidth: AM occupies a narrower bandwidth compared to FM, making it suitable for long-range communication and more efficient use of available frequencies.
3. Compatibility: AM receivers can pick up weak signals, making it suitable for reception in areas with weaker signals or during atmospheric disturbances.
4. Immunity to sudden interference: AM signals are less affected by sudden noise or interference, allowing for clearer reception during temporary disturbances.

Advantages of FM (Frequency Modulation):

1. Better sound quality: FM provides better sound quality compared to AM, making it ideal for broadcasting music and high-fidelity audio.
2. Noise immunity: FM is less susceptible to noise and static interference, resulting in clearer and more consistent reception.
3. Wider frequency range: FM has a wider frequency range, allowing for more channels and better transmission of stereo signals.
4. Higher signal-to-noise ratio: FM provides a higher signal-to-noise ratio, enhancing the overall signal quality and reducing the impact of background noise.

In summary, AM is advantageous for simplicity, cost-effectiveness, and long-range communication, while FM offers superior sound quality, noise immunity, and a wider frequency range, making it suitable for broadcasting high-quality audio and music. The choice between AM and FM depends on the specific requirements and objectives of the communication system or broadcasting application.

14.2.3 Bandwidth:

The bandwidth is closely linked to the capacity at which network transmit data or information. It is the total range of frequency required to pass a specific signal that has been modulated to carry data without distortion or loss of data. If ν_1 and ν_2 are the lower and upper-frequency limits of a signal, then the bandwidth, $BW = \nu_2 - \nu_1$.

In communication system, the message signal can be voice, music, and picture or computer data. All of these have different ranges of frequencies. For example, for speech signals frequency range is from 300 Hz to 3100 Hz. Similarly, for music signal transmission approximately a bandwidth of 20 KHz is required.

Relative Advantages of AM and FM Transmissions:

Amplitude modulation is simple, economical and easily obtainable (circuit with fewer components). As it doesn't require any specialized components, the receivers of AM are inexpensive. AM waves can travel a long distances and have low bandwidth. However, in FM receivers the noise can be reduced by increasing the frequency deviation and hence FM reception is immune to noise as compared to AM reception. In AM transmission most of the power has been wasted in the transmitted carrier. Whereas, FM transmitters are highly efficient and their power wastage is very low. FM can be implemented at low power stages of

a transmitter so a two-way radio application system is feasible for FM. Due to a large number of side bands, FM can be used for the stereo sound transmission.

Distinguish between AM and FM:

Frequency Modulation (FM) and Amplitude Modulation (AM) are two distinct methods of modulating electromagnetic waves for radio communication. AM varies the carrier wave's amplitude in proportion to the modulating signal, while FM changes the carrier wave's frequency based on the signal variations. FM signals have constant amplitude but varying frequency, offering better audio quality and resistance to noise. However, they require a wider bandwidth. AM signals have constant frequency but varying amplitude, making them more susceptible to noise, yet they require a narrower bandwidth. FM is preferred for high-fidelity broadcasting, while AM is used for long-range transmission and amplitude-sensitive applications.

Self-Assessment Questions:

1. Write two factors which justify the need of modulating a low frequency signal into high frequencies before transmission.
2. What type of modulation is employed in Pakistan for radio transmission?

14.3 Digital Communication System:

In a Digital Communication System, generally the messages generated by the source are in analog form. They are converted to digital format before transmission. At the receiver end, the received digital data is converted back to analog form, which is an approximation of the original message.

A digital communication system consists of six basic blocks. The functional blocks at the transmitter are responsible for processing the input message, encoding, modulating, and transmitting over the communication channel. The functional blocks at the receiver perform the reverse process to retrieve the original message.

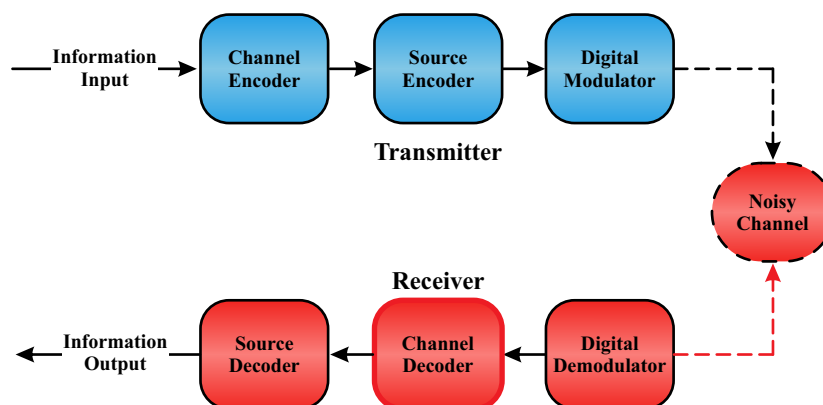

Fig: 14.13
Block Diagram of a Digital Communication System

14.3.1 Advantages of the Transmission of Data in Digital Form Over Transmission in Analog Form:

There are many differences between analog and digital transmission, and digital transmission has many clear advantages over traditional analog transmission. Let's look first at the older form of transmission, analog. In analog transmission we convey data, signal, image, video information, and voice through a continuous signal. However, in digital transmission, the transfer of information and data takes place by using digital signals (a series of discrete pulses, representing one bits and zero bits) over a wired and wireless medium.

The main advantages of digital transmission that made it much superior to its analog counterpart are given below:

1. **Performance:** Analog signals suffer from distortion and noise, even if they are small. In digital signal transmission can be made perfect due to less noise and distortion.
2. **Compression and Security:** Source and error control codes provide maximum accuracy, fidelity, compression and security to digital transmission that cannot be attained with analog signals. Digital signals can be saved and recovered more easily than analog signals.
3. **Multiplexing:** Multiplexing of several different digital signals can be done easily. For example, combining digital signals using Time Division Multiplexing (TDM) is much easier than combining analog signals using Frequency Division Multiplexing (FDM).
4. **Storage:** In analog signal storage quality cannot be sustained over time. Whereas, Digital signals can be stored and retrieved more accurately and inexpensively by the use of transistors and error control codes.
5. **Signal Processing:** Signal Processing of Digital signals can be achieved in a simple and flexible way by using different program updates. Furthermore, we can change protocols and algorithms as per our requirement. This provides much more flexibility as compared to analog signal processing.
6. **Reconstruction:** Digital signals can be faultlessly carried over larger distances by using repeaters. However, analog signals have become gradually weaker along the channel due to severe noise and distortion. This behavior limits the range of transmission of analog signals governed by the input power.
7. **Cost:** Digital communication systems depend on computing devices like processors and very large-scale integrated (VLSI) circuits that increasingly benefit from Moore's law: the number of transistors in an integrated circuit (IC) has been increased rapidly and almost doubled about every two years. This lead to cost and performance advantages over a long period of time.

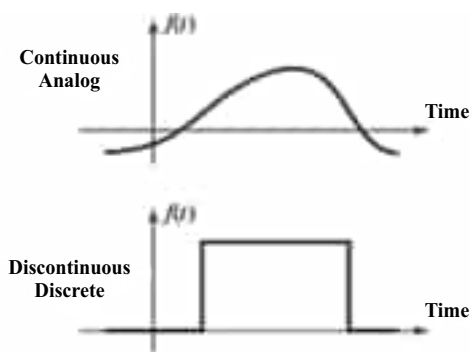

Fig: 14.14 Analog and Discrete Signals

- 8. **Secrecy:** Cross-talk is rarely happening in digital communication due to encryption and compression of data in digital transmission to maintain the secrecy of the information.
- 9. **Quality of Copies:** Quality of copies in analog transmission is not good as compared to its original while due to error free digital transmission, copies can be made definitely.

Digital transmission of speech or music:

If nature produces analog signals, how do we create digital signals from them? Before we start digital transmission, we must convert the signal of interest into a digital format. The natural signal (e.g., speech) or music that we want to transmit will be acquired using an analog device. The analog signal will be translated into a digital signal using a method called analog-to-digital (A/D) conversion. The device used to perform this translation is known as an analog-to-digital converter (ADC). This process is depicted in Fig 14.15.

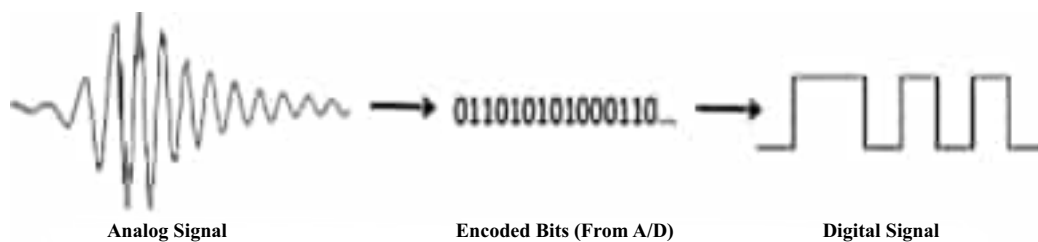

Fig: 14.15 A to D Conversion

Steps for A/D conversion:

There are three processes involved in conversion of Analog to Digital signals:

1. Sampling:

This is a process of inspecting the value (voltage) of an analog signal at regular time intervals. The time between samples is referred to as the sample period (T, in seconds), and the number of samples taken per second is referred to as the sample frequency (fs, in samples/second or Hz).

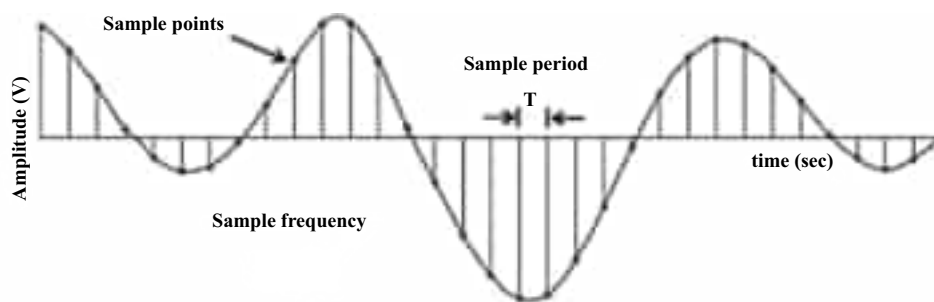

Fig: 14.16 Sampling Waveform

The receiver must convert the bits it receives into sample values, and then recreate what it thinks the analog signal looks like from the samples. One must sample faster than the Nyquist sampling rate (also called the Nyquist rate), f_N , given by the formula $f_N = 2f_{max}$, where f_{max} is the highest frequency component of the analog signal. To avoid distortion of your signal $F_s > f_N$. Some examples of common sample rates are given in the table 14.1.

Common Sample rates Table 14.1

Signal	Signal frequency range	Standard Sample Rate
Voice	300 Hz-3 kHz	8KHz
Music	0-20 kHz	44.1 kHz CD Quality
Music	0-20 kHz	192 kHz DVD Quality

2. Quantizing:

Quantizing is the process of mapping the sampled analog voltage values to discrete voltage levels, which are then represented by binary numbers (bits). For example, if a sine wave of amplitude 1V is being sampled, the sample values could be between -1V and +1V... an infinite number of possibilities. However, only a finite number of values can be used to represent the samples. Converting a sample value from infinite possibilities to one of a finite set of values is called quantization. These values are referred to as quantization levels.

DO YOU KNOW?

Digital telephony uses 8-bit A/D quantizing ($2^8 = 256$ quantization levels) and CD audio, which uses 16-bit A/D ($2^{16} = 65,536$ quantization levels).

An N-bit A/D converter has 2^N quantization levels and outputs binary words of length N. For example, a 3-bit A/D system has $2^3 = 8$ quantization levels, so all samples of a 1V analog signal will be quantized into one of only 8 possible quantization levels and each sample will be represented by a 3-bit digital word. In general, the A/D converter will partition a range of voltage from some V_{min} to some V_{max} into 2^N voltage intervals, each of size q volts, where

$$q = \frac{V_{max} - V_{min}}{2^N}$$

3. Encoding:

After quantization the samples are converted to N-bit binary code words. For the first sample point at time 0, the voltage is 0.613 V, which means that sample is assigned a binary value of 110.

The A/D then creates a voltage signal that represents these bits. The binary representation of the above signal is:

110 101 100 011 011 100 110 110 100 010 000 000 001.

In this example, every sample produces 3 bits (3 bits/sample). The sample rate was 2000 samples/sec. The bit rate (R_b) produced from this:

$$R_b = \frac{3 \text{ bits}}{\text{sample}} \times \frac{2000 \text{ samples}}{\text{sec}} = 6000 \text{ bits/sec (bps)}$$

Bit rate is the speed of transfer of data given in number of bits per second.

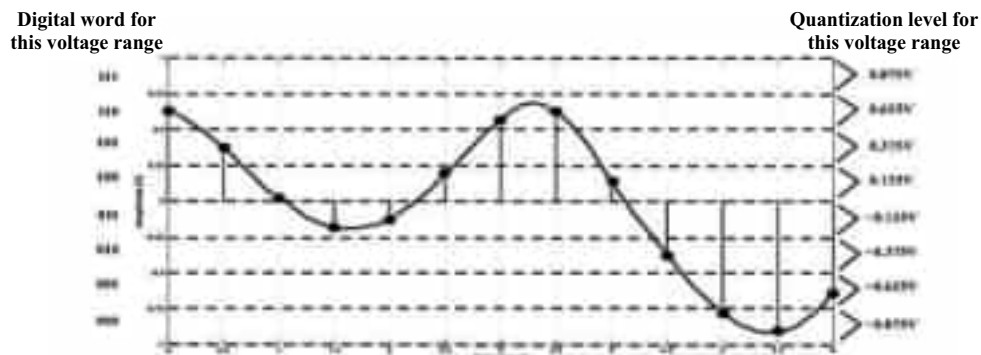

Fig. 14.17 Coding Waveform

Conversion from Digital to Analog (D/A):

The receiver converts these N-bit digital words back into an analog signal. This process is called digital-to-analog (D/A) conversion. The analog signal is reconstructed by converting the N-bit digital words into the appropriate quantization levels, and this voltage is “held” for one sample period, creating a stair-step type signal shown below.

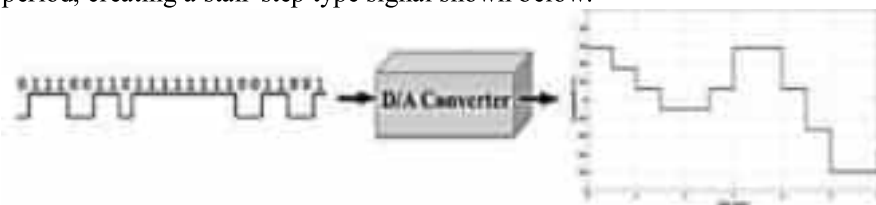

Fig. 14.18 D to A Conversion

The reconstructed analog signal for is shown in a thick black line in the figure 14.19, along with the 3bit digital word that represents each sample. The original analog signal is also shown in the continuous line. Even if we perform filtering to smooth out the reconstructed signal to remove its staircase appearance it will still not quite be the same as the original red signal. It is called quantization error.

Quantization error can be reduced by increasing the number of bits N for each sample. This will make the quantization intervals smaller.

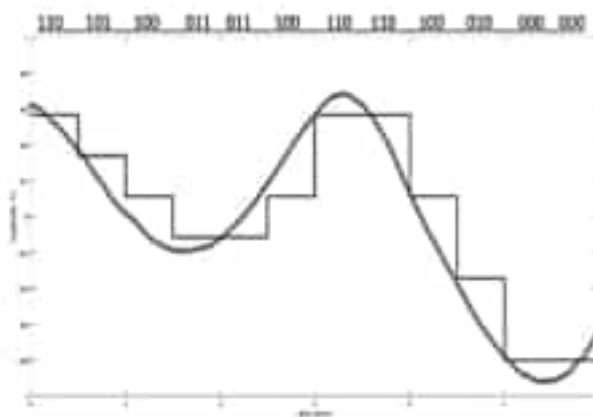
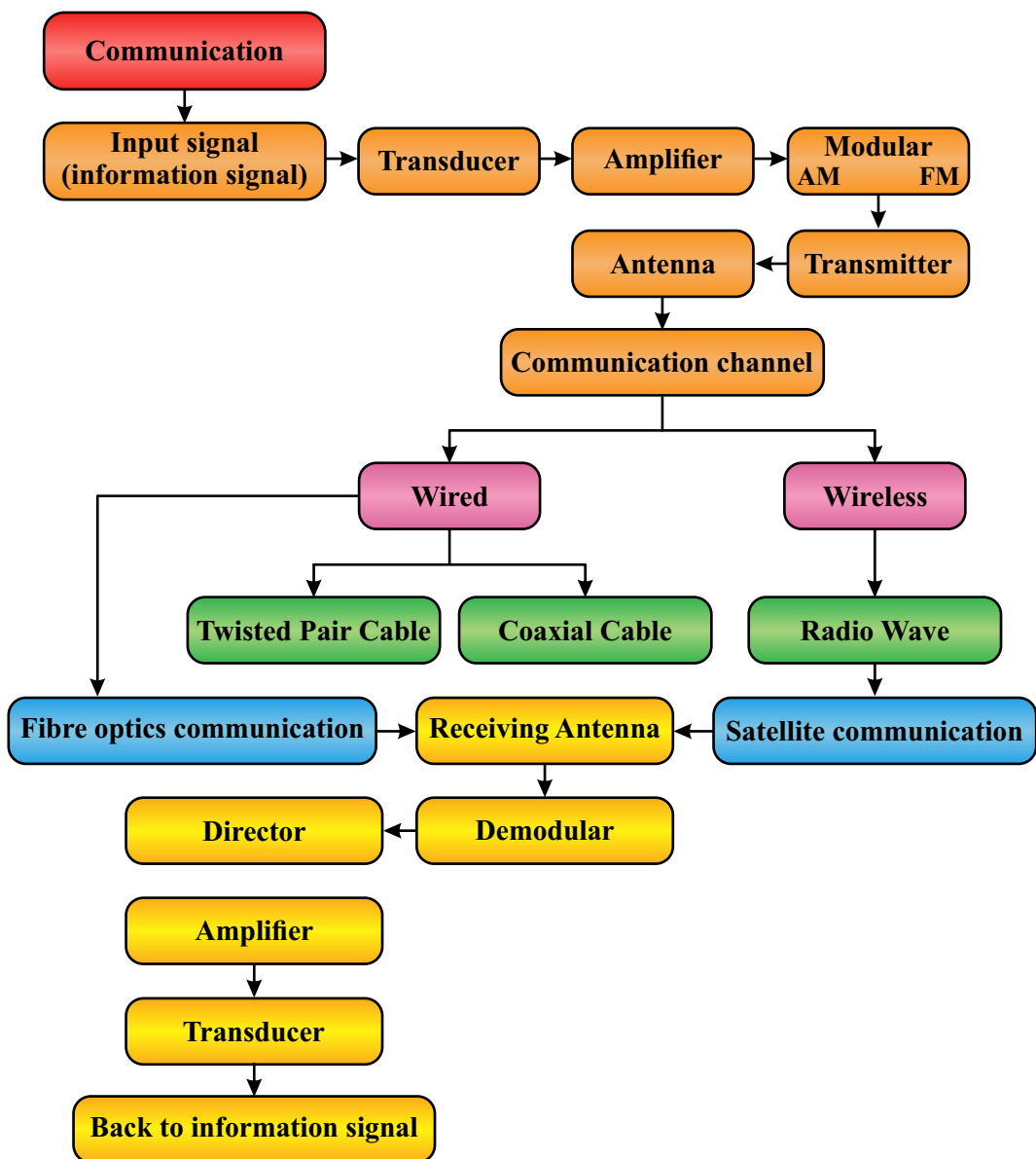

Fig. 14.19 Reconstruction of Analog Signal



SUMMARY

- Communication can be defined as the exchange of information between two or more bodies.
- There are two types of data, analog data or signal is continuous and digital data which has discrete values. For transmission of information analog or digital a transmission system consists of three parts
 - (i) transmission equipment
 - (ii) communication medium or channel providing the physical link between sender and receiver and
 - (iii) receiving equipment.
- A communication channel refers either to a physical transmission medium such as a wire, or to a logical connection over a multiplexed medium such as a radio channel in telecommunications.
- There are different types of channels used for transmission a thin-diameter wire (22 to 26 gauges) commonly used for telephone and network cabling.
- Coaxial cable supports 10 to 100 Mbps and is relatively inexpensive, although it is costlier than UTP on a per-unit length.
- Optical fiber refers to the medium and the technology associated with the transmission of information as light pulses along a glass or plastic strand or fiber..
- Satellite is also a source of sending information. Satellite communications, use the very high-frequency range of 1–50 gigahertz.
- The process of imposing an input signal onto a carrier wave is called modulation. There are two types of modulation Amplitude modulation and Frequency modulation.
- Bandwidth is the total range of frequency required to pass a specific signal that has been modulated to carry data without distortion or loss of data.
- Digital transmission is the transfer of information and data using digital signals over a wired and wireless medium. In a Digital Communication System, the messages generated by the source which are generally in analog form are converted to digital format and then transmitted.
- The natural signal (e.g., speech) or music that we want to transmit will be acquired using an analog device.
- The analog signal will be translated into a digital signal using a method called analog-to-digital (A/D) conversion.
- There are three processes involved in conversion of Analog to Digital signals
 - 1. Sampling
 - 2. Quantizing
 - 3. Encoding
- We recover the analog information after it has been converted to digital by Digital to analog conversion (D/A). It is very similar to being the reverse of the analog-to-digital conversion process. The analog signal is reconstructed by converting the N-bit digital words into the appropriate quantization levels.





EXERCISE

Section (A): Multiple Choice Questions (MCQs)

- In Radio and Television broadcast, the information signal is in the form of:
 - analog signal
 - digital signal
 - Both analog & digital signals
 - neither analog nor digital signal
- A communication channel consists of:
 - transmission line only
 - optical fibre only
 - free space only
 - All of them
- Voltage signal generated by a microphone is:
 - digital in nature
 - analog in nature
 - hybrid in nature
 - consists of bits & bytes
- As compared to sound waves frequency of radio waves is:
 - higher
 - equal
 - lower
 - may be higher or lower
- The process of superimposing signal frequency on the carrier wave is known as:
 - transmission
 - detection
 - reception
 - modulation
- What is the frequency range of signals that can be transmitted in case of twisted pair of wires?
 - 10MHz. to 15MHz.
 - 5MHz. to 10MHz.
 - 100Hz. to 5MHz.
 - 10Hz. to 100Hz.
- The maintenance of a satellite's orbital position is called:
 - maintenance keeping
 - station keeping
 - station maintenance
 - attitude control
- Process of mapping the sampled analog voltage values to discrete voltage levels is called:
 - sampling
 - sampling frequency
 - quantizing
 - encoding
- AM is used for broadcasting because:
 - it requires less transmitting power compare with other systems
 - it is more noise immune than other modulation system
 - No other modulation can provide the necessary bandwidth faithful transmission
 - its use avoids receiver complexity
- Data in compact disc is stored in the form of :
 - analog signal
 - digital signal
 - noise
 - both (a) &(b)

Section (B): Structured Questions

CRQs:

1. A male voice after modulation-transmission sounds like that of a female to the receiver. Give reason.
2. Why is an AM signal likely to be more noisy than a FM signal upon transmission through a channel?
3. Write 5 differences between analog and digital transmission.
4. Define core and cladding. On what principle does optical fibre work?
5. What is a Digital Communication System? Why it is advantageous to use digital communication over analog communication.
6. Give 5 advantages of satellite communication.
7. Write advantages and disadvantages of frequency modulation.
8. What are limitations of amplitude modulation?

ERQs:

1. What is modulation? Why it is needed for the transmission of signals?
2. How many types of modulation are there? Explain each type of modulation in detail.
3. What is A/D conversion? Explain sampling, quantizing and encoding involved in A/D conversion in detail.
4. Define communication channel. How information carried through UTP, STP and Coaxial cable? Write their advantages and disadvantages.
5. What is optical Fibre? How information carried out through optical fibre? Give advantages of using optical fibre over other communication channels.
6. What are the main components of a Satellite? How communication takes place in a satellite. Explain three orbits of a satellite.